

Technical Deep Dive: Exploring Zinc Dynamics in Live Cells with ZnAF-1

Author: BenchChem Technical Support Team. **Date:** May 2026

Compound of Interest

Compound Name: ZnAF-1, 5-Iso

Cat. No.: B11928710

[Get Quote](#)

Executive Summary

Zinc (Zn^{2+}) acts as a pivotal "ionic signal" in cellular physiology, influencing synaptic plasticity, gene expression, and apoptosis. Unlike calcium, which has a robust toolbox of indicators, labile zinc pools are smaller and more transient, requiring probes with exceptional sensitivity and selectivity.

ZnAF-1 (Zinc-Amino-Fluorescein 1) represents a foundational tool in this domain. It is a high-affinity, fluorescein-based sensor designed to visualize nanomolar concentrations of labile Zn^{2+} . [1] This guide provides a rigorous technical framework for deploying ZnAF-1 in live-cell imaging, moving beyond basic protocols to address the mechanistic "why" and the experimental "how" required for high-fidelity data.

Chemical Architecture & Mechanism of Action

The PET Quenching Mechanism

ZnAF-1 operates on the principle of Photoinduced Electron Transfer (PET). Understanding this mechanism is crucial for interpreting signal-to-noise ratios and potential artifacts.

- The Fluorophore: A fluorescein backbone provides the optical engine (Excitation: ~492 nm, Emission: ~515 nm).
- The Receptor: An electron-rich receptor, typically an N,N-bis(2-pyridylmethyl)ethylenediamine (TPEN-like) derivative, is covalently attached to the benzoic acid moiety of the fluorescein.
- The Switch:
 - Apo State (No Zn^{2+}): The lone pair electrons on the receptor's nitrogen atoms transfer to the excited fluorophore, quenching fluorescence (non-radiative decay).
 - Bound State (+ Zn^{2+}): Zinc binding engages these lone pairs, lowering the energy level of the receptor's HOMO (Highest Occupied Molecular Orbital) below that of the fluorophore. This blocks the PET process, restoring strong fluorescence.

Key Physicochemical Properties

Property	Value	Implication for Experimental Design
Dissociation Constant ()	~2.2 nM	Ideal for detecting resting labile Zn^{2+} (picomolar to low nanomolar range).
Excitation / Emission	492 nm / 515 nm	Compatible with standard GFP/FITC filter sets; no specialized optics required.
Selectivity	High (vs. Ca^{2+} , Mg^{2+})	Minimal interference from millimolar physiological cations.
pH Sensitivity	pKa ~ 6.2	Critical Limitation: Fluorescence decreases in acidic environments (pH < 7.0).[2] Use caution in lysosomes or ischemic models.

Mechanism Visualization

The following diagram illustrates the PET-based "off-on" switch that governs ZnAF-1 functionality.

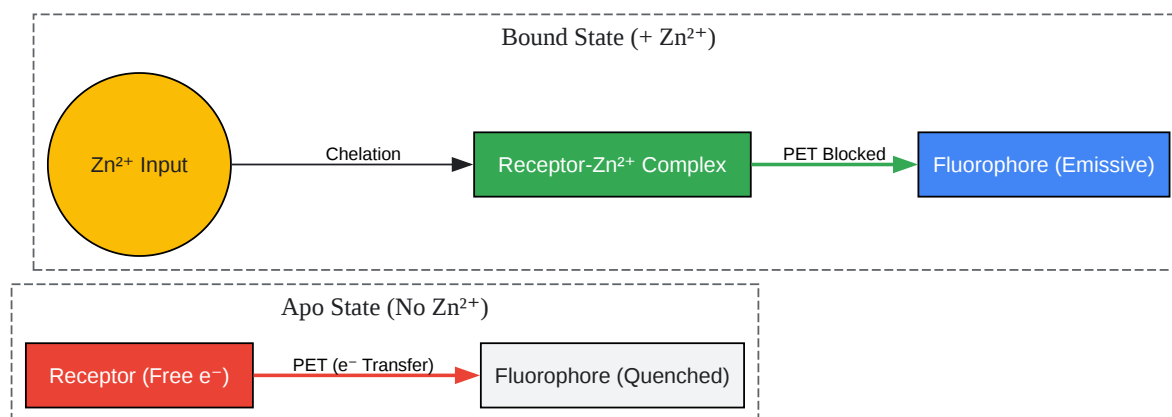

[Click to download full resolution via product page](#)

Figure 1: Mechanism of ZnAF-1 fluorescence activation via inhibition of Photoinduced Electron Transfer (PET).

Experimental Workflow: Live Cell Imaging

For live-cell applications, the acetoxymethyl or diacetate ester form (ZnAF-1 DA) is required to cross the plasma membrane. Once inside, intracellular esterases cleave the acetyl groups, trapping the anionic, active probe within the cytosol.[3]

Reagent Preparation

- Stock Solution: Dissolve ZnAF-1 DA in high-quality anhydrous DMSO to a concentration of 1–5 mM.
 - Storage: Aliquot into small volumes (e.g., 10 μ L) and store at -20°C, protected from light. Avoid repeated freeze-thaw cycles to prevent hydrolysis.

- Loading Buffer: Use a physiological buffer (e.g., HBSS or Krebs-Ringer) containing $\text{Ca}^{2+}/\text{Mg}^{2+}$ but strictly free of serum.
 - Why? Serum proteins (albumin) bind zinc and the probe, reducing loading efficiency and increasing background.

Optimized Staining Protocol

This protocol is self-validating, ensuring that the signal observed is intracellular and responsive.

Step 1: Cell Preparation

- Culture cells to 60–80% confluency on glass-bottom dishes (for confocal) or coverslips.
- Wash cells 2x with warm Loading Buffer to remove serum-containing media.

Step 2: Dye Loading

- Dilute ZnAF-1 DA stock into Loading Buffer to a final concentration of 1–5 μM .
- Optional: Add Pluronic F-127 (0.02%) to aid solubility if "punctate" background staining is observed.
- Incubate for 30 minutes at 37°C in a humidified CO_2 incubator.

Step 3: Post-Loading Recovery (The "De-esterification" Step)

- Aspirate the loading solution.
- Wash cells 2x with fresh Loading Buffer.
- Incubate in fresh buffer for an additional 15–20 minutes at 37°C.
- Expert Insight: This step is crucial. It allows time for intracellular esterases to fully cleave the DA groups and for any uncleaved/leaked probe to be washed away, improving the signal-to-noise ratio.

Step 4: Imaging

- Transfer to the microscope stage (maintain 37°C if possible).
- Excitation: 488 nm laser or FITC filter excitation.
- Emission: 500–550 nm bandpass filter.
- Acquisition: Minimize laser power to <1% to prevent photobleaching and phototoxicity, which can cause cell leakage.

Experimental Workflow Diagram

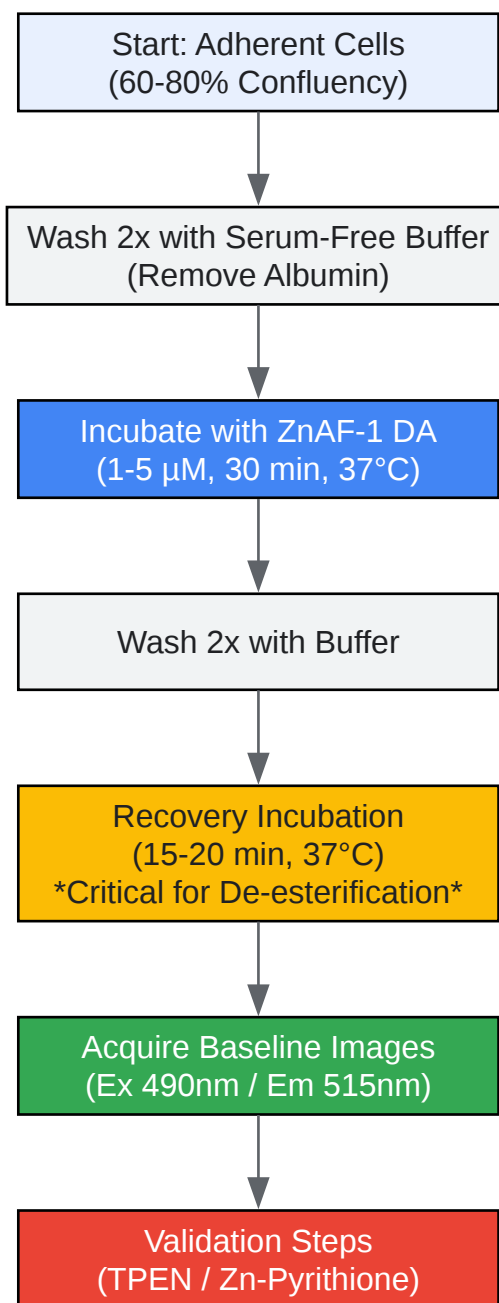

[Click to download full resolution via product page](#)

Figure 2: Optimized workflow for live-cell zinc imaging with ZnAF-1 DA.

Data Analysis & Interpretation

ZnAF-1 is an intensity-based probe, not a ratiometric one. This means signal intensity correlates with Zn^{2+} concentration, but it is also influenced by probe concentration and cell thickness.

Quantifying Zinc Dynamics

To normalize for variations in probe loading, data is best presented as relative fluorescence change (

):

Where:

- is the fluorescence intensity at time .
- is the mean intensity of the region of interest (ROI) before stimulation.

Background Correction

Always select a cell-free background region in the image and subtract its mean intensity from your cellular ROIs before calculating

Critical Validation & Troubleshooting

Trustworthiness in zinc imaging comes from proving the signal is truly Zn^{2+} -dependent. Every experiment must include the following internal controls.

The "Min/Max" Validation Protocol

After acquiring your experimental data, perform these sequential additions on the same field of view:

- Maximum Signal (): Add Zn-Pyrithione (10–20 μ M) or Zn-pyrithione/ZnCl₂ (1:1).
 - Action: Pyrithione is an ionophore that shuttles extracellular Zn^{2+} into the cell.
 - Result: You should see a rapid, saturating increase in fluorescence. This confirms the probe is present and functional.

- Minimum Signal (): Add TPEN (50 μ M).
 - Action: TPEN is a membrane-permeable, high-affinity intracellular zinc chelator (< M).
 - Result: Fluorescence should drop below baseline. This confirms the baseline signal was due to labile Zn^{2+} and not autofluorescence or other ions.

Common Pitfalls

- Signal Decay (Bleaching): If the baseline drifts downward, reduce exposure time or acquisition frequency.
- Lack of Response: If Zn-Pyrithione fails to increase signal, the probe may have leaked out (check washing steps) or hydrolyzed poorly (check stock quality).
- pH Artifacts: Remember ZnAF-1 is pH-sensitive. If your experimental treatment causes intracellular acidification (e.g., ischemia), the fluorescence drop may be due to pH, not zinc. In such cases, consider using ZnAF-2F, which has a lower pKa (~4.9) and is stable at pH 6–7.

References

- Hirano, T., Kikuchi, K., Urano, Y., Higuchi, T., & Nagano, T. (2000). Highly Zinc-Selective Fluorescent Sensor Molecules Suitable for Biological Applications. *Journal of the American Chemical Society*, 122(48), 12399–12400.
- Hirano, T., Kikuchi, K., Urano, Y., & Nagano, T. (2002). Improvement and Biological Applications of Fluorescent Probes for Zinc, ZnAFs. *Journal of the American Chemical Society*, 124(23), 6555–6562.
- Domaille, D. W., Que, E. L., & Chang, C. J. (2010). Synthetic fluorescent sensors for studying the cell biology of metals. *Nature Chemical Biology*, 6(3), 162–170.

- Carter, K. P., Young, A. M., & Palmer, A. E. (2014). Fluorescent Sensors for Measuring Metal Ions in Living Systems. *Chemical Reviews*, 114(8), 4564–4601.

Need Custom Synthesis?

BenchChem offers custom synthesis for rare earth carbides and specific isotopic labeling.

Email: info@benchchem.com or [Request Quote Online](#).

Sources

- [1. adipogen.com \[adipogen.com\]](#)
- [2. researchgate.net \[researchgate.net\]](#)
- [3. ZnAF®-2/ ZnAF®-2 DA Zinc ion imaging probe | Goryo Chemical, Inc. \[goryochemical.com\]](#)
- To cite this document: BenchChem. [Technical Deep Dive: Exploring Zinc Dynamics in Live Cells with ZnAF-1]. BenchChem, [2026]. [Online PDF]. Available at: [\[https://www.benchchem.com/product/b11928710/docs#technical-deep-dive-exploring-zinc-dynamics-in-live-cells-with-znaf-1\]](https://www.benchchem.com/product/b11928710/docs#technical-deep-dive-exploring-zinc-dynamics-in-live-cells-with-znaf-1)

Disclaimer & Data Validity:

The information provided in this document is for Research Use Only (RUO) and is strictly not intended for diagnostic or therapeutic procedures. While BenchChem strives to provide accurate protocols, we make no warranties, express or implied, regarding the fitness of this product for every specific experimental setup.

Technical Support: The protocols provided are for reference purposes. Unsure if this reagent suits your experiment?

Need Industrial/Bulk Grade? [Request Custom Synthesis Quote](#)

BenchChem

Our mission is to be the trusted global source of essential and advanced chemicals, empowering scientists and researchers to drive progress in science and industry.

Contact

Address: 3281 E Guasti Rd

Ontario, CA 91761, United States

Phone: (601) 213-4426

Email: info@benchchem.com

[Contact our Ph.D. Support Team for a compatibility check](#)