

# common problems with UBP684 in long-term recordings

**Author:** BenchChem Technical Support Team. **Date:** April 2026

## Compound of Interest

Compound Name: UBP684

Cat. No.: B11927763

[Get Quote](#)

## Technical Support Center: UBP684

This technical support center provides troubleshooting guides and frequently asked questions (FAQs) for researchers, scientists, and drug development professionals using **UBP684**, a positive allosteric modulator (PAM) of N-Methyl-D-Aspartate (NMDA) receptors, in long-term recordings.

## Troubleshooting Guides

This section addresses specific issues that may be encountered during long-term experiments with **UBP684**.

Problem ID	Issue	Potential Cause	Suggested Solution
LT-001	Diminishing or variable potentiation of NMDA receptor currents over time.	pH shift in recording medium: UBP684's activity is highly pH-dependent, with greater potentiation at lower pH and inhibition at alkaline pH (e.g., 8.4)[1]. The pH of cell culture or recording medium can increase over time in a CO2 incubator or decrease due to cellular metabolism.	1. Monitor and maintain a stable physiological pH (7.2-7.4) of your recording solution throughout the experiment.2. Use a well-buffered recording solution (e.g., HEPES-buffered).3. For long-term cell culture experiments, ensure proper CO2 levels are maintained to control medium pH.
LT-002	Signs of neuronal excitotoxicity (e.g., cell swelling, dendritic beading, cell death).	Prolonged and excessive NMDA receptor activation: As a positive allosteric modulator, UBP684 enhances NMDA receptor function, which can lead to excessive calcium influx and subsequent excitotoxicity in long-term applications[2][3].	1. Determine the minimal effective concentration of UBP684 for your desired effect through a dose-response curve.2. Reduce the concentration of NMDA receptor agonists (glutamate, glycine) in the medium.3. Consider intermittent application of UBP684 rather than continuous exposure.4. Include viability assays (e.g., PI staining, LDH

assay) in your experimental design.

<p>LT-003</p>	<p>Inconsistent or unexpected effects on different neuronal populations or at different time points.</p>	<p>Subunit-specific effects and agonist concentration: UBP684 exhibits minor subunit-specific effects on agonist potency. For instance, it increases glycine potency at GluN2B-containing receptors and L-glutamate potency at GluN2A-containing receptors[1]. The expression of NMDA receptor subunits can change over time in culture or in different brain regions.</p>	<p>1. Characterize the NMDA receptor subunit composition of your experimental model.2. Be aware that the effects of UBP684 can vary depending on the local concentrations of glutamate and glycine.3. If possible, control for agonist concentrations in your experimental setup.</p>
<p>LT-004</p>	<p>Precipitation of the compound in aqueous solution during long-term storage or experiments.</p>	<p>Limited aqueous solubility and stability: While specific long-term stability data for UBP684 is not readily available, similar small molecules can be prone to precipitation or degradation in aqueous solutions over extended periods, especially at higher concentrations.</p>	<p>1. Prepare fresh stock solutions of UBP684 in a suitable solvent (e.g., DMSO) and dilute to the final working concentration immediately before use.2. For long-term experiments, consider perfusing the compound continuously rather than adding a single bolus to the medium.3. Visually inspect solutions for</p>

any signs of precipitation before and during the experiment.

---

## Frequently Asked Questions (FAQs)

What is the mechanism of action of **UBP684**?

**UBP684** is a positive allosteric modulator (PAM) of NMDA receptors. It does not act at the agonist binding sites for glutamate or glycine but binds to a different site on the receptor. This binding enhances the receptor's response to agonists, increasing the maximal current and slowing the deactivation kinetics[1][2]. It has been suggested that **UBP684** binds to the ligand-binding domain (LBD) dimer interface, stabilizing an active conformation[2][3].

Is **UBP684** specific to any NMDA receptor subtype?

**UBP684** is considered a pan-potentiator, meaning it enhances the function of all four GluN1a/GluN2 receptor subtypes (GluN2A, GluN2B, GluN2C, and GluN2D)[1][4]. However, it does exhibit some minor subtype-specific effects on agonist potency[1].

What is the recommended working concentration for **UBP684**?

The effective concentration of **UBP684** can vary between experimental systems. In studies using *Xenopus* oocytes and HEK293 cells, concentrations around 30  $\mu\text{M}$  produced significant potentiation, with maximal effects observed at approximately 100  $\mu\text{M}$ [1]. It is crucial to perform a dose-response curve to determine the optimal concentration for your specific application to maximize the desired effect while minimizing potential off-target effects or cytotoxicity.

How does pH affect the activity of **UBP684**?

The activity of **UBP684** is highly dependent on the extracellular pH. It is an effective PAM at a physiological pH of 7.4. Its potentiating effect is even greater at a more acidic pH of 6.4. However, at an alkaline pH of 8.4, **UBP684** becomes inhibitory, with the degree of inhibition varying among different GluN2 subunits[1]. This is a critical consideration for long-term experiments where the pH of the medium can fluctuate.

What are the potential off-target effects of **UBP684**?

While the primary target of **UBP684** is the NMDA receptor, the possibility of off-target effects, especially in long-term recordings, should be considered. As with any small molecule, high concentrations may lead to non-specific interactions. It is recommended to use the lowest effective concentration and include appropriate controls in your experiments.

## Quantitative Data Summary

Parameter	Value	Receptor Subtype(s)	Experimental System	Reference
EC50 (Potentiation)	~30 $\mu$ M	GluN1a/GluN2A-D	Xenopus oocytes	[1]
Maximal Potentiation	69% - 117%	GluN1a/GluN2A-D	Xenopus oocytes	[1]
Effect on Agonist Potency	32% reduction in L-glutamate EC50	GluN2A	Xenopus oocytes	[1]
30% reduction in glycine EC50	GluN2B	Xenopus oocytes	[1]	
pH Dependence (pH 7.4)	Potentiation	All GluN2 subtypes	Xenopus oocytes	[1]
pH Dependence (pH 8.4)	Inhibition	All GluN2 subtypes	Xenopus oocytes	[1]

## Experimental Protocols

Protocol for Assessing pH-Dependent Effects of **UBP684**

- Cell Preparation: Prepare cells expressing the NMDA receptor subtype of interest (e.g., HEK293 cells transfected with GluN1 and a specific GluN2 subunit).
- Solution Preparation: Prepare extracellular recording solutions buffered to different pH values (e.g., 6.4, 7.4, and 8.4) using a suitable buffer such as HEPES. The solutions should

contain NMDA receptor agonists (e.g., 10  $\mu$ M L-glutamate and 10  $\mu$ M glycine). Prepare a stock solution of **UBP684** in a suitable solvent (e.g., DMSO) and a working solution diluted in the recording buffer.

- Electrophysiological Recording:
  - Perform whole-cell patch-clamp recordings.
  - Establish a baseline response by perfusing the cells with the pH 7.4 recording solution containing the agonists.
  - To test the effect of **UBP684**, co-apply the compound (e.g., 100  $\mu$ M) with the agonists at pH 7.4 and record the potentiated current.
  - Wash out **UBP684** and allow the response to return to baseline.
  - Switch the perfusion to the recording solution with a different pH (e.g., 8.4) containing the agonists and establish a new baseline.
  - Co-apply **UBP684** with the agonists at the new pH and record the response.
  - Repeat for all desired pH values.
- Data Analysis: Measure the peak current amplitude in the presence and absence of **UBP684** at each pH. Calculate the percentage of potentiation or inhibition.

## Visualizations

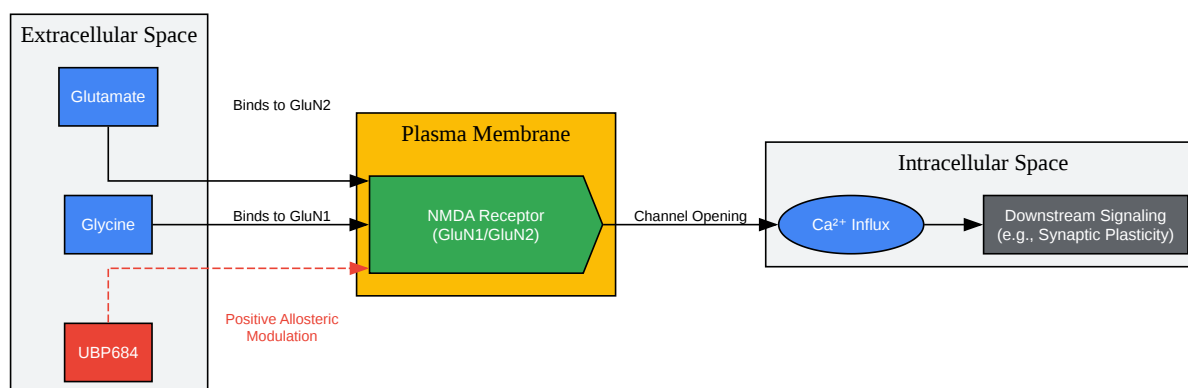

[Click to download full resolution via product page](#)

Caption: Signaling pathway of **UBP684** as a positive allosteric modulator of the NMDA receptor.

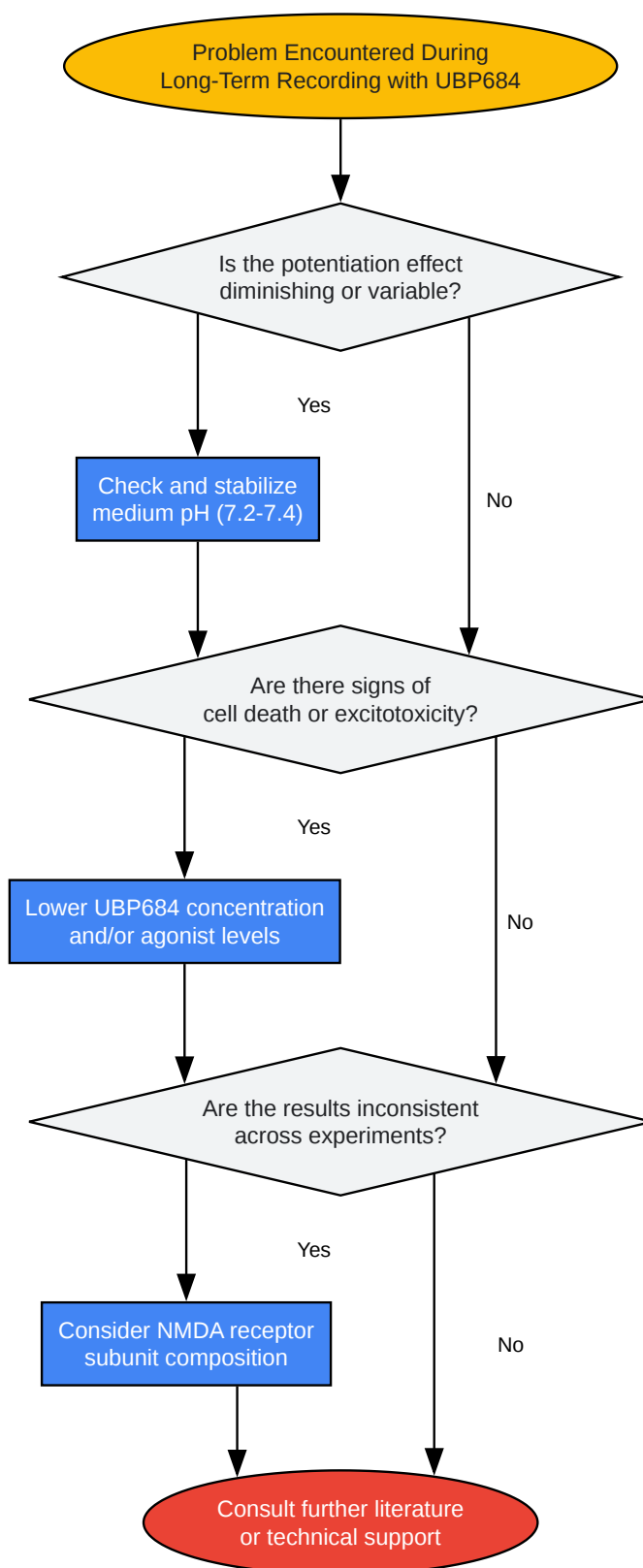

[Click to download full resolution via product page](#)

Caption: A logical workflow for troubleshooting common issues with **UBP684** in long-term recordings.

### Need Custom Synthesis?

BenchChem offers custom synthesis for rare earth carbides and specific isotopic labeling.

Email: [info@benchchem.com](mailto:info@benchchem.com) or [Request Quote Online](#).

## References

- 1. Mechanism and properties of positive allosteric modulation of N-Methyl-D-Aspartate receptors by 6-alkyl 2-naphthoic acid derivatives - PMC [[pmc.ncbi.nlm.nih.gov](https://pubmed.ncbi.nlm.nih.gov/)]
- 2. [researchgate.net](https://www.researchgate.net/) [[researchgate.net](https://www.researchgate.net/)]
- 3. Research Portal [[researchworks.creighton.edu](https://researchworks.creighton.edu/)]
- 4. UBP684 | 1357838-47-1 | Benchchem [[benchchem.com](https://www.benchchem.com/)]
- To cite this document: BenchChem. [common problems with UBP684 in long-term recordings]. BenchChem, [2026]. [Online PDF]. Available at: [<https://www.benchchem.com/product/b11927763/docs#common-problems-with-ubp684-in-long-term-recordings>]

---

### Disclaimer & Data Validity:

The information provided in this document is for Research Use Only (RUO) and is strictly not intended for diagnostic or therapeutic procedures. While BenchChem strives to provide accurate protocols, we make no warranties, express or implied, regarding the fitness of this product for every specific experimental setup.

**Technical Support:** The protocols provided are for reference purposes. Unsure if this reagent suits your experiment?

**Need Industrial/Bulk Grade?** [Request Custom Synthesis Quote](#)

# BenchChem

Our mission is to be the trusted global source of essential and advanced chemicals, empowering scientists and researchers to drive progress in science and industry.

## Contact

Address: 3281 E Guasti Rd

Ontario, CA 91761, United States

Phone: (601) 213-4426

Email: [info@benchchem.com](mailto:info@benchchem.com)

[Contact our Ph.D. Support Team for a compatibility check](#)