

Technical Support Center: Optimizing Patch Clamp Recordings with UBP684

Author: BenchChem Technical Support Team. **Date:** April 2026

Compound of Interest

Compound Name: UBP684
Cat. No.: B11927763

[Get Quote](#)

This technical support center provides troubleshooting guidance and frequently asked questions (FAQs) for researchers, scientists, and drug development professionals utilizing **UBP684** in patch clamp experiments. The focus is on ensuring optimal experimental conditions and maintaining high-quality, stable seals for accurate data acquisition.

Troubleshooting Guide: Seal Stability in the Presence of UBP684

Achieving and maintaining a high-resistance seal (gigaseal) is paramount for successful patch clamp recordings. While **UBP684** is a valuable tool for studying NMDA receptor function, certain experimental parameters can influence seal stability. This guide addresses common issues in a question-and-answer format.

Q1: I'm having trouble forming a stable gigaseal when **UBP684** is in the external solution. What could be the cause?

A1: Several factors can contribute to difficulties in forming a stable gigaseal. When using **UBP684**, pay close attention to the following:

- Solution pH: **UBP684**'s activity is highly pH-dependent.[1] It acts as a positive allosteric modulator (PAM) at pH 7.4 but can be inhibitory at pH 8.4.[1] Drastic shifts in extracellular pH can affect both the compound's efficacy and membrane stability. Ensure your external solution is buffered to a stable pH of 7.4.
- Solution Quality: Always use freshly prepared and filtered (0.22 μm) solutions to remove any particulate matter that could interfere with seal formation.[2][3]
- Pipette Preparation: The cleanliness and geometry of your patch pipette are critical. Fire-polishing the pipette tip can create a smoother surface, which often improves the quality and stability of the seal.[4]
- Cell Health: Only use healthy, viable cells for patching. Unhealthy or dying cells will not form stable seals.

Q2: My seal forms initially but deteriorates over time during the recording with **UBP684**. How can I improve stability?

A2: Seal deterioration during a recording can be frustrating. Consider these troubleshooting steps:

- Mechanical Stability: Ensure your entire patch clamp setup is free from vibrations. Use an anti-vibration table and check for any drift in the micromanipulator or microscope stage.[4][5]
- Osmolarity: Mismatched osmolarity between your internal and external solutions can cause osmotic stress on the cell, leading to an unstable seal.[4] Measure and adjust the osmolarity of all solutions.
- Recording Configuration: The potentiating effect of **UBP684** on NMDA receptors has been shown to be more pronounced in perforated-patch recordings compared to whole-cell dialyzed recordings.[6] If you are using the whole-cell configuration, be aware that intracellular factors that are normally "washed out" might play a role in the receptor's response to **UBP684**. While not directly linked to seal stability, this highlights the importance of the chosen recording mode.
- Laminar Flow: For long-duration recordings, a stable seal is crucial. Studies have shown that a gentle, continuous laminar flow of the external solution across the cell can enhance seal

stability and prolong recording times.[7]

Frequently Asked Questions (FAQs) about **UBP684** in Patch Clamp

Q1: What is the mechanism of action of **UBP684**?

A1: **UBP684** is a positive allosteric modulator (PAM) of N-Methyl-D-Aspartate (NMDA) receptors.[1][8] It does not directly activate the receptor but enhances the response to the binding of the primary agonists, glutamate and glycine.[1][6] It achieves this by increasing the channel open probability and slowing the receptor's deactivation rate.[6][8]

Q2: How does pH affect **UBP684**'s activity?

A2: The modulatory effect of **UBP684** on NMDA receptors is strongly dependent on the extracellular pH. At a physiological pH of 7.4, **UBP684** potentiates NMDA receptor currents. However, at a more alkaline pH of 8.4, it can act as an inhibitor.[1] Conversely, its potentiating effect is even greater at a more acidic pH of 6.4.[1]

Q3: What concentrations of **UBP684** are typically used in patch clamp experiments?

A3: The effective concentration of **UBP684** can vary depending on the specific NMDA receptor subtype and the experimental conditions. Studies have shown potentiation of NMDA receptor responses with **UBP684** concentrations in the range of 30 μ M to 100 μ M.[1][6]

Q4: Does **UBP684** have any subtype selectivity for NMDA receptors?

A4: **UBP684** potentiates responses at all four GluN1a/GluN2 receptor subtypes (GluN2A, GluN2B, GluN2C, and GluN2D).[1] However, its effects on agonist potency can be subunit-specific. For example, at GluN2A-containing receptors, **UBP684** primarily increases the potency of L-glutamate, whereas at GluN2B-containing receptors, it mainly enhances the potency of glycine.[1]

Quantitative Data Summary

The following table summarizes the key quantitative effects of **UBP684** on NMDA receptor function as reported in the literature.

Parameter	Receptor Subtype	UBP684 Concentration	Effect	Reference
Maximal Potentiation	GluN1a/GluN2A-D	~30 μ M (EC50)	69% to 117% increase	[1]
L-glutamate EC50	GluN1a/GluN2A	Not Specified	32% reduction	[1]
Glycine EC50	GluN1a/GluN2B	Not Specified	30% reduction	[1]
Whole-cell Current	GluN1/GluN2A	100 μ M	~Two-fold increase (perforated patch)	[6]

Experimental Protocols

Standard Patch Clamp Protocol for Evaluating **UBP684**

This protocol provides a general framework for whole-cell patch clamp recordings to assess the effect of **UBP684** on NMDA receptor currents.

- Cell Culture: Culture cells expressing the NMDA receptor subunits of interest (e.g., HEK293 cells transfected with GluN1 and GluN2A).
- Solution Preparation:
 - External Solution (in mM): 140 NaCl, 2.8 KCl, 1 CaCl₂, 10 HEPES, 10 Glucose. Adjust pH to 7.4 with NaOH.
 - Internal Solution (in mM): 140 CsCl, 10 HEPES, 10 EGTA, 2 Mg-ATP, 0.2 Na-GTP. Adjust pH to 7.2 with CsOH.
 - Filter all solutions through a 0.22 μ m filter before use.[2]
- Pipette Fabrication: Pull borosilicate glass capillaries to a resistance of 3-5 M Ω when filled with the internal solution. Fire-polish the pipette tips to ensure a smooth surface.[4]

- Recording Procedure:
 - Obtain a gigaseal (>1 GΩ) on a healthy cell.
 - Rupture the membrane to achieve the whole-cell configuration.
 - Hold the cell at a membrane potential of -60 mV.
 - Apply agonists (e.g., 100 μM L-glutamate and 10 μM glycine) to elicit a baseline NMDA receptor current.
 - After establishing a stable baseline, co-apply the agonists with the desired concentration of **UBP684**.
 - Wash out **UBP684** with the agonist-containing external solution to observe the reversal of the effect.
- Data Analysis: Measure the peak amplitude and deactivation kinetics of the NMDA receptor currents in the absence and presence of **UBP684**.

Visualizations

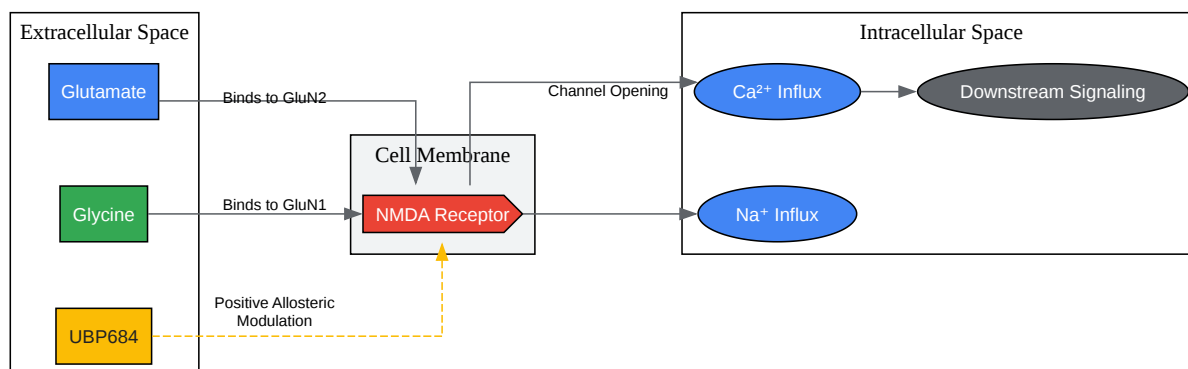

[Click to download full resolution via product page](#)

Caption: Signaling pathway of NMDA receptor activation and modulation by **UBP684**.

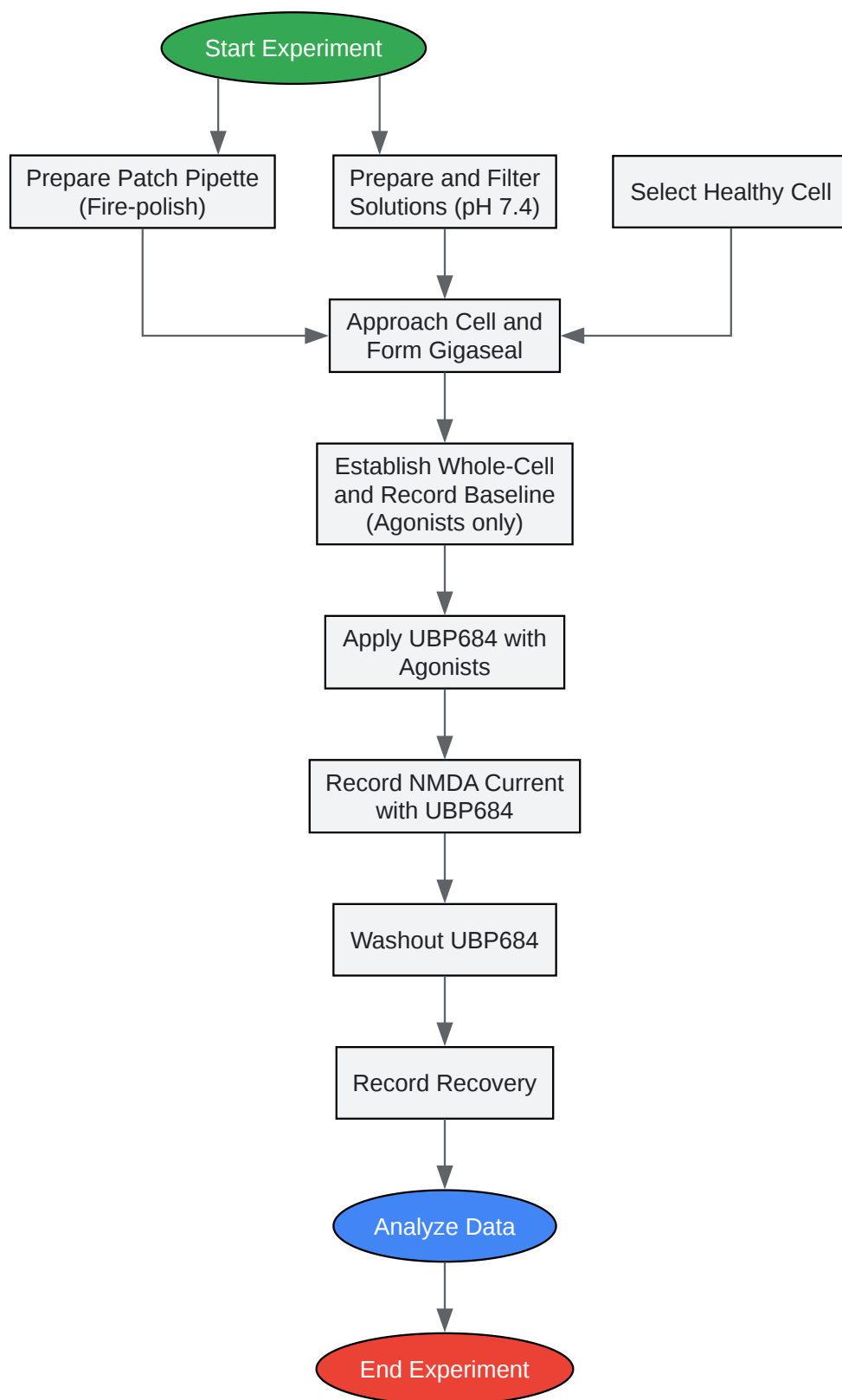

[Click to download full resolution via product page](#)

Caption: Experimental workflow for a patch clamp experiment with **UBP684**.

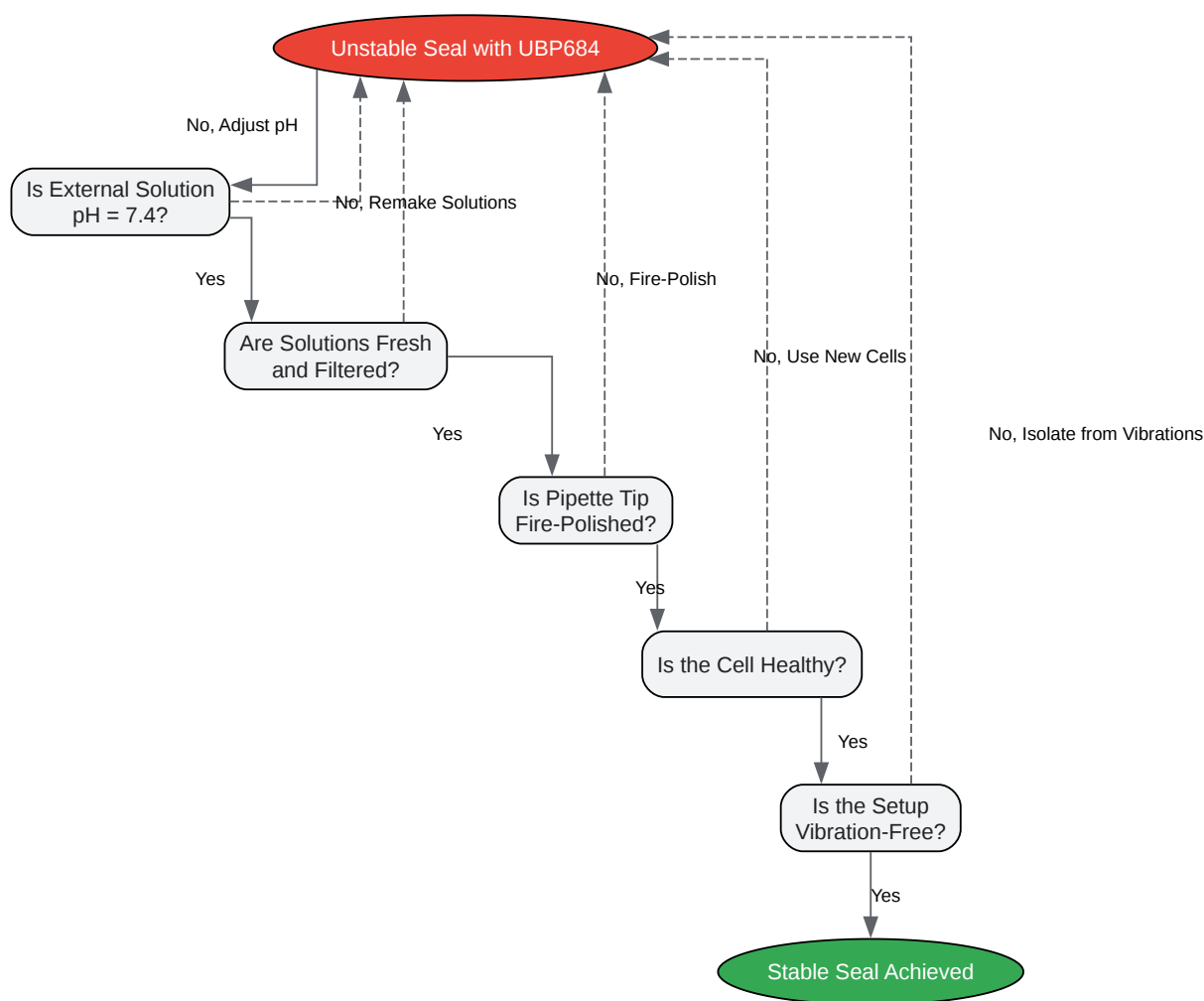

[Click to download full resolution via product page](#)

Caption: Troubleshooting logic for addressing seal stability issues.

Need Custom Synthesis?

BenchChem offers custom synthesis for rare earth carbides and specific isotopic labeling.

Email: info@benchchem.com or [Request Quote Online](#).

References

- 1. Mechanism and properties of positive allosteric modulation of N-Methyl-D-Aspartate receptors by 6-alkyl 2-naphthoic acid derivatives - PMC [[pmc.ncbi.nlm.nih.gov](https://pubmed.ncbi.nlm.nih.gov)]
- 2. Troubleshooting patch clamping - G23 Instruments [g23instruments.com]
- 3. [scientifica.uk.com](https://www.scientifica.uk.com) [[scientifica.uk.com](https://www.scientifica.uk.com)]
- 4. [benchchem.com](https://www.benchchem.com) [[benchchem.com](https://www.benchchem.com)]
- 5. docs.axolbio.com [docs.axolbio.com]
- 6. [researchgate.net](https://www.researchgate.net) [[researchgate.net](https://www.researchgate.net)]
- 7. Stabilization of high-resistance seals in patch-clamp recordings by laminar flow - PubMed [pubmed.ncbi.nlm.nih.gov]
- 8. A single-channel mechanism for pharmacological potentiation of GluN1/GluN2A NMDA receptors - PubMed [pubmed.ncbi.nlm.nih.gov]
- To cite this document: BenchChem. [Technical Support Center: Optimizing Patch Clamp Recordings with UBP684]. BenchChem, [2026]. [Online PDF]. Available at: [<https://www.benchchem.com/product/b11927763/docs#technical-support-center-optimizing-patch-clamp-recordings-with-ubp684>]

Disclaimer & Data Validity:

The information provided in this document is for Research Use Only (RUO) and is strictly not intended for diagnostic or therapeutic procedures. While BenchChem strives to provide accurate protocols, we make no warranties, express or implied, regarding the fitness of this product for every specific experimental setup.

Technical Support: The protocols provided are for reference purposes. Unsure if this reagent suits your experiment?

Need Industrial/Bulk Grade? [Request Custom Synthesis Quote](#)

BenchChem

Our mission is to be the trusted global source of essential and advanced chemicals, empowering scientists and researchers to drive progress in science and industry.

Contact

Address: 3281 E Guasti Rd
Ontario, CA 91761, United States
Phone: (601) 213-4426
Email: info@benchchem.com

[Contact our Ph.D. Support Team for a compatibility check](#)