

TFAX 594,SE Low Labeling Efficiency: Technical Support Center

Author: BenchChem Technical Support Team. **Date:** April 2026

Compound of Interest

Compound Name: Tfax 594,SE

Cat. No.: B11927528

[Get Quote](#)

This technical support center provides troubleshooting guidance and frequently asked questions (FAQs) for researchers, scientists, and drug development professionals experiencing low labeling efficiency with **TFAX 594,SE**.

Frequently Asked Questions (FAQs) & Troubleshooting

Q1: What are the most common causes of low labeling efficiency with **TFAX 594,SE**?

Low labeling efficiency with succinimidyl ester (SE) dyes like **TFAX 594,SE** can stem from several factors. The most critical are suboptimal pH, the presence of primary amines in the buffer, low protein concentration, and improper dye storage.[1] The reactivity of SE esters is highly dependent on pH, with optimal labeling occurring at a pH range of 8.5-9.5.[1] Buffers containing primary amines, such as Tris or glycine, will compete with the protein for reaction with the dye, significantly reducing labeling efficiency.[1]

Q2: My labeling efficiency is still low after optimizing the pH and buffer. What else could be wrong?

If the pH and buffer composition are correct, consider the following:

- **Protein Concentration:** The concentration of the protein solution should ideally be between 2-10 mg/mL for optimal labeling.^[1] Lower concentrations can significantly decrease the labeling efficiency.
- **Dye Quality:** **TFAX 594,SE** should be dissolved in anhydrous DMSO or DMF immediately before use. Extended storage of the dye stock solution can lead to hydrolysis and reduced reactivity.
- **Dye-to-Protein Molar Ratio:** An inappropriate molar ratio of dye to protein can lead to either under- or over-labeling. For antibodies, a starting point of 4-10 moles of dye per mole of protein is recommended.
- **Reaction Temperature and Time:** Most labeling reactions are carried out at room temperature for 1-2 hours. However, for particularly sensitive proteins, the reaction can be performed at 4°C for a longer duration, such as overnight.

Q3: Can the presence of other substances in my protein solution affect labeling?

Yes, substances other than the target protein can interfere with the labeling reaction. It is crucial to remove any components that contain primary amines. This includes:

- **Buffers:** Tris, glycine, and ammonium salts (e.g., ammonium sulfate) must be removed before labeling.
- **Protein Stabilizers:** Additives like bovine serum albumin (BSA) or gelatin contain primary amines and will compete for the dye.

Dialysis or buffer exchange into a suitable labeling buffer like phosphate-buffered saline (PBS) or sodium bicarbonate buffer is highly recommended.

Q4: I observe precipitation of my protein during the labeling reaction. What should I do?

Protein precipitation during labeling can occur if the dye concentration is too high or if the labeling modifies lysine residues critical for protein solubility. To mitigate this, try reducing the dye-to-protein molar ratio.

Q5: My labeled protein has low fluorescence even with a good degree of labeling. What could be the issue?

Low fluorescence despite successful labeling can be due to dye-dye quenching, which happens when too many fluorophores are attached to a single protein molecule. This is more common with higher degrees of labeling. It's also possible that the fluorophore is in a microenvironment on the protein that quenches its fluorescence. Determining the degree of labeling (DOL) is crucial to troubleshoot this issue.

Key Experimental Parameters

For successful labeling of proteins with **TFAX 594,SE**, it is essential to control several experimental parameters. The table below summarizes the key quantitative data for easy reference.

Parameter	Recommended Range/Value	Notes
pH	8.5 - 9.5	The labeling reaction is strongly pH-dependent.
Labeling Buffer	0.1 M Sodium Bicarbonate or PBS	Must be free of primary amines (e.g., Tris, glycine).
Protein Concentration	2 - 10 mg/mL	Lower concentrations reduce labeling efficiency.
Dye Solvent	Anhydrous DMSO or DMF	Prepare fresh before use.
Dye Stock Concentration	10 - 20 mM	Store protected from light and moisture for no more than two weeks.
Dye:Protein Molar Ratio	4:1 to 10:1 (for Antibodies)	This may need to be optimized for different proteins.
Reaction Temperature	Room Temperature (or 4°C)	
Reaction Time	1 - 2 hours (or overnight at 4°C)	

Experimental Protocols

Protein Labeling with TFX 594,SE

This protocol provides a general procedure for labeling proteins with **TFAX 594,SE**.

- Prepare the Protein Solution:
 - Dissolve the protein in 0.1 M sodium bicarbonate buffer (pH 8.5-9.5) to a final concentration of 2-10 mg/mL.
 - If the protein is in a buffer containing primary amines (e.g., Tris, glycine), perform buffer exchange into the labeling buffer.
- Prepare the Dye Stock Solution:
 - Allow the vial of **TFAX 594,SE** to warm to room temperature before opening.
 - Add the appropriate volume of anhydrous DMSO to create a 10-20 mM stock solution.
 - Vortex briefly to ensure the dye is fully dissolved. This solution should be used promptly.
- Labeling Reaction:
 - While gently stirring the protein solution, add the calculated volume of the **TFAX 594,SE** stock solution.
 - Incubate the reaction mixture for 1-2 hours at room temperature, protected from light.
- Purification of the Labeled Protein:
 - Separate the labeled protein from the unreacted dye using size-exclusion chromatography (e.g., a desalting column).
 - Collect the fractions containing the labeled protein.

Determining the Degree of Labeling (DOL)

The DOL is the average number of dye molecules conjugated to each protein molecule.

- Measure Absorbance:
 - Measure the absorbance of the purified protein-dye conjugate at 280 nm (for protein) and at the absorbance maximum for TFX 594 (approximately 594 nm).
- Calculate the DOL:
 - The DOL can be calculated using the following formula: $DOL = (A_{max} * \epsilon_{protein}) / ((A_{280} - (A_{max} * CF)) * \epsilon_{dye})$ Where:
 - A_{max} is the absorbance at the dye's maximum absorption wavelength.
 - A_{280} is the absorbance at 280 nm.
 - $\epsilon_{protein}$ is the molar extinction coefficient of the protein at 280 nm.
 - ϵ_{dye} is the molar extinction coefficient of the dye at its A_{max} .
 - CF is the correction factor for the dye's absorbance at 280 nm.

Visual Guides

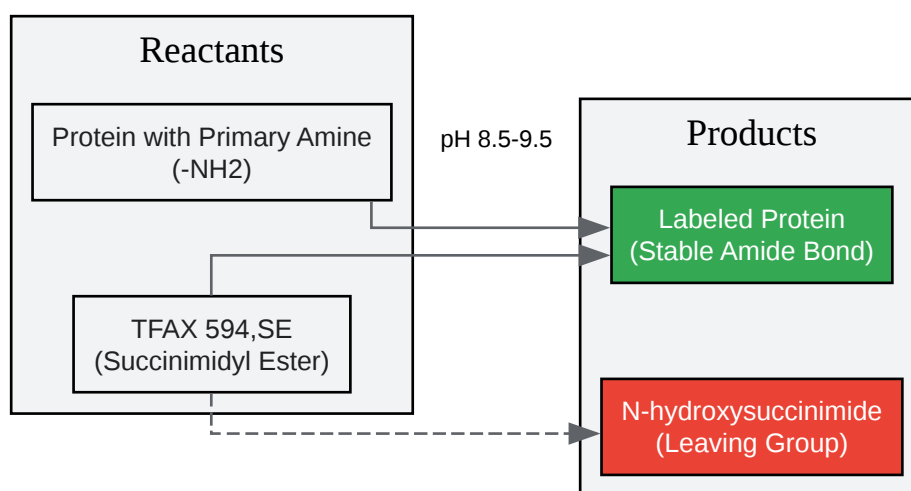

[Click to download full resolution via product page](#)

Caption: Chemical reaction pathway of **TFX 594,SE** with a protein's primary amine.

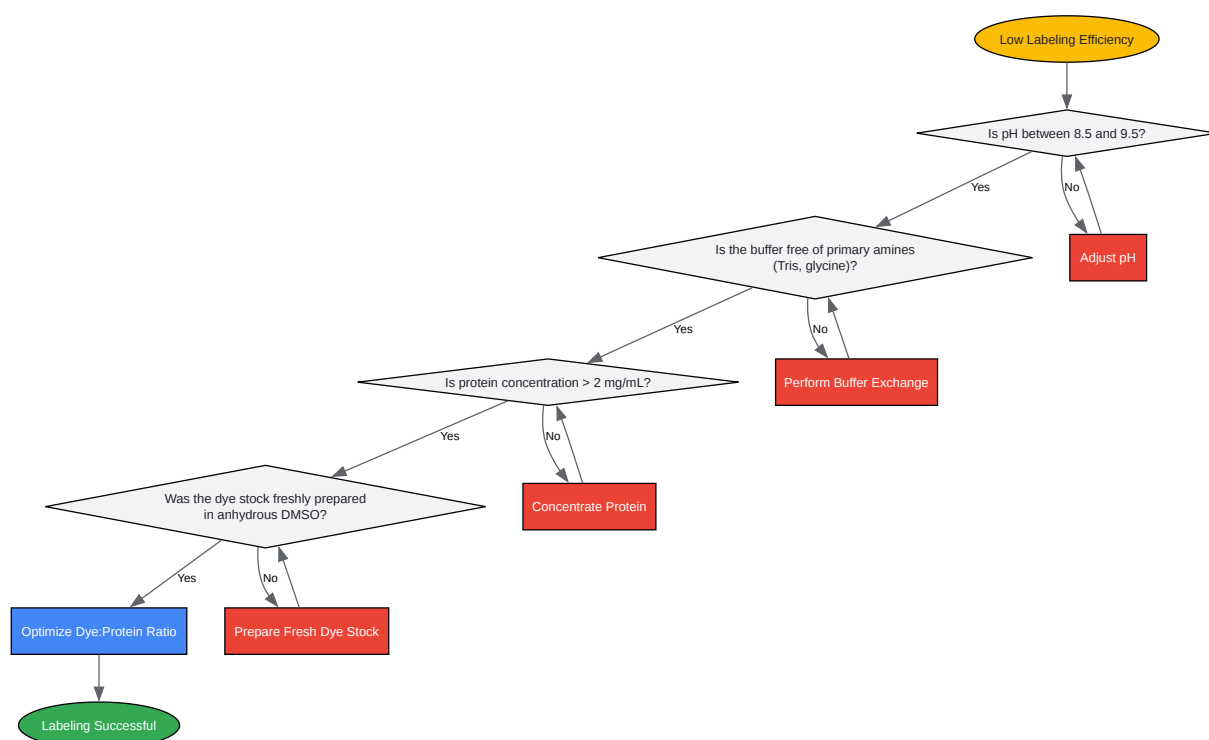

[Click to download full resolution via product page](#)

Caption: Troubleshooting workflow for low labeling efficiency.

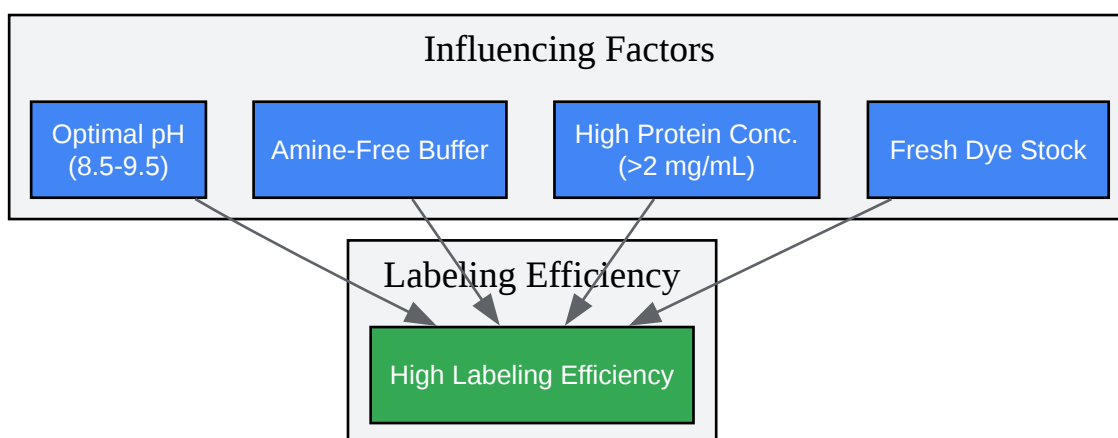

[Click to download full resolution via product page](#)

Caption: Key factors influencing high labeling efficiency.

Need Custom Synthesis?

BenchChem offers custom synthesis for rare earth carbides and specific isotopic labeling.

Email: info@benchchem.com or [Request Quote Online](#).

References

- 1. ulab360.com [ulab360.com]
- To cite this document: BenchChem. [TFAX 594, SE Low Labeling Efficiency: Technical Support Center]. BenchChem, [2026]. [Online PDF]. Available at: [\[https://www.benchchem.com/product/b11927528/docs#tfax-594-se-low-labeling-efficiency-technical-support-center\]](https://www.benchchem.com/product/b11927528/docs#tfax-594-se-low-labeling-efficiency-technical-support-center)

Disclaimer & Data Validity:

The information provided in this document is for Research Use Only (RUO) and is strictly not intended for diagnostic or therapeutic procedures. While BenchChem strives to provide accurate protocols, we make no warranties, express or implied, regarding the fitness of this product for every specific experimental setup.

Technical Support: The protocols provided are for reference purposes. Unsure if this reagent suits your experiment?

Need Industrial/Bulk Grade? [Request Custom Synthesis Quote](#)

BenchChem

Our mission is to be the trusted global source of essential and advanced chemicals, empowering scientists and researchers to drive progress in science and industry.

Contact

Address: 3281 E Guasti Rd
Ontario, CA 91761, United States
Phone: (601) 213-4426
Email: info@benchchem.com

[Contact our Ph.D. Support Team for a compatibility check](#)