

Technical Support Center: Enhancing Enantioselectivity in Chiral Cyclopropylamine Synthesis

Author: BenchChem Technical Support Team. **Date:** April 2026

Compound of Interest

Compound Name: (1-(Pyrimidin-2-yl)cyclopropyl)methanamine

Cat. No.: B11923970

[Get Quote](#)

Welcome to the technical support center dedicated to the synthesis of chiral cyclopropylamine derivatives. This guide is designed for researchers, scientists, and professionals in drug development who are navigating the complexities of asymmetric cyclopropanation. Here, we address common challenges and provide in-depth, field-proven insights to help you improve the enantioselectivity of your reactions.

Frequently Asked Questions (FAQs)

Q1: I'm observing low enantiomeric excess (ee) in my cyclopropanation reaction. What are the first things I should check?

A1: Low enantioselectivity is a common hurdle. Before delving into extensive optimization, it's crucial to verify the fundamentals of your experimental setup. Start with a systematic check of the following:

- **Reagent and Solvent Purity:** Impurities in your starting materials, reagents, or catalyst can interfere with the catalytic cycle, leading to a non-selective background reaction.^{[1][2]} Ensure

all chemicals are of high purity and that your solvent is anhydrous, as water can deactivate many catalysts.[1]

- **Reaction Temperature:** Temperature is a critical parameter. Even minor fluctuations can significantly impact the energy difference between the diastereomeric transition states.[1] Double-check your temperature control.
- **Inert Atmosphere:** Many catalysts used in asymmetric cyclopropanation are sensitive to air and moisture.[3] Ensure your reaction is conducted under a strictly inert atmosphere (e.g., nitrogen or argon).
- **Measurements and Concentrations:** Simple experimental errors in measurements can lead to incorrect stoichiometry. Re-verify all concentrations and amounts.[1]

Q2: My catalyst doesn't seem to be performing as expected. How can I troubleshoot the catalyst itself?

A2: Catalyst performance is central to achieving high enantioselectivity. If you suspect an issue with your catalyst, consider the following:

- **Catalyst Integrity:** For in-house prepared catalysts, especially chiral ligand-metal complexes, verify their purity and structural integrity using techniques like NMR or X-ray crystallography. [1]
- **Commercial Catalyst Handling:** If using a commercial catalyst, ensure it is from a reputable supplier and has been stored under the recommended conditions to prevent decomposition. [2]
- **Control Reaction:** Run a control experiment with a well-established substrate that is known to give high enantiomeric excess with your catalyst system.[1] If this reaction also results in low ee, it strongly indicates a problem with the catalyst.
- **Catalyst Loading:** Both too low and too high catalyst loadings can negatively impact enantioselectivity. Insufficient catalyst may allow a non-catalyzed background reaction to dominate, while high concentrations can lead to the formation of less selective catalyst aggregates.[2]

Q3: How significant is the choice of solvent in determining enantioselectivity?

A3: The choice of solvent can have a profound impact on the enantioselectivity of an asymmetric reaction.^[1] The solvent influences the conformation of the catalyst-substrate complex and the energies of the transition states for the two enantiomeric pathways.^[1] For instance, non-coordinating solvents like dichloromethane (DCM) or dichloroethane (DCE) are often preferred in many cyclopropanation reactions.^[3] It is highly recommended to screen a range of solvents with varying polarities and coordinating abilities to find the optimal medium for your specific reaction.

Troubleshooting Guide: Specific Issues

Issue 1: Poor Diastereoselectivity (cis/trans Ratio)

Q: My reaction produces a nearly 1:1 mixture of cis and trans isomers, and I need to favor one. What factors can I modify?

A: Controlling diastereoselectivity is often a prerequisite for achieving high enantioselectivity. The cis/trans ratio is primarily influenced by the catalyst system and reaction conditions.

- **Catalyst Choice:** The metal center and the ligand structure are critical. For example, certain ruthenium-based catalysts are known to favor the formation of cis cyclopropanes, whereas many rhodium and copper catalysts tend to favor the trans product, particularly with bulky ligands.^[3] Cobalt porphyrin catalysts have also shown tunable diastereoselectivity based on the porphyrin ligand or additives.^{[4][5]}
- **Ligand Sterics:** The steric bulk of the ligands on the metal catalyst can direct the approach of the alkene, thereby influencing the stereochemical outcome.^[3]
- **Carbene Source:** The steric bulk of the carbene precursor can also influence the approach to the alkene and affect diastereoselectivity.^[3]
- **Reaction Temperature:** Lowering the reaction temperature can often enhance diastereoselectivity by favoring the transition state with the lower activation energy.^[3]

Issue 2: Inconsistent Enantioselectivity Between Batches

Q: I'm getting variable enantiomeric excess values when I repeat the reaction. What could be causing this inconsistency?

A: Inconsistent results often point to subtle variations in experimental conditions or reagent quality.

- **Reagent Purity:** As mentioned in the FAQs, impurities are a major culprit. Ensure you are using reagents from the same lot or re-purify them if necessary.
- **Water and Oxygen Contamination:** Even trace amounts of water or oxygen can affect catalyst activity and selectivity. Re-evaluate your procedures for drying solvents and maintaining an inert atmosphere.
- **Rate of Addition:** In reactions involving the slow addition of a reagent (e.g., a diazo compound), the addition rate can be critical. Use a syringe pump for precise and reproducible addition.^[3]
- **Stirring and Mixing:** In heterogeneous reactions, or reactions with viscous solutions, inefficient stirring can lead to localized concentration gradients and poor reproducibility.

Advanced Optimization Strategies

Q: I've addressed the basic issues, but my enantioselectivity is still moderate. What advanced strategies can I employ?

A: When basic troubleshooting is insufficient, a more systematic optimization of reaction parameters is necessary.

Parameter Screening

A common strategy to improve enantioselectivity is to screen a variety of reaction parameters. The following table provides a starting point for your optimization studies.

Parameter	Variables to Screen	Rationale
Chiral Ligand	Different ligand backbones (e.g., BOX, PYBOX, Salen), varying steric and electronic properties.	The chiral ligand is the primary source of stereochemical information. A different ligand may provide a better-matched chiral environment for your substrate.[6]
Metal Precursor	Different metal salts (e.g., Cu(I), Cu(II), Rh(II), Co(II), Ru(II)) and counterions.	The metal center's Lewis acidity and coordination geometry are crucial for catalysis.[3][4]
Solvent	A range of polar and non-polar, coordinating and non-coordinating solvents.	To optimize the catalyst-substrate complex conformation and transition state energies.[1]
Temperature	A range of temperatures, often from room temperature down to -78 °C.	Lower temperatures generally lead to higher enantioselectivity by amplifying the small energy differences between diastereomeric transition states.[1][3]
Additives	Co-catalysts, Lewis acids, or bases.	Additives can influence the catalytic cycle, for example, by promoting catalyst activation or preventing deactivation.

Workflow for Troubleshooting Low Enantioselectivity

The following diagram illustrates a logical workflow for systematically troubleshooting low enantiomeric excess.

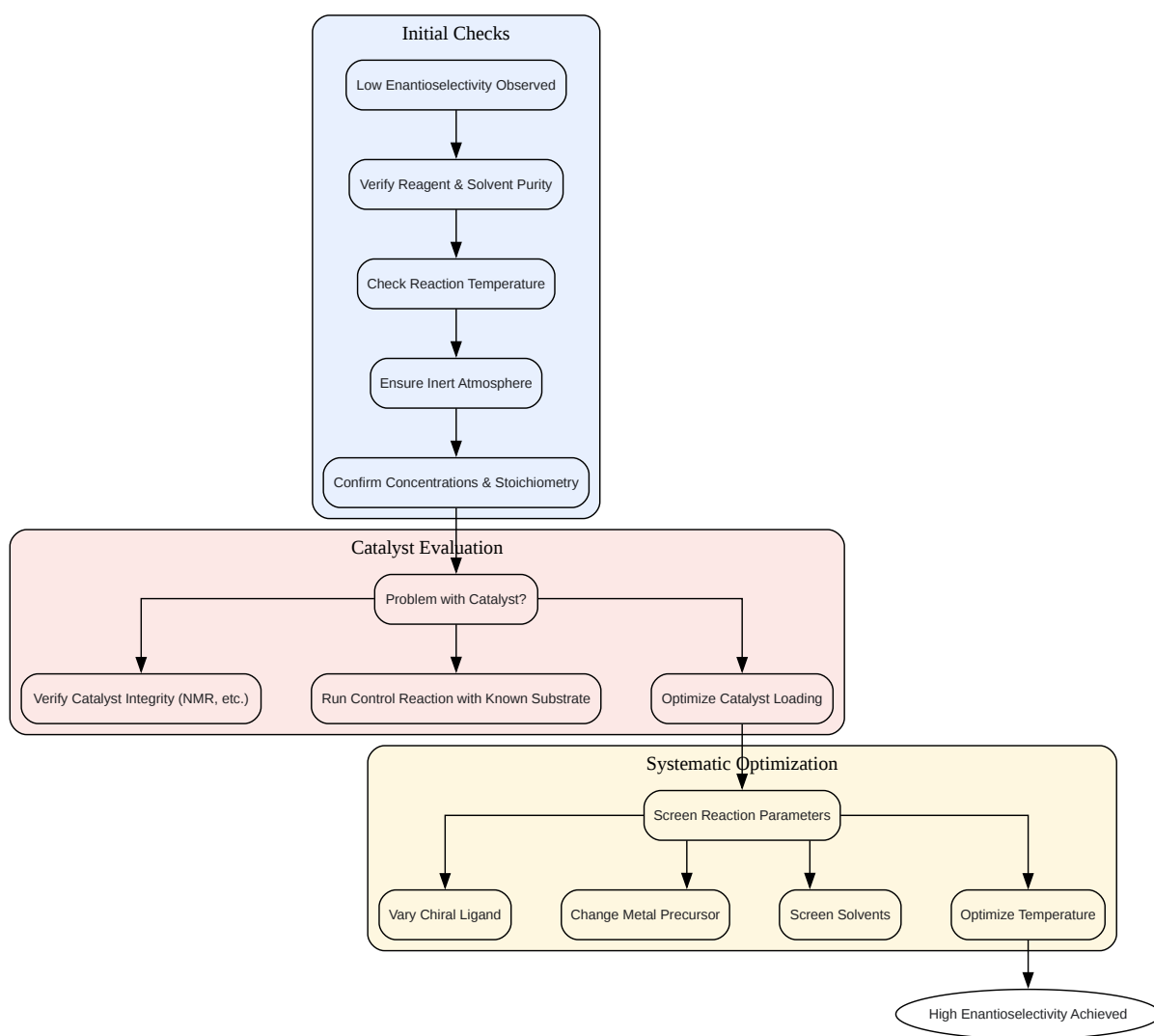

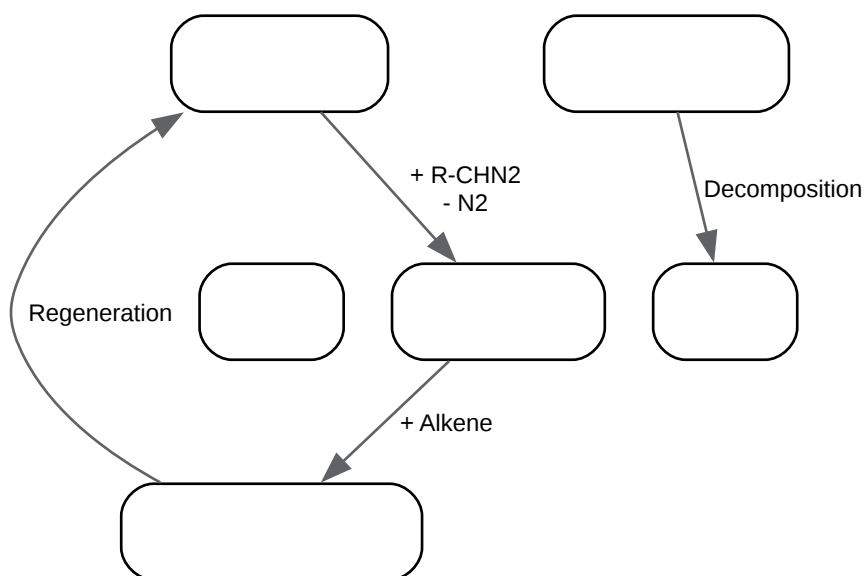

[Click to download full resolution via product page](#)

Caption: Simplified catalytic cycle for metal-catalyzed cyclopropanation.

References

- Organocatalytic enantio- and diastereoselective assembly of cyclopropane-incorporated polycyclic molecules via isobenzopyrylium ions. PMC. Available at: [\[Link\]](#)
- Diastereoselective and Enantioselective Cyclopropanation of Alkenes Catalyzed by Cobalt Porphyrins. The Journal of Organic Chemistry - ACS Publications. Available at: [\[Link\]](#)
- High-Diastereoselective and Enantioselective Cyclopropanation of α,β -Unsaturated Fischer Carbene Complexes: Synthesis of Chiral 1,2-Disubstituted and 1,2,3-Trisubstituted Cyclopropanes. The Journal of Organic Chemistry - ACS Publications. Available at: [\[Link\]](#)
- Diastereoselective and enantioselective cyclopropanation of alkenes catalyzed by cobalt porphyrins. PubMed. Available at: [\[Link\]](#)
- Highly Diastereo- and Enantioselective Synthesis of Nitrile-Substituted Cyclopropanes by Myoglobin-Mediated Carbene Transf. University of Rochester. Available at: [\[Link\]](#)
- Exceptional Selectivity in Cyclopropanation Reactions Catalyzed by Chiral Cobalt(II) Porphyrins. PMC. Available at: [\[Link\]](#)

- Stereoselective Cyclopropanation Reactions. Docentes FCT NOVA. Available at: [\[Link\]](#)
- Unveiling the beauty of cyclopropane formation: a comprehensive survey of enantioselective Michael initiated ring closure (MIRC) reactions. Organic Chemistry Frontiers (RSC Publishing). DOI:10.1039/D4QO00535J. Available at: [\[Link\]](#)
- Optimization of an Enantioselective Cyclopropanation Reaction Mediated by $[Au(6)(Cl)]$ a. ResearchGate. Available at: [\[Link\]](#)
- Enantioselective Cyclopropanation Catalyzed by Gold(I)-Carbene Complexes. PMC. Available at: [\[Link\]](#)
- Highly stereoselective and enantiodivergent synthesis of cyclopropylphosphonates with engineered carbene transferases. University of Rochester. Available at: [\[Link\]](#)
- An Enzymatic Platform for the Highly Enantioselective and Stereodivergent Construction of Cyclopropyl- δ -lactones. University of Rochester. Available at: [\[Link\]](#)
- Assembly of polysubstituted chiral cyclopropylamines via highly enantioselective Cu-catalyzed three-component cyclopropene alkenylation. Chemical Communications (RSC Publishing). Available at: [\[Link\]](#)
- Advances in the Synthesis of Cyclopropylamines. PubMed. Available at: [\[Link\]](#)
- Enantioselective synthesis of chiral BCPs. Organic Chemistry Frontiers (RSC Publishing). Available at: [\[Link\]](#)
- Catalytic Enantioselective Ring-Opening Reactions of Cyclopropanes. Xingwei Li. Available at: [\[Link\]](#)
- Highly Enantioselective Synthesis of Chiral Cyclopropyl Nucleosides via Catalytic Asymmetric Intermolecular Cyclopropanation. Organic Letters - ACS Publications. Available at: [\[Link\]](#)
- A Diverse Library of Chiral Cyclopropane Scaffolds via Chemoenzymatic Assembly and Diversification of Cyclopropyl Ketones. PMC. Available at: [\[Link\]](#)

- Advances in the Synthesis of Cyclopropylamines. Request PDF - ResearchGate. Available at: [\[Link\]](#)
- Highly Enantioselective Synthesis of Chiral Cyclopropyl Nucleosides via Catalytic Asymmetric Intermolecular Cyclopropanation. PubMed. Available at: [\[Link\]](#)
- Preparation of Chiral Enantioenriched Densely Substituted Cyclopropyl Azoles, Amines, and Ethers via Formal SN2. MDPI. Available at: [\[Link\]](#)
- Catalytic Asymmetric Intermolecular [3 + 2] Photocycloaddition of Cyclopropylamines with Electron-Deficient Olefins. Organic Letters - ACS Publications. Available at: [\[Link\]](#)
- Machine Learning Prediction of Enantioselectivity in Asymmetric Catalysis from Small, Curated Datasets: Case Studies in Magnesium-Catalyzed Epoxidation and Thia-Michael Addition. ChemRxiv. Available at: [\[Link\]](#)
- (PDF) Machine Learning Prediction of Enantioselectivity in Asymmetric Catalysis from Small, Curated Datasets: Case Studies in Magnesium-Catalyzed Epoxidation and Thia-Michael Addition. ResearchGate. Available at: [\[Link\]](#)

Need Custom Synthesis?

BenchChem offers custom synthesis for rare earth carbides and specific isotopic labeling.

Email: info@benchchem.com or [Request Quote Online](#).

Sources

- [1. pdf.benchchem.com](https://pdf.benchchem.com) [pdf.benchchem.com]
- [2. benchchem.com](https://benchchem.com) [benchchem.com]
- [3. pdf.benchchem.com](https://pdf.benchchem.com) [pdf.benchchem.com]
- [4. pubs.acs.org](https://pubs.acs.org) [pubs.acs.org]
- [5. Diastereoselective and enantioselective cyclopropanation of alkenes catalyzed by cobalt porphyrins - PubMed](#) [pubmed.ncbi.nlm.nih.gov]
- [6. xingweili.snnu.edu.cn](https://xingweili.snnu.edu.cn) [xingweili.snnu.edu.cn]

- To cite this document: BenchChem. [Technical Support Center: Enhancing Enantioselectivity in Chiral Cyclopropylamine Synthesis]. BenchChem, [2026]. [Online PDF]. Available at: [<https://www.benchchem.com/product/b11923970/docs#technical-support-center-enhancing-enantioselectivity-in-chiral-cyclopropylamine-synthesis>]

Disclaimer & Data Validity:

The information provided in this document is for Research Use Only (RUO) and is strictly not intended for diagnostic or therapeutic procedures. While BenchChem strives to provide accurate protocols, we make no warranties, express or implied, regarding the fitness of this product for every specific experimental setup.

Technical Support: The protocols provided are for reference purposes. Unsure if this reagent suits your experiment?

Need Industrial/Bulk Grade? [Request Custom Synthesis Quote](#)

BenchChem

Our mission is to be the trusted global source of essential and advanced chemicals, empowering scientists and researchers to drive progress in science and industry.

Contact

Address: 3281 E Guasti Rd
Ontario, CA 91761, United States
Phone: (601) 213-4426
Email: info@benchchem.com

[Contact our Ph.D. Support Team for a compatibility check](#)