

Application Notes and Protocols: Microwave-Assisted Synthesis of 2-Amino-7-Hydroxyquinoline Derivatives

Author: BenchChem Technical Support Team. **Date:** April 2026

Compound of Interest

Compound Name: 2-Aminoquinolin-7-ol

Cat. No.: B11921968

[Get Quote](#)

Introduction

For researchers, scientists, and professionals in drug development, the synthesis of quinoline derivatives is a critical process in the discovery of new therapeutic agents.[1] The quinoline scaffold is a prominent feature in a wide array of FDA-approved drugs and clinical candidates, demonstrating a broad spectrum of pharmacological activities, including anticancer, antimalarial, antibacterial, and anti-inflammatory properties.[1][2] Specifically, 2-amino-7-hydroxyquinoline derivatives are of significant interest due to their potential as kinase inhibitors and fluorescent probes.

Microwave-assisted organic synthesis (MAOS) has revolutionized this field by offering substantial improvements over classical synthetic methods.[1] This technology provides significant advantages, including drastically reduced reaction times, higher yields, and improved product purity.[1][3] The principles of green chemistry are also well-served by MAOS, which often allows for solvent-free reactions and reduced energy consumption.[4][5][6] This document provides detailed protocols for the microwave-assisted synthesis of 2-amino-7-hydroxyquinoline derivatives, focusing on the underlying principles and practical execution for drug discovery and development applications.

The Power of Microwave-Assisted Synthesis: A Paradigm Shift

Conventional heating methods rely on thermal conduction, where heat is transferred from an external source through the vessel walls to the reaction mixture. This process is often slow and can lead to uneven heating, resulting in longer reaction times and the formation of byproducts. [3] In contrast, microwave-assisted synthesis utilizes the ability of polar molecules (dipolar polarization) and ions (ionic conduction) within the reaction mixture to generate heat directly and volumetrically. [3][4] This direct energy transfer leads to rapid and uniform heating, which dramatically accelerates reaction rates. [4][5][6]

Key Advantages of MAOS:

- **Accelerated Reaction Rates:** Reactions that take hours or even days using conventional heating can often be completed in minutes with microwave irradiation. [1][6]
- **Higher Yields and Purity:** The rapid and uniform heating minimizes the formation of side products, leading to cleaner reactions and higher isolated yields. [3][5]
- **Energy Efficiency:** By directly heating the reactants, microwave synthesis is a more energy-efficient process compared to conventional methods. [5][6]
- **Alignment with Green Chemistry:** MAOS often allows for the use of less hazardous solvents or even solvent-free conditions, reducing the environmental impact of chemical synthesis. [4][5]

Synthesis of 2-Amino-7-Hydroxyquinoline Derivatives: The Friedländer Annulation

A prominent and versatile method for synthesizing quinoline derivatives is the Friedländer annulation. This reaction involves the condensation of a 2-aminoaryl aldehyde or ketone with a compound containing an α -methylene group. [1] Microwave irradiation has been shown to significantly enhance the efficiency of this reaction. [1][7][8]

General Reaction Scheme:

The synthesis of a 2-amino-7-hydroxyquinoline derivative via a microwave-assisted Friedländer reaction can be generalized as follows:

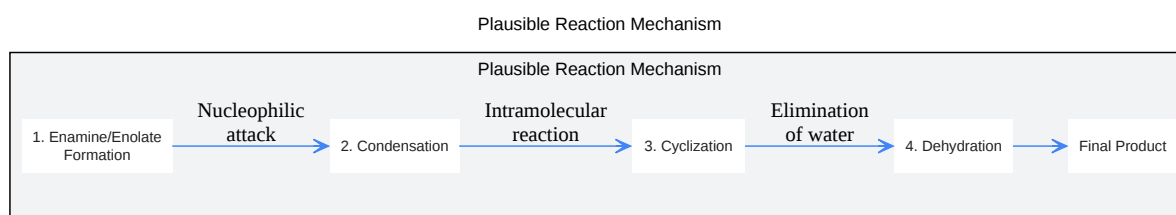
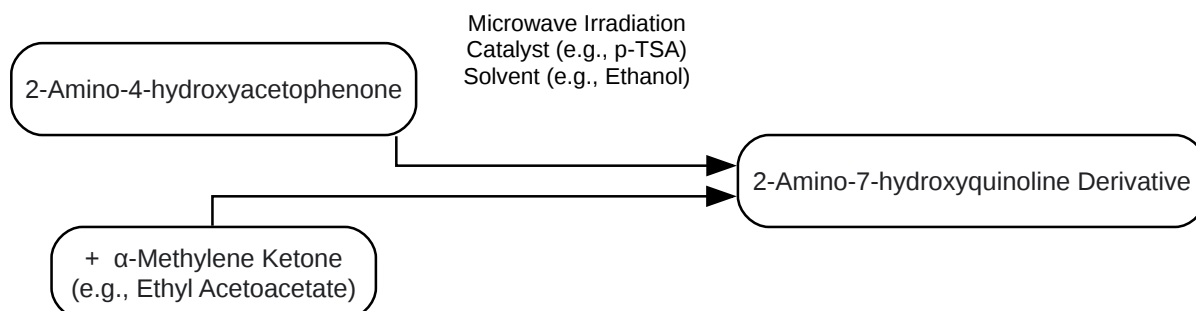

[Click to download full resolution via product page](#)

Caption: Simplified mechanistic steps in the Friedländer annulation.

Experimental Protocols

Protocol 1: Microwave-Assisted Synthesis of Ethyl 2-amino-7-hydroxy-4-methylquinoline-3-carboxylate

This protocol details the synthesis of a specific 2-amino-7-hydroxyquinoline derivative using a dedicated scientific microwave reactor.

Materials:

- 2-Amino-4-hydroxyacetophenone (1.0 mmol)
- Ethyl acetoacetate (1.2 mmol)

- p-Toluenesulfonic acid (p-TSA) (catalytic amount)
- Ethanol (5 mL)
- 10 mL microwave process vial with a magnetic stirrer

Instrumentation:

- Scientific Microwave Reactor (e.g., CEM Discover, Biotage Initiator)

Procedure:

- To a 10 mL microwave process vial, add 2-amino-4-hydroxyacetophenone (1.0 mmol), ethyl acetoacetate (1.2 mmol), and a catalytic amount of p-toluenesulfonic acid.
- Add ethanol (5 mL) to the vial and a magnetic stirrer.
- Seal the vial and place it in the microwave reactor.
- Set the reaction parameters:
 - Temperature: 120 °C
 - Time: 10 minutes
 - Power: 100-200 W (adjust to maintain the target temperature)
- After the reaction is complete, allow the vial to cool to room temperature.
- Pour the reaction mixture into ice-cold water.
- Collect the resulting precipitate by filtration.
- Wash the precipitate with cold water and dry it under a vacuum.
- Purify the crude product by recrystallization from ethanol or by column chromatography on silica gel.

Data Presentation: Comparison of Conventional vs. Microwave-Assisted Synthesis

The advantages of microwave-assisted synthesis are clearly demonstrated when comparing reaction parameters and outcomes with conventional heating methods.

Parameter	Conventional Heating	Microwave-Assisted Synthesis	Reference
Reaction Time	3 hours to overnight	3-4 minutes	[9]
Temperature	Reflux	80-160 °C	[1][7][9]
Yield	Moderate (e.g., 34%)	Good to Excellent (e.g., 72-95%)	[1][10][11]
Energy Consumption	High	Low	[5][6]
Solvent Usage	Often requires larger volumes	Can be performed with less solvent or solvent-free	[5][12]

Experimental Workflow Visualization

The overall workflow for the microwave-assisted synthesis and characterization of 2-amino-7-hydroxyquinoline derivatives can be visualized as follows:

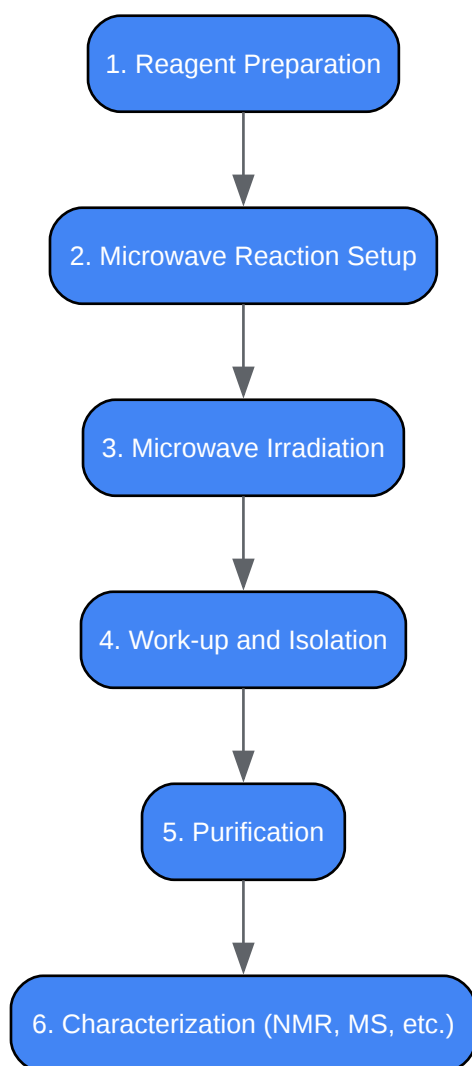

[Click to download full resolution via product page](#)

Caption: General experimental workflow for microwave-assisted synthesis. [13]

Troubleshooting and Optimization

While microwave-assisted synthesis is generally robust, some common issues may arise.

Problem	Possible Cause	Solution	Reference
Low Yield	Incomplete reaction	Increase reaction time or temperature. Ensure efficient stirring.	[13]
Decomposition of starting materials or product	Lower the reaction temperature. Use a solvent with a higher boiling point to maintain pressure.	[13]	
Formation of Byproducts	Non-selective heating	Use a more polar solvent for better microwave absorption and more uniform heating. Optimize the catalyst loading.	[13]
Poor Reproducibility	Inconsistent microwave field	Ensure the reaction vial is placed in the same position in the microwave cavity for each run.	[13]
Variations in starting material quality	Use reagents and solvents of high purity.	[13]	

Conclusion

Microwave-assisted synthesis represents a powerful and efficient platform for the rapid generation of 2-amino-7-hydroxyquinoline derivatives. By significantly reducing reaction times and improving yields, this technology accelerates the drug discovery process, enabling researchers to quickly build and screen libraries of novel compounds. The adherence to green chemistry principles further enhances the appeal of MAOS as a sustainable and environmentally conscious synthetic methodology. The protocols and guidelines presented in

this document are intended to provide a solid foundation for researchers to successfully implement this transformative technology in their laboratories.

References

- Microwave-Assisted Organic Synthesis: An Eco-Friendly Method of Green Chemistry. MDPI.
- Microwaves in Organic Synthetic Chemistry- A Greener Approach to Environmental Protection: An Overview.
- THE ROLE OF MICROWAVE -ASSISTED SYNTHESIS IN ORGANIC CHEMISTRY. (PDF)
- Recent developments on microwave-assisted organic synthesis of nitrogen- and oxygen-containing preferred heterocyclic scaffolds. RSC Publishing.
- Microwave-assisted Synthesis of Quinolines.
- MICROWAVE ASSISTED ORGANIC SYNTHESIS: A GREEN CHEMISTRY APPROACH. IJNRD.
- Impact of Microwaves on Organic Synthesis and Strategies toward Flow Processes and Scaling Up.
- Microwave-Assisted Synthesis of Quinoline Derivatives: Application Notes and Protocols for Researchers. Benchchem.
- Technical Support Center: Microwave-Assisted Synthesis of Quinoline Deriv
- Rapid and Efficient Microwave-Assisted Friedländer Quinoline Synthesis. PubMed.
- Rapid and Efficient Microwave-Assisted Friedländer Quinoline Synthesis. PMC.
- Microwave-enhanced Friedländer synthesis for the rapid assembly of halogenated quinolines with antibacterial and biofilm eradication activities against drug resistant and tolerant bacteria. MedChemComm (RSC Publishing).
- Efficient microwave-assisted synthesis of quinolines and dihydroquinolines under solvent-free conditions. R Discovery.
- Recent developments on microwave-assisted organic synthesis of nitrogen- and oxygen-containing preferred heterocyclic scaffolds. PMC.

Need Custom Synthesis?

BenchChem offers custom synthesis for rare earth carbides and specific isotopic labeling.

Email: info@benchchem.com or [Request Quote Online](#).

Sources

- 1. pdf.benchchem.com [pdf.benchchem.com]

- [2. researchgate.net \[researchgate.net\]](#)
- [3. ijnrd.org \[ijnrd.org\]](#)
- [4. mdpi.com \[mdpi.com\]](#)
- [5. ajgreenchem.com \[ajgreenchem.com\]](#)
- [6. researchgate.net \[researchgate.net\]](#)
- [7. Rapid and Efficient Microwave-Assisted Friedländer Quinoline Synthesis - PubMed \[pubmed.ncbi.nlm.nih.gov\]](#)
- [8. Rapid and Efficient Microwave-Assisted Friedländer Quinoline Synthesis - PMC \[pmc.ncbi.nlm.nih.gov\]](#)
- [9. Recent developments on microwave-assisted organic synthesis of nitrogen- and oxygen-containing preferred heterocyclic scaffolds - RSC Advances \(RSC Publishing\) DOI:10.1039/D3RA05986C \[pubs.rsc.org\]](#)
- [10. Microwave-enhanced Friedländer synthesis for the rapid assembly of halogenated quinolines with antibacterial and biofilm eradication activities against drug resistant and tolerant bacteria - MedChemComm \(RSC Publishing\) \[pubs.rsc.org\]](#)
- [11. Recent developments on microwave-assisted organic synthesis of nitrogen- and oxygen-containing preferred heterocyclic scaffolds - PMC \[pmc.ncbi.nlm.nih.gov\]](#)
- [12. discovery.researcher.life \[discovery.researcher.life\]](#)
- [13. pdf.benchchem.com \[pdf.benchchem.com\]](#)
- To cite this document: BenchChem. [Application Notes and Protocols: Microwave-Assisted Synthesis of 2-Amino-7-Hydroxyquinoline Derivatives]. BenchChem, [2026]. [Online PDF]. Available at: [<https://www.benchchem.com/product/b11921968/docs#application-notes-and-protocols-microwave-assisted-synthesis-of-2-amino-7-hydroxyquinoline-derivatives>]

Disclaimer & Data Validity:

The information provided in this document is for Research Use Only (RUO) and is strictly not intended for diagnostic or therapeutic procedures. While BenchChem strives to provide accurate protocols, we make no warranties, express or implied, regarding the fitness of this product for every specific experimental setup.

Technical Support: The protocols provided are for reference purposes. Unsure if this reagent suits your experiment?

Need Industrial/Bulk Grade? [Request Custom Synthesis Quote](#)

BenchChem

Our mission is to be the trusted global source of essential and advanced chemicals, empowering scientists and researchers to drive progress in science and industry.

Contact

Address: 3281 E Guasti Rd
Ontario, CA 91761, United States
Phone: (601) 213-4426
Email: info@benchchem.com

[Contact our Ph.D. Support Team for a compatibility check](#)