

Technical Monograph: 2-Chloro-4-methoxypyrimidin-5-ol

Author: BenchChem Technical Support Team. **Date:** April 2026

Compound of Interest

Compound Name: 2-Chloro-4-methoxypyrimidin-5-ol

Cat. No.: B11920148

[Get Quote](#)

CAS Number: 2250240-81-2 Synonyms: 2-Chloro-5-hydroxy-4-methoxypyrimidine; 4-Methoxy-2-chloropyrimidin-5-ol Molecular Formula: C₅H₅ClN₂O₂ Molecular Weight: 160.56 g/mol

Executive Summary

2-Chloro-4-methoxypyrimidin-5-ol is a highly specialized heterocyclic building block used primarily in the synthesis of pharmaceutical agents, particularly kinase inhibitors and antagonists for G-protein coupled receptors (GPCRs).[1] Its structural uniqueness lies in the trifunctional nature of the pyrimidine ring:

- **C2-Chlorine:** An electrophilic handle for nucleophilic aromatic substitution (S_NAr) or palladium-catalyzed cross-couplings (Suzuki-Miyaura, Buchwald-Hartwig).
- **C4-Methoxy:** An electron-donating group that modulates the ring's electronics, often serving as a permanent substituent or a latent leaving group under harsh conditions.
- **C5-Hydroxyl:** A versatile nucleophile for etherification or a hydrogen-bonding motif critical for ligand-protein interactions.

This guide details the synthesis, reactivity profile, and handling protocols for this compound, distinguishing it from its common analog, 2-chloro-4-methoxypyrimidine (CAS 22536-63-6), which lacks the critical 5-hydroxyl functionality.

Physicochemical Profile

Property	Value	Notes
Appearance	Off-white to pale yellow solid	Hygroscopic; store under inert gas.
Melting Point	142–145 °C (dec.)	Decomposition observed at elevated temperatures.[2]
Solubility	DMSO, DMF, Methanol	Sparingly soluble in non-polar solvents (Hexane, DCM).
pKa (Calculated)	~6.5 (5-OH)	Acidic hydroxyl due to electron-deficient pyrimidine ring.
LogP	~0.8	Moderate lipophilicity, suitable for drug-like scaffolds.
H-Bond Donors	1	The C5-OH group.
H-Bond Acceptors	4	N1, N3, O(Methoxy), O(Hydroxyl).

Synthesis & Manufacturing

The synthesis of **2-chloro-4-methoxypyrimidin-5-ol** requires precise regiochemical control to distinguish between the C2 and C4 positions. The most robust industrial route proceeds from 5-hydroxyuracil (Isobarbituric acid).

Synthetic Route: The 5-Hydroxyuracil Pathway

- Chlorination: 5-Hydroxyuracil is treated with phosphorus oxychloride (POCl₃) and a tertiary amine base (e.g., N,N-dimethylaniline) to yield 2,4-dichloro-5-hydroxypyrimidine. Note: The 5-OH may be transiently protected or left free depending on the exact conditions; POCl₃ can form a phosphorodichloridate intermediate at the oxygen, which hydrolyzes during workup.

- Regioselective Methoxylation: The 2,4-dichloro intermediate undergoes nucleophilic aromatic substitution with sodium methoxide (NaOMe).
 - Regioselectivity Rule: In 2,4-dichloropyrimidines, the C4 position is significantly more electrophilic than C2 due to the para-like relationship with N1 and the absence of lone-pair repulsion found at C2 (flanked by two nitrogens).
 - Condition Control: Stoichiometric control (2.0–2.1 equivalents of NaOMe) is critical. The first equivalent deprotonates the C5-OH; the second equivalent displaces the C4-Cl.

Detailed Protocol (Lab Scale)

- Step 1: Chlorination[3][4][5][6]
 - Suspend 5-hydroxyuracil (10.0 g) in POCl₃ (50 mL). Add N,N-dimethylaniline (5 mL) dropwise.
 - Reflux for 4 hours until the solution is clear.
 - Concentrate under reduced pressure to remove excess POCl₃.
 - Pour residue onto crushed ice/water carefully (Exothermic!). Extract with Ethyl Acetate.[7]
 - Yields 2,4-dichloro-5-hydroxypyrimidine.[4][5][8]
- Step 2: Methoxylation
 - Dissolve 2,4-dichloro-5-hydroxypyrimidine (5.0 g) in anhydrous Methanol (50 mL) at 0 °C.
 - Add Sodium Methoxide (2.1 eq, 0.5 M in MeOH) dropwise over 30 minutes.
 - Stir at 0–5 °C for 2 hours. Monitor by TLC/LCMS.
 - Quench: Acidify with 1M HCl to pH 4–5.
 - Isolation: Remove MeOH in vacuo. Extract aqueous residue with Ethyl Acetate.[7] Wash with brine, dry over Na₂SO₄. [3]

- Purification: Recrystallization from EtOAc/Hexanes or column chromatography (DCM/MeOH).

Reactivity & Functionalization (The "Warhead" Strategy)

The compound serves as a trifunctional scaffold. The reactivity order is generally C5-OH (Nucleophile) > C2-Cl (Electrophile) >> C4-OMe (Stable).

Structural Reactivity Map (Graphviz)

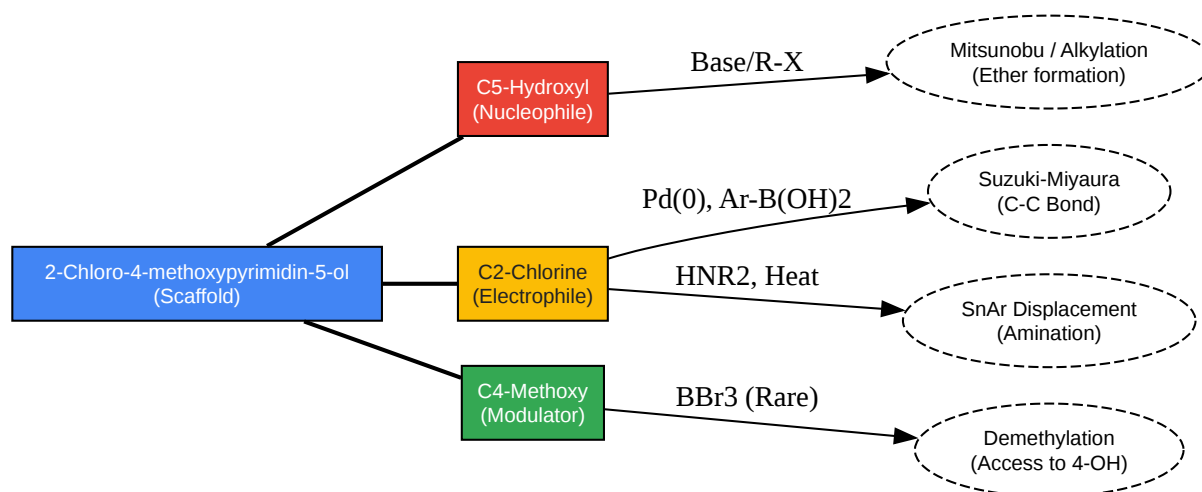

[Click to download full resolution via product page](#)

Caption: Functionalization logic for **2-Chloro-4-methoxypyrimidin-5-ol**. The C5-OH is typically derivatized first to prevent interference with Pd-catalysis at C2.

Strategic Workflow

- Protection/Functionalization of C5-OH:
 - The acidic phenol-like OH (pKa ~6.5) can poison Palladium catalysts. It is standard practice to alkylate this position first (e.g., using alkyl halides/ K_2CO_3 or Mitsunobu conditions) to install the desired side chain.

- C2-Diversification:
 - Once the C5-position is capped, the C2-chlorine is an excellent handle for Suzuki couplings to attach aryl/heteroaryl groups, or S_NAr reactions with amines to create aminopyrimidine cores common in kinase inhibitors (e.g., JAK, EGFR inhibitors).

Applications in Drug Discovery[9]

This scaffold is particularly relevant for Fragment-Based Drug Design (FBDD).

- Kinase Inhibition: The pyrimidine N1 and C2-amino (post-substitution) often form the "hinge-binding" motif in kinase active sites. The C5-substituent projects into the ribose binding pocket or solvent-exposed region, allowing for solubility-enhancing modifications.
- GPCR Ligands: The 4-methoxy group provides a specific steric and electronic profile that can induce conformational locking in GPCR ligands.
- Late-Stage Diversification: As noted in recent methodologies (e.g., RWTH Aachen dissertation), the mesylate derivative of this alcohol allows for late-stage introduction of amines or other nucleophiles.

Handling & Safety Information

Signal Word:WARNING

Hazard Class	H-Code	Statement
Skin Irritation	H315	Causes skin irritation.
Eye Irritation	H319	Causes serious eye irritation. [9]
STOT-SE	H335	May cause respiratory irritation.

Storage Protocol:

- Temperature: 2–8 °C (Refrigerate).

- Atmosphere: Inert gas (Argon/Nitrogen). The compound is hygroscopic and phenols can oxidize over time.
- Container: Amber glass to prevent light-induced degradation.

References

- RWTH Aachen University. (2019). Dissertation: Development of Novel Reagents for Late-Stage Functionalization. Retrieved from
- ChemSrc. (2025).[1] **2-Chloro-4-methoxypyrimidin-5-ol** CAS 2250240-81-2 Entry.[1] Retrieved from
- PubChem. (2025).[9] 2,4-Dichloro-5-methoxypyrimidine (Precursor/Analog Analysis). Retrieved from
- Organic Syntheses. (1951). Synthesis of 4-Methyl-6-hydroxypyrimidine (General Pyrimidine Methodologies). Coll. Vol. 3, p. 581. Retrieved from

Need Custom Synthesis?

BenchChem offers custom synthesis for rare earth carbides and specific isotopic labeling.

Email: info@benchchem.com or [Request Quote Online](#).

Sources

- 1. 707-18-6_CAS号:707-18-6_Tetrahydro-5-oxo-2-(trifluoromethyl)-2-furancarboxamide - 化源网 [m.chemsrc.com]
- 2. Organic Syntheses Procedure [orgsyn.org]
- 3. CN103554036B - The preparation method of a kind of 2-chloro-4-substituted pyrimidines compounds - Google Patents [patents.google.com]
- 4. Preparation method of 2,4-dichloro-5-methoxypyrimidine - Eureka | Patsnap [eureka.patsnap.com]
- 5. CN101486684B - Preparation of 2,4-dichloro-5-methoxy pyrimidine - Google Patents [patents.google.com]

- [6. CN101486684B - Preparation of 2,4-dichloro-5-methoxy pyrimidine - Google Patents \[patents.google.com\]](#)
- [7. guidechem.com \[guidechem.com\]](#)
- [8. 2,4-Dichloro-5-methoxypyrimidine synthesis - chemicalbook \[chemicalbook.com\]](#)
- [9. 2-Chloro-5-methylpyrimidin-4-ol | C5H5ClN2O | CID 49783283 - PubChem \[pubchem.ncbi.nlm.nih.gov\]](#)
- To cite this document: BenchChem. [Technical Monograph: 2-Chloro-4-methoxypyrimidin-5-ol]. BenchChem, [2026]. [Online PDF]. Available at: [\[https://www.benchchem.com/product/b11920148/docs#technical-monograph-2-chloro-4-methoxypyrimidin-5-ol\]](https://www.benchchem.com/product/b11920148/docs#technical-monograph-2-chloro-4-methoxypyrimidin-5-ol)

Disclaimer & Data Validity:

The information provided in this document is for Research Use Only (RUO) and is strictly not intended for diagnostic or therapeutic procedures. While BenchChem strives to provide accurate protocols, we make no warranties, express or implied, regarding the fitness of this product for every specific experimental setup.

Technical Support: The protocols provided are for reference purposes. Unsure if this reagent suits your experiment?

Need Industrial/Bulk Grade? [Request Custom Synthesis Quote](#)

BenchChem

Our mission is to be the trusted global source of essential and advanced chemicals, empowering scientists and researchers to drive progress in science and industry.

Contact

Address: 3281 E Guasti Rd
Ontario, CA 91761, United States
Phone: (601) 213-4426
Email: info@benchchem.com

Contact our Ph.D. Support Team for a compatibility check