

troubleshooting inconsistent results in KA2237 experiments

Author: BenchChem Technical Support Team. **Date:** April 2026

Compound of Interest

Compound Name: KA2237
Cat. No.: B1192992

[Get Quote](#)

Technical Support Center: KA2237 Experiments

This technical support center provides troubleshooting guidance and frequently asked questions (FAQs) for researchers and drug development professionals working with **KA2237**, a dual inhibitor of PI3K-p110 β and PI3K-p110 δ .

Troubleshooting Guides

Inconsistent IC50 Values in Cell Viability Assays

Problem: You are observing significant variability in the half-maximal inhibitory concentration (IC50) of **KA2237** in your cell viability assays (e.g., MTT, CellTiter-Glo®).

Possible Causes and Solutions:

Cause	Recommended Solution
Cell Culture Conditions	Culture conditions can significantly impact the cellular response to PI3K inhibitors. Maintain consistent cell passage numbers, seeding densities, and media formulations. Ensure cells are healthy and in the logarithmic growth phase before treatment.
Serum Concentration	Growth factors in fetal bovine serum (FBS) can activate the PI3K pathway, competing with the inhibitory effect of KA2237. If appropriate for your cell line, consider reducing the serum concentration or serum-starving the cells prior to and during treatment.
Treatment Duration	The optimal treatment duration can be cell-line specific. If you are not seeing a potent effect, consider extending the incubation time with KA2237 (e.g., from 48 to 72 or 96 hours).[1]
Compound Stability	Ensure your KA2237 stock solution is properly stored according to the manufacturer's instructions to prevent degradation. Prepare fresh dilutions for each experiment.
Assay Interference	Some assay reagents can interfere with the compound or be affected by cell number. Ensure you are using the appropriate assay for your cell line and experimental conditions and include proper controls.

Weak or No Inhibition of p-AKT in Western Blot

Problem: After treating cells with **KA2237**, you do not observe a significant decrease in the phosphorylation of AKT (a downstream target of PI3K) via Western blot.

Possible Causes and Solutions:

Cause	Recommended Solution
Suboptimal Treatment Time	Inhibition of AKT phosphorylation can be rapid and transient.[2] Perform a time-course experiment (e.g., 0.5, 1, 2, 4, 8, 24 hours) to determine the optimal time point for observing maximal p-AKT inhibition in your specific cell line.
Basal Pathway Activity	The basal level of PI3K pathway activity may be low in your cell line under standard culture conditions. Consider stimulating the pathway with a growth factor (e.g., IGF-1, FGF) for a short period before cell lysis to increase the dynamic range for observing inhibition.[3]
Feedback Loop Activation	Inhibition of the PI3K pathway can sometimes lead to the activation of compensatory feedback loops, which can reactivate downstream signaling.[4] Shorter treatment times are often better for observing direct inhibitory effects.
Antibody Quality	The quality of your primary antibodies against p-AKT and total AKT is crucial. Ensure they are validated for your application and used at the recommended dilution. Consider using a positive control lysate to confirm antibody performance.
Lysis Buffer Composition	It is critical to use a lysis buffer containing phosphatase inhibitors to preserve the phosphorylation status of your proteins of interest.[5]

Frequently Asked Questions (FAQs)

Q1: What is the mechanism of action of **KA2237**?

A1: **KA2237** is an orally active, potent, and dual-selective small molecule inhibitor of the p110 β (beta) and p110 δ (delta) isoforms of phosphoinositide 3-kinase (PI3K).[6][7][8] By inhibiting these isoforms, **KA2237** disrupts the PI3K/AKT/mTOR signaling pathway, which is crucial for cell growth, proliferation, and survival in many types of cancer, particularly B-cell malignancies. [6][9]

Q2: What are the known off-target effects of **KA2237**?

A2: While **KA2237** is designed to be selective for PI3K-p110 β and p110 δ , like all kinase inhibitors, it may have off-target effects. In clinical studies, observed side effects included rash, pneumonia, transaminitis, and pneumonitis.[6][9] In a preclinical setting, it is important to consider that high concentrations of the inhibitor may lead to off-target kinase inhibition. If you suspect off-target effects, consider performing a kinome profiling assay.

Q3: How should I prepare and store **KA2237**?

A3: **KA2237** is typically supplied as a solid. For in vitro experiments, it is common to prepare a concentrated stock solution in a solvent such as dimethyl sulfoxide (DMSO). Aliquot the stock solution into single-use vials to avoid repeated freeze-thaw cycles and store at -20°C or -80°C. For cell-based assays, the final concentration of DMSO should be kept low (typically below 0.1%) to avoid solvent-induced toxicity.

Q4: My cells seem to develop resistance to **KA2237** over time. What could be the reason?

A4: Acquired resistance to PI3K inhibitors is a known phenomenon.[4] Several mechanisms can contribute to this, including:

- Activation of bypass signaling pathways: Cells may upregulate alternative survival pathways to compensate for the inhibition of PI3K signaling.
- Mutations in the PI3K pathway: Secondary mutations in components of the PI3K pathway can render the inhibitor less effective.
- Feedback loop activation: Chronic inhibition can lead to the sustained activation of feedback mechanisms that reactivate the pathway.[10]

Q5: Can I use **KA2237** in combination with other inhibitors?

A5: Yes, combination therapies are a common strategy to enhance efficacy and overcome resistance. Combining **KA2237** with inhibitors of other signaling pathways (e.g., MAPK, BTK) or with chemotherapeutic agents has shown synergistic effects in some preclinical models.[9] However, it is essential to perform your own synergy studies to determine the optimal combination and dosing schedule for your specific experimental system.

Experimental Protocols

Protocol 1: Cell Viability (IC50 Determination) using CellTiter-Glo®

This protocol describes a method for determining the IC50 of **KA2237** in a cancer cell line using the CellTiter-Glo® Luminescent Cell Viability Assay.

Materials:

- Cancer cell line of interest
- Complete cell culture medium
- **KA2237**
- DMSO
- 96-well white, clear-bottom tissue culture plates
- CellTiter-Glo® Luminescent Cell Viability Assay kit
- Luminometer

Procedure:

- Cell Seeding: Seed cells in a 96-well plate at a predetermined optimal density and allow them to adhere overnight.
- Compound Preparation: Prepare a 2X serial dilution of **KA2237** in complete culture medium. Also, prepare a vehicle control (medium with the same final concentration of DMSO as the highest drug concentration) and a no-cell control (medium only).

- Treatment: Remove the existing medium from the cells and add 100 μ L of the prepared drug dilutions or controls to the appropriate wells.
- Incubation: Incubate the plate for 72 hours at 37°C in a 5% CO₂ incubator.
- Assay:
 - Equilibrate the plate and the CellTiter-Glo® reagent to room temperature.
 - Add 100 μ L of CellTiter-Glo® reagent to each well.
 - Place the plate on an orbital shaker for 2 minutes to induce cell lysis.
 - Incubate at room temperature for 10 minutes to stabilize the luminescent signal.
 - Measure luminescence using a plate reader.
- Data Analysis:
 - Subtract the average background luminescence (no-cell control) from all other measurements.
 - Normalize the data to the vehicle control (set to 100% viability).
 - Plot the normalized data against the log of the **KA2237** concentration and use a non-linear regression model to determine the IC₅₀ value.

Protocol 2: Western Blot for Phospho-AKT (Ser473) Inhibition

This protocol provides a method for assessing the effect of **KA2237** on the phosphorylation of AKT at Serine 473.

Materials:

- Cancer cell line of interest
- Complete cell culture medium

- **KA2237**
- DMSO
- Growth factor (e.g., IGF-1, optional)
- Ice-cold Phosphate-Buffered Saline (PBS)
- RIPA Lysis Buffer supplemented with protease and phosphatase inhibitors
- BCA Protein Assay Kit
- Laemmli sample buffer
- SDS-PAGE gels
- PVDF membrane
- Blocking buffer (e.g., 5% BSA in TBST)
- Primary antibodies: rabbit anti-phospho-AKT (Ser473) and rabbit anti-total AKT
- HRP-conjugated anti-rabbit secondary antibody
- Enhanced Chemiluminescence (ECL) substrate
- Chemiluminescence imaging system

Procedure:

- Cell Treatment:
 - Seed cells in 6-well plates and grow to 70-80% confluency.
 - (Optional) Serum-starve cells for 4-6 hours.
 - Treat cells with the desired concentrations of **KA2237** or vehicle (DMSO) for the determined optimal time (e.g., 2 hours).

- (Optional) 15-30 minutes before the end of the treatment, stimulate cells with a growth factor.
- Cell Lysis:
 - Place plates on ice and wash cells twice with ice-cold PBS.
 - Add ice-cold lysis buffer, scrape the cells, and transfer the lysate to a microcentrifuge tube.
 - Incubate on ice for 30 minutes, vortexing occasionally.
 - Centrifuge at 14,000 x g for 15 minutes at 4°C. Collect the supernatant.
- Protein Quantification: Determine the protein concentration of each lysate using a BCA assay.
- Sample Preparation and SDS-PAGE:
 - Normalize protein concentrations with lysis buffer.
 - Mix 20-30 µg of protein with Laemmli sample buffer and boil at 95°C for 5 minutes.
 - Load samples onto an SDS-PAGE gel and run until the dye front reaches the bottom.
- Protein Transfer: Transfer the separated proteins to a PVDF membrane.
- Immunoblotting:
 - Block the membrane with 5% BSA in TBST for 1 hour at room temperature.
 - Incubate the membrane with the primary anti-phospho-AKT antibody (diluted in blocking buffer) overnight at 4°C.
 - Wash the membrane three times with TBST for 10 minutes each.
 - Incubate with the HRP-conjugated secondary antibody for 1 hour at room temperature.
 - Wash the membrane three times with TBST for 10 minutes each.

- Detection and Analysis:
 - Incubate the membrane with ECL substrate.
 - Capture the chemiluminescent signal using an imaging system.
 - Strip the membrane and re-probe for total AKT and a loading control (e.g., GAPDH).
 - Quantify band intensities and normalize the p-AKT signal to total AKT.

Visualizations

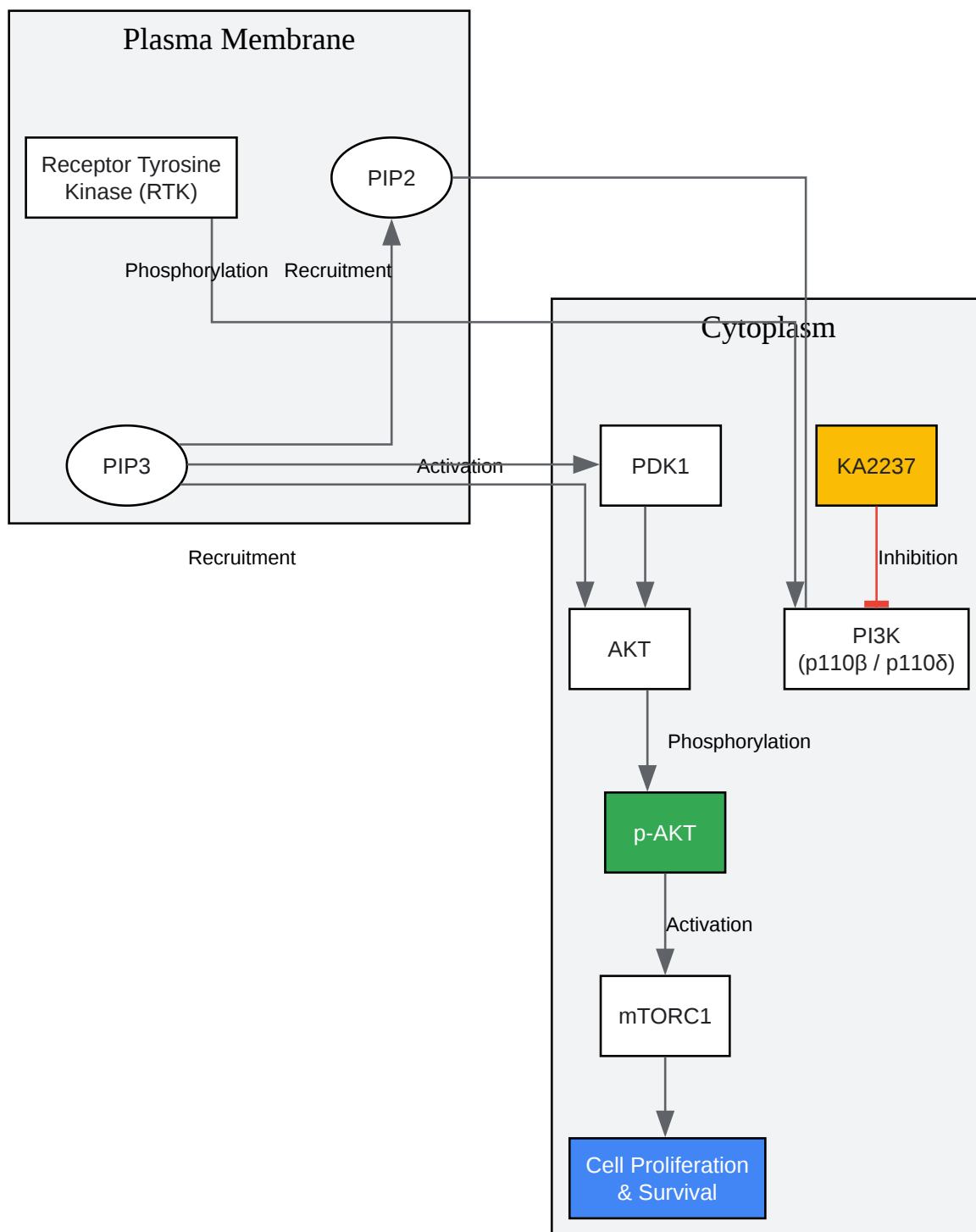

[Click to download full resolution via product page](#)

Caption: PI3K signaling pathway and the inhibitory action of **KA2237**.

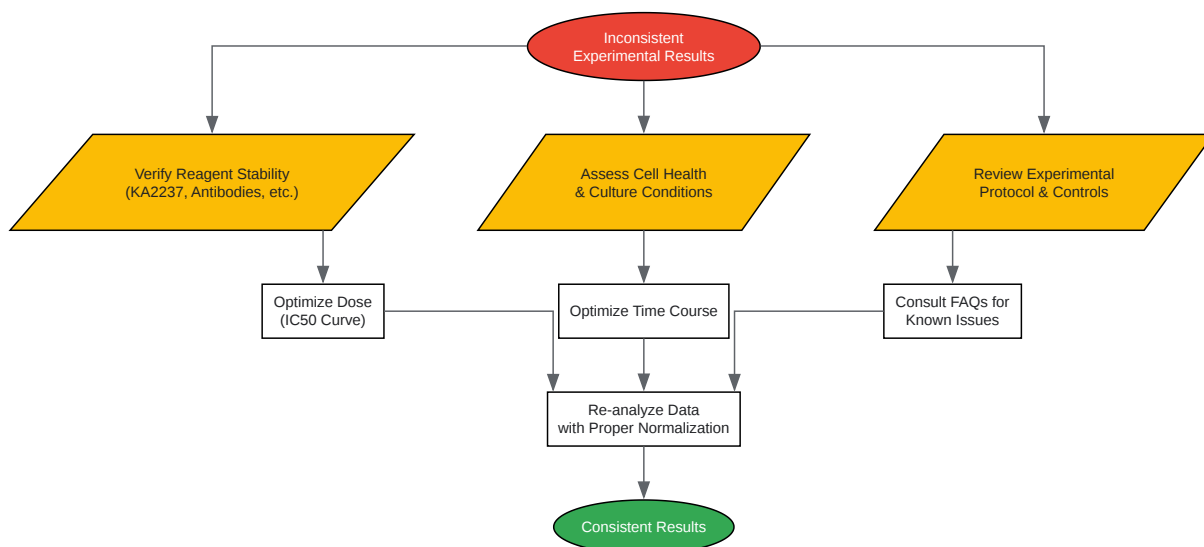

[Click to download full resolution via product page](#)

Caption: A logical workflow for troubleshooting inconsistent **KA2237** experimental results.

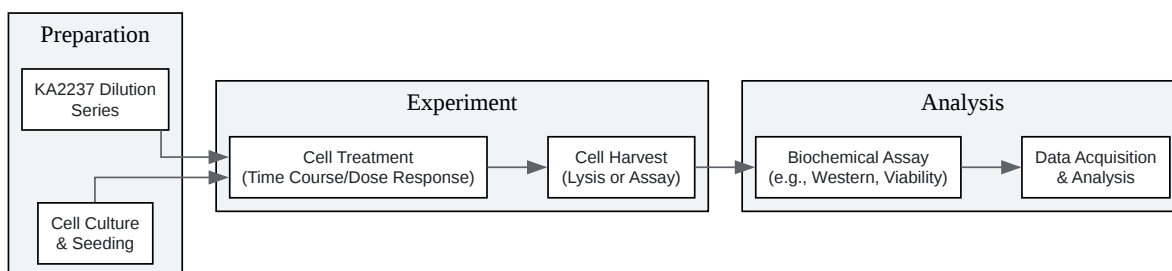

[Click to download full resolution via product page](#)

Caption: A general experimental workflow for evaluating the effects of **KA2237**.

Need Custom Synthesis?

BenchChem offers custom synthesis for rare earth carbides and specific isotopic labeling.

Email: info@benchchem.com or [Request Quote Online](#).

References

- [1. benchchem.com](https://www.benchchem.com) [benchchem.com]
- [2. aacrjournals.org](https://aacrjournals.org) [aacrjournals.org]
- [3. benchchem.com](https://www.benchchem.com) [benchchem.com]
- [4. mdpi.com](https://www.mdpi.com) [mdpi.com]
- [5. benchchem.com](https://www.benchchem.com) [benchchem.com]
- [6. Preclinical and phase I studies of KA2237, a selective and potent inhibitor of PI3K \$\beta/\delta\$ in relapsed refractory B cell lymphoma - PubMed](#) [pubmed.ncbi.nlm.nih.gov]
- [7. europeanpharmaceuticalreview.com](https://www.europeanpharmaceuticalreview.com) [europeanpharmaceuticalreview.com]
- [8. firstwordpharma.com](https://www.firstwordpharma.com) [firstwordpharma.com]
- [9. KA-2237 - Drug Targets, Indications, Patents - Synapse](https://www.synapse.patsnap.com) [synapse.patsnap.com]
- [10. aacrjournals.org](https://aacrjournals.org) [aacrjournals.org]
- To cite this document: BenchChem. [troubleshooting inconsistent results in KA2237 experiments]. BenchChem, [2026]. [Online PDF]. Available at: [https://www.benchchem.com/product/b1192992/docs#troubleshooting-inconsistent-results-in-ka2237-experiments]

Disclaimer & Data Validity:

The information provided in this document is for Research Use Only (RUO) and is strictly not intended for diagnostic or therapeutic procedures. While BenchChem strives to provide accurate protocols, we make no warranties, express or implied, regarding the fitness of this product for every specific experimental setup.

Technical Support: The protocols provided are for reference purposes. Unsure if this reagent suits your experiment?

Need Industrial/Bulk Grade? [Request Custom Synthesis Quote](#)

BenchChem

Our mission is to be the trusted global source of essential and advanced chemicals, empowering scientists and researchers to drive progress in science and industry.

Contact

Address: 3281 E Guasti Rd
Ontario, CA 91761, United States
Phone: (601) 213-4426
Email: info@benchchem.com

[Contact our Ph.D. Support Team for a compatibility check](#)