

GSK-LSD1 Dihydrochloride: Application Notes and Protocols for Cell Culture Experiments

Author: BenchChem Technical Support Team. **Date:** April 2026

Compound of Interest

Compound Name: GSK-LSD1 Dihydrochloride

CAS No.: 1821798-25-7

Cat. No.: B1192839

[Get Quote](#)

For Researchers, Scientists, and Drug Development Professionals

Introduction

GSK-LSD1 Dihydrochloride is a potent, selective, and irreversible inhibitor of Lysine-Specific Demethylase 1 (LSD1), also known as KDM1A.[1][2] LSD1 is a flavin-dependent monoamine oxidase that plays a critical role in transcriptional regulation by demethylating mono- and dimethylated histone H3 at lysine 4 (H3K4me1/2) and lysine 9 (H3K9me1/2).[3][4] Dysregulation of LSD1 activity is implicated in the pathogenesis of various cancers, making it a compelling target for therapeutic intervention.[3] GSK-LSD1 serves as a valuable chemical probe for investigating the biological functions of LSD1 and for assessing its therapeutic potential in preclinical studies.[5]

This document provides detailed application notes and protocols for the use of **GSK-LSD1 Dihydrochloride** in cell culture experiments, aimed at assisting researchers in the fields of oncology, epigenetics, and drug discovery.

Mechanism of Action

GSK-LSD1 acts as an irreversible, mechanism-based inhibitor of LSD1.[5][6] It forms a covalent adduct with the FAD cofactor in the active site of the enzyme, leading to its inactivation.[3] This inhibition of LSD1's demethylase activity results in an increase in global H3K4 and H3K9 methylation levels, subsequently altering gene expression.[4][7] GSK-LSD1 is highly selective for LSD1, with over 1000-fold selectivity against other closely related FAD-utilizing enzymes such as LSD2, MAO-A, and MAO-B.[1][5][6]

Data Presentation

In Vitro Potency and Efficacy

Parameter	Value	Reference
IC50 (Cell-free assay)	16 nM	[1][2][5][6]
Average EC50 (Cancer cell line growth)	< 5 nM	[1][5][6]
Average EC50 (Gene expression changes)	< 5 nM	[1][5]

Cellular Activity in Specific Cancer Cell Lines

Cell Line	Assay Type	Concentration	Incubation Time	Observed Effect	Reference
U2OS	Western Blot (LC3-II formation)	200 μ M	12 h	Induction of autophagy	[1][2]
A549	Western Blot-based CESTA	10 μ M	1 h	Increased stability of cellular LSD1 protein	[1]
MOLM-13	BrdU Cell Proliferation Assay	Titration	6 days	Inhibition of cell proliferation	[7]
THP-1	Clonogenic Assay	10 μ M	Not Specified	~70% inhibition of clonogenic activity	[3]
MV4-11	Clonogenic Assay	10 μ M	Not Specified	~80% inhibition of clonogenic activity	[3]
MCF7	Gene Expression Analysis (PCR)	Not Specified	Not Specified	Upregulation of ERVs and interferon-stimulated genes	[8]
PeTa (Merkel Cell Carcinoma)	Cell Viability Assay	100 nM	6 days	Induction of cell death (Annexin V positive)	[9]

Signaling Pathways Affected by GSK-LSD1

GSK-LSD1-mediated inhibition of LSD1 has been shown to modulate several key oncogenic signaling pathways:

- c-Myc Pathway: Inhibition of LSD1 can lead to the suppression of c-Myc signaling.[10]
- Wnt/ β -catenin Pathway: GSK-LSD1 treatment has been observed to down-regulate the Wnt/ β -catenin signaling pathway.[10]
- YAP/TAZ Pathway: The transcriptional activity of the Hippo pathway effectors YAP and TAZ can be inhibited by GSK-LSD1.[10]
- p53 Pathway: GSK-LSD1 can promote the expression of the tumor suppressor p53.[10]
- Interferon (IFN) Signaling: Inhibition of LSD1 can induce the expression of endogenous retroviral elements (ERVs), leading to the activation of interferon signaling pathways.[8]

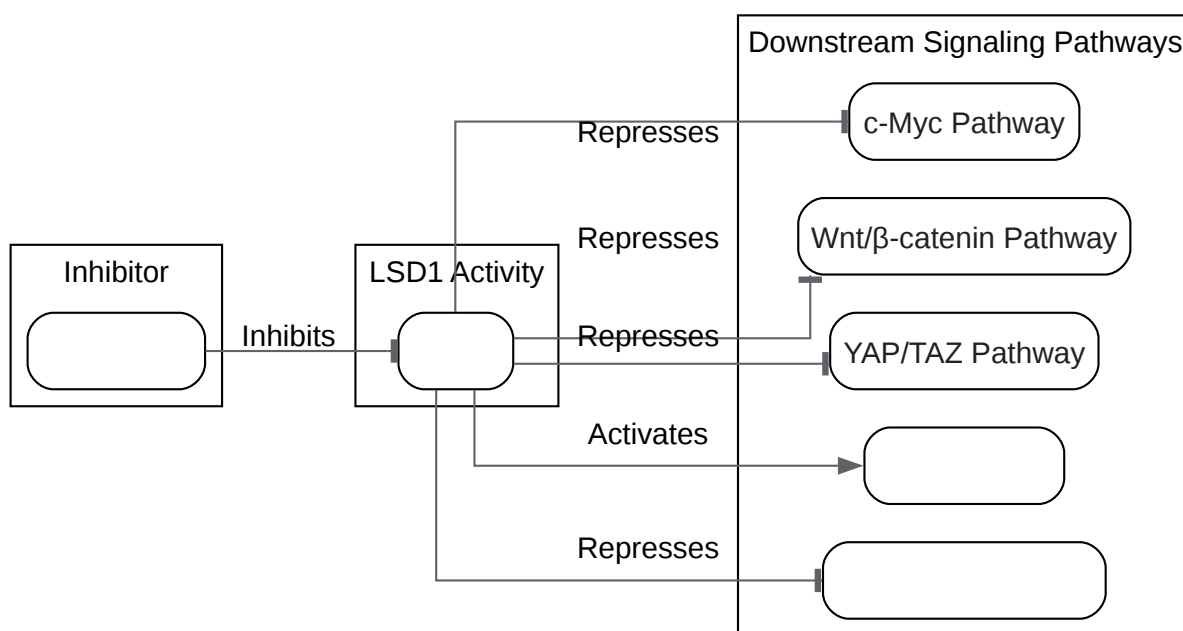

[Click to download full resolution via product page](#)

Caption: GSK-LSD1 inhibits LSD1, modulating key cancer-related signaling pathways.

Experimental Protocols

Cell Proliferation Assay (BrdU Incorporation)

This protocol is adapted for assessing the anti-proliferative effects of GSK-LSD1 on adherent or suspension cancer cell lines.

Materials:

- **GSK-LSD1 Dihydrochloride**
- Appropriate cancer cell line (e.g., MOLM-13)
- Complete cell culture medium
- 96-well cell culture plates
- BrdU Cell Proliferation Assay Kit
- Microplate reader

Procedure:

- **Cell Seeding:** Seed cells in a 96-well plate at a density of 5,000-10,000 cells per well in 100 μ L of complete medium. For suspension cells, use V-bottom plates.
- **Compound Treatment:** Prepare a 2X serial dilution of GSK-LSD1 in complete medium. Add 100 μ L of the diluted compound to the respective wells. Include vehicle control (e.g., DMSO) wells.
- **Incubation:** Incubate the plate for 4-6 days at 37°C in a humidified incubator with 5% CO₂.
- **BrdU Labeling:** Add BrdU labeling solution to each well according to the manufacturer's instructions and incubate for 2-4 hours.
- **Cell Fixation and Detection:** Fix the cells and detect BrdU incorporation using the anti-BrdU antibody and substrate solution provided in the kit.

- Data Acquisition: Measure the absorbance at the appropriate wavelength using a microplate reader.
- Data Analysis: Calculate the percentage of proliferation inhibition relative to the vehicle control and determine the EC50 value.

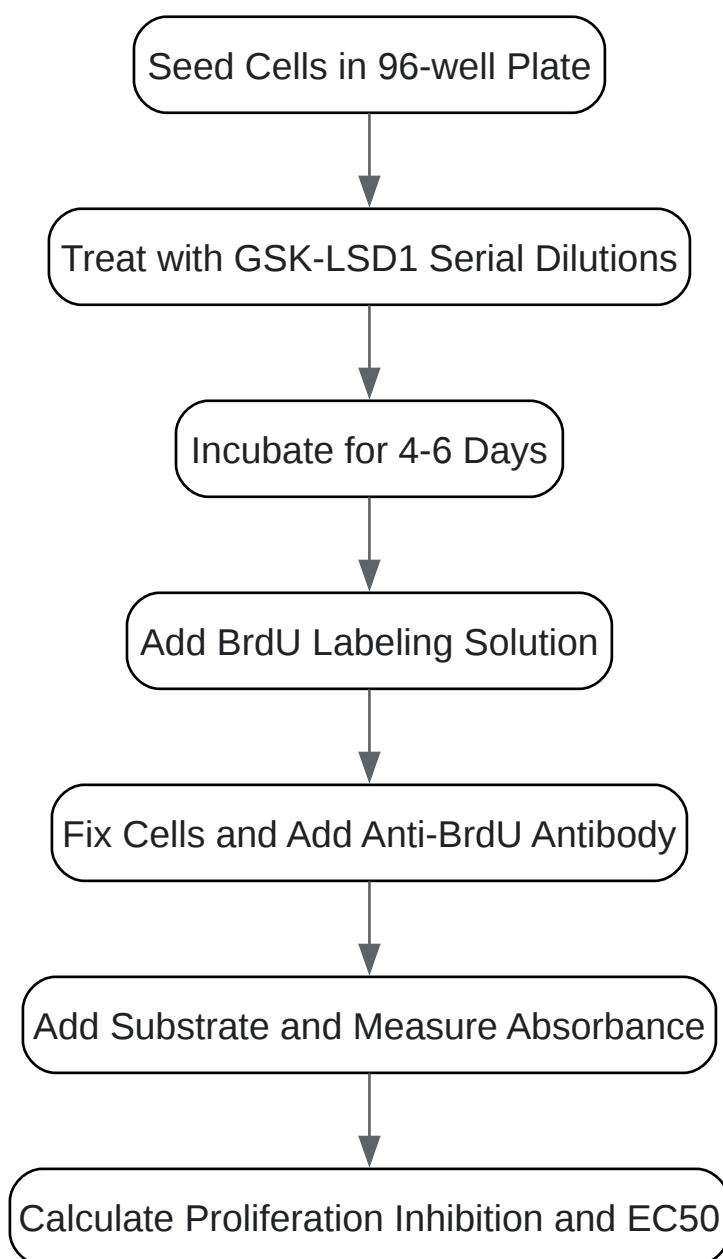

[Click to download full resolution via product page](#)

Caption: Workflow for assessing cell proliferation using a BrdU incorporation assay.

Western Blot Analysis for Histone Methylation

This protocol outlines the procedure for detecting changes in histone H3K4 methylation following GSK-LSD1 treatment.

Materials:

- **GSK-LSD1 Dihydrochloride**
- Cancer cell line of interest (e.g., U2OS)
- 6-well cell culture plates
- RIPA buffer with protease and phosphatase inhibitors
- BCA Protein Assay Kit
- SDS-PAGE gels and running buffer
- PVDF membrane
- Transfer buffer
- Blocking buffer (e.g., 5% non-fat milk or BSA in TBST)
- Primary antibodies (e.g., anti-H3K4me2, anti-Total Histone H3)
- HRP-conjugated secondary antibody
- Chemiluminescent substrate
- Imaging system

Procedure:

- **Cell Treatment:** Seed cells in 6-well plates and allow them to adhere. Treat the cells with the desired concentrations of GSK-LSD1 (e.g., 100 nM - 1 μ M) for 24-48 hours.
- **Cell Lysis:** Wash the cells with ice-cold PBS and lyse them in RIPA buffer.

- **Protein Quantification:** Determine the protein concentration of the lysates using a BCA assay.
- **SDS-PAGE and Transfer:** Load equal amounts of protein onto an SDS-PAGE gel. After electrophoresis, transfer the proteins to a PVDF membrane.
- **Blocking and Antibody Incubation:** Block the membrane with blocking buffer for 1 hour at room temperature. Incubate the membrane with the primary antibody overnight at 4°C.
- **Secondary Antibody and Detection:** Wash the membrane and incubate with the HRP-conjugated secondary antibody for 1 hour at room temperature. Detect the signal using a chemiluminescent substrate and an imaging system.
- **Analysis:** Quantify the band intensities and normalize the H3K4me2 signal to the total Histone H3 signal.

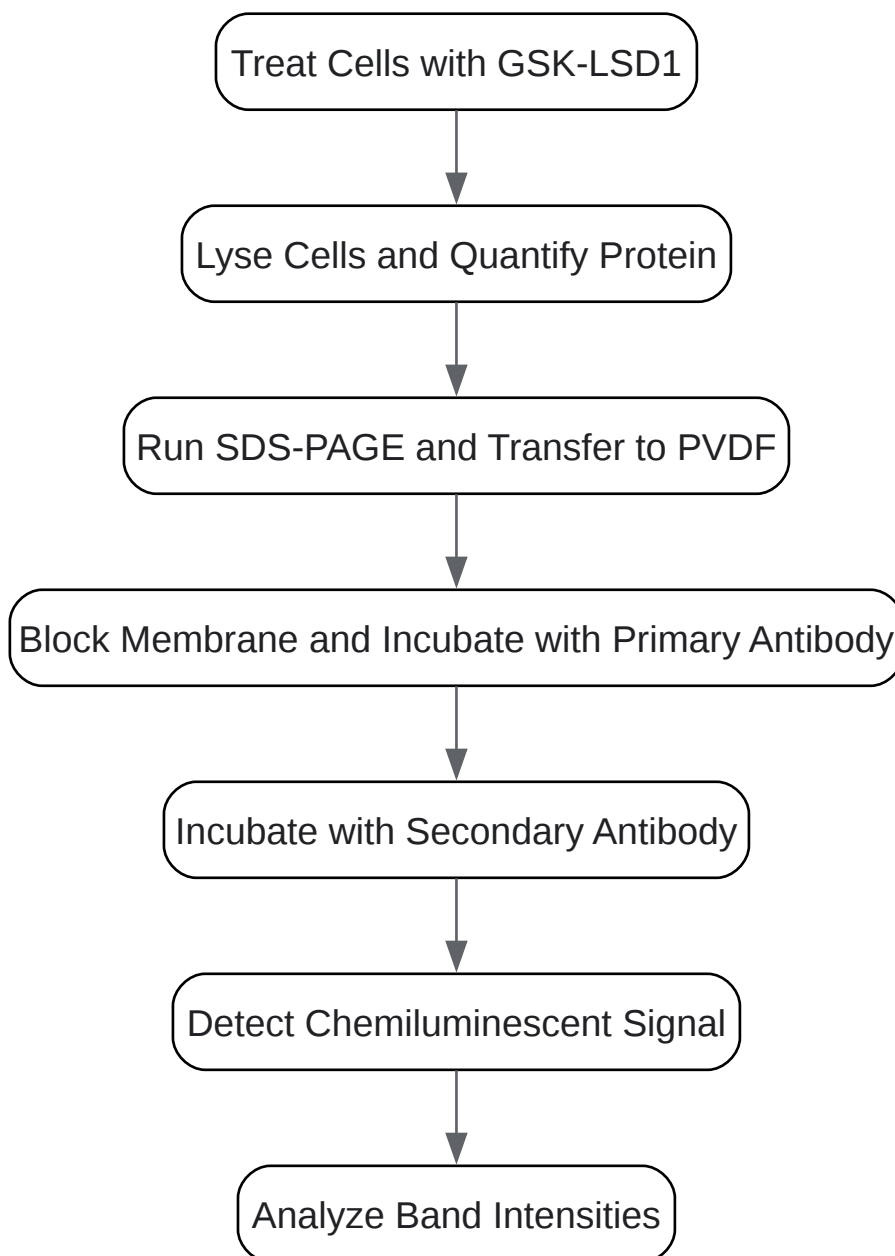

[Click to download full resolution via product page](#)

Caption: Standard workflow for Western blot analysis of histone methylation.

Solubility and Formulation

GSK-LSD1 Dihydrochloride is soluble in water and DMSO.[6] For cell culture experiments, it is recommended to prepare a concentrated stock solution in DMSO (e.g., 10-50 mM) and then dilute it to the final working concentration in the cell culture medium. Ensure the final DMSO

concentration in the culture medium does not exceed 0.1-0.5% to avoid solvent-induced toxicity. A fresh DMSO stock is recommended as moisture can reduce solubility.[1]

Concluding Remarks

GSK-LSD1 Dihydrochloride is a powerful tool for studying the epigenetic regulation mediated by LSD1. The protocols and data presented here provide a foundation for designing and executing robust cell culture experiments to explore its biological effects and therapeutic potential. Researchers should optimize the experimental conditions, including cell line, drug concentration, and incubation time, for their specific research questions.

Need Custom Synthesis?

BenchChem offers custom synthesis for rare earth carbides and specific isotopic labeling.

Email: info@benchchem.com or [Request Quote Online](#).

References

- [1. selleckchem.com](https://www.selleckchem.com) [selleckchem.com]
- [2. medchemexpress.com](https://www.medchemexpress.com) [medchemexpress.com]
- [3. Frontiers | LSD1 inhibitors for cancer treatment: Focus on multi-target agents and compounds in clinical trials](https://www.frontiersin.org) [frontiersin.org]
- [4. axonmedchem.com](https://www.axonmedchem.com) [axonmedchem.com]
- [5. GSK-LSD1 | Structural Genomics Consortium](https://www.thesgc.org) [thesgc.org]
- [6. axonmedchem.com](https://www.axonmedchem.com) [axonmedchem.com]
- [7. Lysine specific demethylase 1 inactivation enhances differentiation and promotes cytotoxic response when combined with all-trans retinoic acid in acute myeloid leukemia across subtypes - PMC](https://pubmed.ncbi.nlm.nih.gov) [pmc.ncbi.nlm.nih.gov]
- [8. LSD1 ablation stimulates anti-tumor immunity and enables checkpoint blockade - PMC](https://pubmed.ncbi.nlm.nih.gov) [pmc.ncbi.nlm.nih.gov]
- [9. embopress.org](https://www.embopress.org) [embopress.org]
- [10. researchgate.net](https://www.researchgate.net) [researchgate.net]

- To cite this document: BenchChem. [GSK-LSD1 Dihydrochloride: Application Notes and Protocols for Cell Culture Experiments]. BenchChem, [2026]. [Online PDF]. Available at: [<https://www.benchchem.com/product/b1192839/docs#gsk-isd1-dihydrochloride-application-notes-and-protocols-for-cell-culture-experiments>]

Disclaimer & Data Validity:

The information provided in this document is for Research Use Only (RUO) and is strictly not intended for diagnostic or therapeutic procedures. While BenchChem strives to provide accurate protocols, we make no warranties, express or implied, regarding the fitness of this product for every specific experimental setup.

Technical Support: The protocols provided are for reference purposes. Unsure if this reagent suits your experiment?

Need Industrial/Bulk Grade? [Request Custom Synthesis Quote](#)

BenchChem

Our mission is to be the trusted global source of essential and advanced chemicals, empowering scientists and researchers to drive progress in science and industry.

Contact

Address: 3281 E Guasti Rd
Ontario, CA 91761, United States
Phone: (601) 213-4426
Email: info@benchchem.com

[Contact our Ph.D. Support Team for a compatibility check](#)