

Application Note: 6-Hydroxy-3-methylindolin-2-one in Kinase Inhibitor Design

Author: BenchChem Technical Support Team. **Date:** April 2026

Compound of Interest

Compound Name: 6-Hydroxy-3-methylindolin-2-one

Cat. No.: B11918152

[Get Quote](#)

Part 1: Strategic Overview & Chemical Biology

The "Privileged" Scaffold Rationale

The oxindole (indolin-2-one) core is a "privileged structure" in medicinal chemistry, serving as the anchor for multiple FDA-approved kinase inhibitors (e.g., Sunitinib, Nintedanib). The specific derivative **6-Hydroxy-3-methylindolin-2-one** offers a unique trifunctional handle for FBDD:

- **The Hinge Binder (Core):** The lactam (NH/C=O) mimics the adenine ring of ATP, forming bidentate hydrogen bonds with the kinase hinge region (e.g., Glu/Met residues).
- **The Solubility Handle (C6-OH):** The hydroxyl group at position 6 is solvent-exposed in many kinase binding modes (e.g., VEGFR2, FGFR). It allows for the attachment of solubilizing tails (morpholines, piperazines) without disrupting the core binding event.
- **The Stereochemical Pivot (C3-Methyl):** Unlike the planar methylene of unsubstituted oxindoles, the C3-methyl group introduces a chiral center (hybridization). This allows for the design of 3,3-disubstituted oxindoles, which lock the ligand into a rigid conformation, reducing the entropic penalty of binding.

Critical Stability Warning: The Racemization Trap

Expertise Insight: Researchers often overlook the acidity of the C3-proton in 3-substituted oxindoles.

- Mechanism: The C3-H is acidic (in DMSO, lower in protein pockets). In physiological conditions or basic buffers, it can enolize, leading to rapid racemization.
- Implication: If you use **6-Hydroxy-3-methylindolin-2-one** as a final fragment, you may have an unstable stereocenter.
- Design Solution: The "Best Practice" is to use this fragment as a precursor to generate 3,3-disubstituted oxindoles (quaternary center), which are metabolically stable and stereochemically locked.

Part 2: Experimental Protocols

Protocol A: Synthesis of 3,3-Disubstituted "Warheads" (Quaternary Center Formation)

Objective: To convert the racemizable 3-methyl scaffold into a rigid, non-racemizable 3,3-dialkyl or spiro-oxindole active fragment.

Reagents:

- Substrate: **6-Hydroxy-3-methylindolin-2-one** (1.0 eq)
- Electrophile: Benzyl bromide or substituted alkyl halide (1.1 eq)
- Base: Cesium Carbonate (, 2.5 eq) – Preferred over NaH for functional group tolerance.
- Solvent: Acetonitrile () or DMF.

Step-by-Step Methodology:

- Protection (Crucial): The 6-OH is more acidic (phenolic) than the C3-H. You must protect the 6-OH (e.g., TBS-Cl or Benzyl) or perform a selective O-alkylation first (see Protocol B) before attempting C3-alkylation. Note: If using 2.5 eq base and excess electrophile, you will get simultaneous O- and C-alkylation.
- Reaction Setup: In a flame-dried flask under Argon, dissolve the O-protected intermediate in anhydrous Acetonitrile (0.1 M).
- Deprotonation: Add . Stir at RT for 30 mins. The solution will turn from yellow to deep orange/red (enolate formation).
- Alkylation: Add the electrophile dropwise.
- Temperature: Stir at RT for 4-12 hours. If sluggish, heat to 50°C. Avoid high heat (>80°C) to prevent O-alkylation reversal or polymerization.
- Workup: Dilute with EtOAc, wash with water (x3) to remove DMF/salts. Dry over .
- Validation:

NMR must show the disappearance of the C3-quartet (approx. 3.5 ppm) and the appearance of a singlet methyl group (approx. 1.5 ppm), confirming the quaternary center.

Protocol B: 6-O-Functionalization (The "Solubility Tail")

Objective: To attach a solubilizing group (e.g., morpholine-ethyl chain) to the 6-position.

Reagents:

- Substrate: **6-Hydroxy-3-methylindolin-2-one**
- Linker: 4-(2-Chloroethyl)morpholine hydrochloride (1.2 eq)

- Base: Potassium Carbonate (, 3.0 eq)

- Solvent: Acetone or DMF.

Step-by-Step Methodology:

- Mix: Combine substrate, base, and linker in Acetone (0.2 M).
- Reflux: Heat to reflux (60°C) for 6–12 hours. The phenolic proton is easily removed by carbonate bases.
- Monitoring: Monitor by LC-MS. The starting material (MW ~163) should shift to the product mass.
- Purification: Filter off inorganic salts. Concentrate filtrate. Recrystallize from EtOH or purify via Flash Chromatography (DCM:MeOH 95:5).

Part 3: Visualization & Logic

Design Logic: From Fragment to Lead

The following diagram illustrates the decision tree for transforming the **6-Hydroxy-3-methylindolin-2-one** fragment into a drug-like lead.

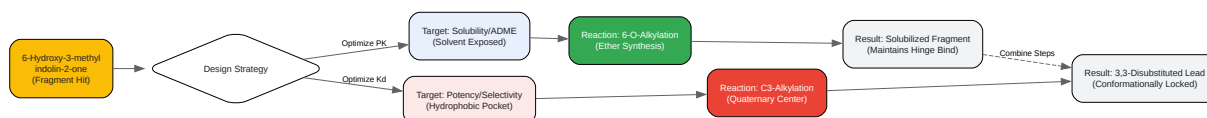

[Click to download full resolution via product page](#)

Caption: Design workflow separating solubility optimization (6-position) from potency/conformation optimization (3-position).

Interaction Map: Hinge Binding Mode

This diagram represents the theoretical binding mode of the scaffold within a typical kinase ATP pocket (e.g., VEGFR2).

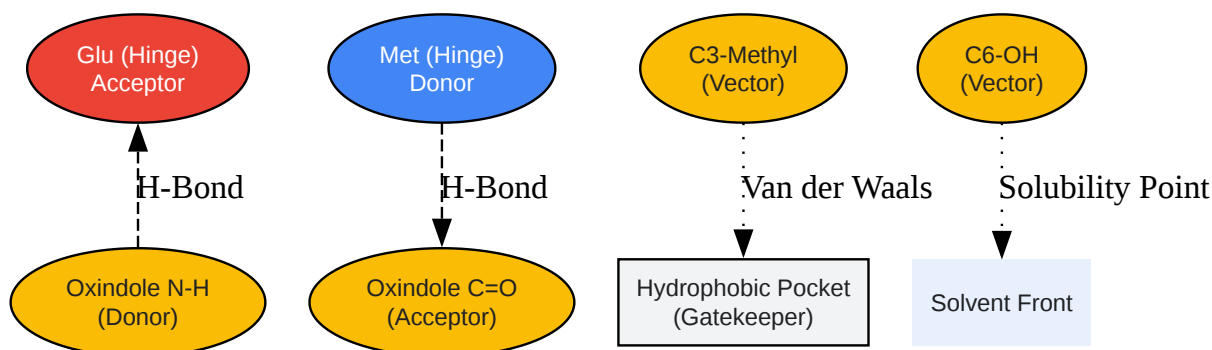

[Click to download full resolution via product page](#)

Caption: Bidentate H-bond network between the Oxindole core and Kinase Hinge residues.

Part 4: Validation Data Summary

When validating this fragment using Surface Plasmon Resonance (SPR) or Isothermal Titration Calorimetry (ITC), expect the following profiles based on substitution patterns.

Fragment Variant	Binding Affinity ()	Ligand Efficiency (LE)	Solubility (PBS, pH 7.4)	Stability (Plasma)
6-OH-3-Me-Oxindole	10 - 100 M	High (>0.4)	High (>500 M)	Low (Racemization risk)
6-OMe-3,3-Dimethyl	1 - 10 M	Moderate (0.35)	Moderate	High (Metabolically Stable)
6-Morpholine-3-Me	50 - 100 M	Low (<0.3)	Very High	Low (Racemization risk)

Interpretation:

- The unsubstituted 6-OH-3-Me is an excellent starting fragment due to high Ligand Efficiency (LE), but it is not a drug candidate itself due to stereochemical instability.
- Recommendation: Prioritize the synthesis of the 3,3-disubstituted variant before advancing to in vivo studies.

Part 5: References

- Vertex Pharmaceuticals. (2018). Optimization of Versatile Oxindoles as Selective PI3K δ Inhibitors. *Journal of Medicinal Chemistry*.^[1] [Link](#)
- Milles, R., et al. (2016). Catalytic asymmetric synthesis of biologically important 3-hydroxyoxindoles.^{[1][2][3]} *Beilstein Journal of Organic Chemistry*. [Link](#)
- Astex Pharmaceuticals. (2020). Fragment-based drug discovery: a practical approach.^{[4][5]} *Nature Reviews Drug Discovery*. [Link](#)
- Li, X., et al. (2012). Approved Small-Molecule ATP-Competitive Kinases Drugs Containing Indole/Azaindole/Oxindole Scaffolds. *Molecules*.^{[1][4][5][6][7][8][9][10][11][12][13][14]} [Link](#)
- ResearchGate. (2022). Mechanisms for racemization of 3-substituted oxindoles in plasma.[Link](#)

Need Custom Synthesis?

BenchChem offers custom synthesis for rare earth carbides and specific isotopic labeling.

Email: info@benchchem.com or [Request Quote Online](#).

Sources

- 1. scilit.com [scilit.com]
- 2. Catalytic asymmetric synthesis of 3-hydroxyoxindole : a potentially bioactive molecule - *RSC Advances* (RSC Publishing) DOI:10.1039/C2RA21131A [pubs.rsc.org]

- 3. BJOC - Catalytic asymmetric synthesis of biologically important 3-hydroxyoxindoles: an update [beilstein-journals.org]
- 4. lifechemicals.com [lifechemicals.com]
- 5. lifechemicals.com [lifechemicals.com]
- 6. This fragment-based drug discovery library is designed to be sociable | Research | Chemistry World [chemistryworld.com]
- 7. Frontiers | In silico Strategies to Support Fragment-to-Lead Optimization in Drug Discovery [frontiersin.org]
- 8. Racemization - Wikipedia [en.wikipedia.org]
- 9. Prestwick Drug-Fragment Library - Prestwick Chemical Libraries [prestwickchemical.com]
- 10. Development and applications of fragment based drug design methods | BioMolecular Engineering Research Center [bu.edu]
- 11. Stereo/regio-selective access to substituted 3-hydroxy-oxindoles with anti-proliferative assessment and in silico validation - PMC [pmc.ncbi.nlm.nih.gov]
- 12. mdpi.com [mdpi.com]
- 13. Diversified strategy for the synthesis of DNA-encoded oxindole libraries - PMC [pmc.ncbi.nlm.nih.gov]
- 14. 6-Hydroxy-3-(hydroxyimino)indolin-2-one - PMC [pmc.ncbi.nlm.nih.gov]
- To cite this document: BenchChem. [Application Note: 6-Hydroxy-3-methylindolin-2-one in Kinase Inhibitor Design]. BenchChem, [2026]. [Online PDF]. Available at: [<https://www.benchchem.com/product/b11918152/docs#application-note-6-hydroxy-3-methylindolin-2-one-in-kinase-inhibitor-design>]

Disclaimer & Data Validity:

The information provided in this document is for Research Use Only (RUO) and is strictly not intended for diagnostic or therapeutic procedures. While BenchChem strives to provide accurate protocols, we make no warranties, express or implied, regarding the fitness of this product for every specific experimental setup.

Technical Support: The protocols provided are for reference purposes. Unsure if this reagent suits your experiment?

Need Industrial/Bulk Grade? [Request Custom Synthesis Quote](#)

BenchChem

Our mission is to be the trusted global source of essential and advanced chemicals, empowering scientists and researchers to drive progress in science and industry.

Contact

Address: 3281 E Guasti Rd
Ontario, CA 91761, United States
Phone: (601) 213-4426
Email: info@benchchem.com

[Contact our Ph.D. Support Team for a compatibility check](#)