

Technical Support Center: DS-3032b Animal Model Studies

Author: BenchChem Technical Support Team. **Date:** April 2026

Compound of Interest

Compound Name: DS-3032b

Cat. No.: B1191737

[Get Quote](#)

This technical support center provides guidance for researchers, scientists, and drug development professionals on minimizing and managing toxicities associated with the MDM2 inhibitor **DS-3032b** (milademetan) in preclinical animal models.

Frequently Asked Questions (FAQs) & Troubleshooting

Q1: What is the mechanism of action of **DS-3032b** and how does it relate to its on-target toxicity?

A1: **DS-3032b** is a potent and selective small-molecule inhibitor of the Mouse Double Minute 2 (MDM2)-p53 interaction.[1][2] By binding to MDM2, it prevents the degradation of the tumor suppressor protein p53.[3] This leads to the reactivation of p53 signaling pathways, resulting in cell cycle arrest, senescence, and apoptosis in tumor cells with wild-type TP53.[4] The on-target toxicities, such as hematological and gastrointestinal side effects, are also a consequence of p53 activation in normal tissues.

Q2: What are the most common toxicities observed with **DS-3032b** in animal models?

A2: While some preclinical studies in xenograft mouse models reported no obvious signs of toxicity at therapeutic doses, clinical data and a deeper understanding of the mechanism suggest that researchers should be vigilant for potential on-target toxicities.[4] The most anticipated toxicities, based on clinical trials, are hematological (thrombocytopenia and neutropenia) and gastrointestinal (nausea, vomiting, diarrhea, and decreased appetite).[1][2][5] Therefore, careful monitoring of animal well-being, including body weight and complete blood counts, is crucial.

Q3: How can I minimize the toxicity of **DS-3032b** in my animal experiments?

A3: A key strategy to mitigate the toxicity of **DS-3032b** is the implementation of an intermittent dosing schedule.[1][6] This approach allows for recovery of normal tissues, particularly the bone marrow, between treatment cycles.[1] For example, a regimen of daily dosing for a few consecutive days followed by a treatment-free period has been shown to be effective while reducing the severity of adverse events in clinical settings.[1][6] Careful dose selection based on preliminary dose-range-finding studies is also essential.

Q4: What parameters should I monitor to assess **DS-3032b** toxicity in my animal models?

A4: Regular and thorough monitoring is critical. Key parameters include:

- **Body Weight:** Monitor and record body weight at least twice weekly.[7][8] A significant weight loss (e.g., >15%) may necessitate a dose reduction or interruption of treatment.[9]
- **Clinical Signs:** Daily observation for any signs of distress, such as changes in posture, activity levels, grooming, and food/water intake.
- **Complete Blood Counts (CBCs):** If feasible, periodic blood collection for CBC analysis is highly recommended to monitor for thrombocytopenia and neutropenia.
- **Tumor Volume:** While primarily an efficacy endpoint, monitoring tumor growth is also important for overall animal health assessment.[8][10]

Q5: What should I do if I observe significant toxicity in my experimental animals?

A5: If significant toxicity is observed (e.g., substantial body weight loss, severe clinical signs of distress, or marked cytopenias), the following actions should be considered in consultation with

your institution's animal care and use committee:

- Dose Reduction: Lower the dose of **DS-3032b** for subsequent treatments.
- Treatment Interruption: Temporarily halt dosing to allow the animal to recover.
- Modification of Dosing Schedule: Switch to an intermittent dosing regimen if a continuous schedule is being used.
- Supportive Care: Provide supportive care as recommended by a veterinarian, which may include hydration and nutritional support.

Quantitative Data Summary

Table 1: Overview of **DS-3032b** Dosing and Observed Toxicities in Preclinical and Clinical Studies

Study Type	Model Organism	Dosing Regimen	Observed Toxicities	Reference(s)
Preclinical (Xenograft)	Mice	25-50 mg/kg/day, oral administration	Dose-dependent tumor growth inhibition. Some studies report no obvious signs of toxicity at these doses.	[11]
Preclinical (Xenograft)	Mice	100 mg/kg/day, oral administration	Antitumor activity observed.	[12]
Phase I Clinical Trial	Human	Continuous or interrupted schedules (15-240 mg QD)	Dose-limiting toxicities: thrombocytopenia, neutropenia. Common adverse events: nausea, fatigue, anemia.	[1]
Phase II Clinical Trial	Human	260 mg QD, intermittent schedule (e.g., 3 of 14 days)	Manageable safety profile with Grade 3 or 4 events including thrombocytopenia, neutropenia, anemia, and diarrhea.	[2][5]

Experimental Protocols

Protocol 1: In Vivo Xenograft Study with DS-3032b

- Animal Model: Immunocompromised mice (e.g., NOD/SCID or NSG) are typically used for xenograft studies.

- Tumor Cell Implantation: Subcutaneously implant tumor cells known to have wild-type TP53.
- Tumor Growth Monitoring: Allow tumors to reach a predetermined size (e.g., 100-200 mm³) before randomizing animals into treatment and control groups.[9]
- Dosing:
 - Vehicle Control Group: Administer the vehicle used to formulate **DS-3032b**.
 - **DS-3032b** Treatment Group(s): Administer **DS-3032b** orally at the desired dose and schedule (e.g., daily or intermittent).
- Toxicity Monitoring:
 - Measure and record body weight and tumor volume 2-3 times per week.[8][13]
 - Perform daily clinical observations for signs of toxicity.
 - If possible, collect blood samples at baseline and at specified intervals for complete blood count analysis.
- Efficacy Assessment: Continue treatment and monitoring for the planned duration of the study. The primary efficacy endpoint is often tumor growth inhibition.
- Endpoint: Euthanize animals when tumors reach the maximum allowed size as per institutional guidelines, or if significant toxicity is observed.

Protocol 2: Monitoring and Management of DS-3032b Toxicity

- Body Weight Monitoring:
 - Establish a baseline body weight before the start of treatment.
 - Weigh each animal at least twice a week.
 - If an animal experiences a body weight loss of >15% from baseline, consider a dose reduction or treatment holiday.[9]

- Clinical Observation:
 - Conduct daily visual checks of all animals.
 - Look for signs of lethargy, ruffled fur, hunched posture, and reduced food/water consumption.
 - Document all observations.
- Hematological Monitoring (if applicable):
 - Collect a baseline blood sample prior to treatment initiation.
 - Collect subsequent blood samples at nadir time points if known, or at regular intervals during the treatment cycle.
 - Analyze samples for platelet and neutrophil counts.
 - Significant decreases from baseline may warrant modification of the treatment plan.

Visualizations

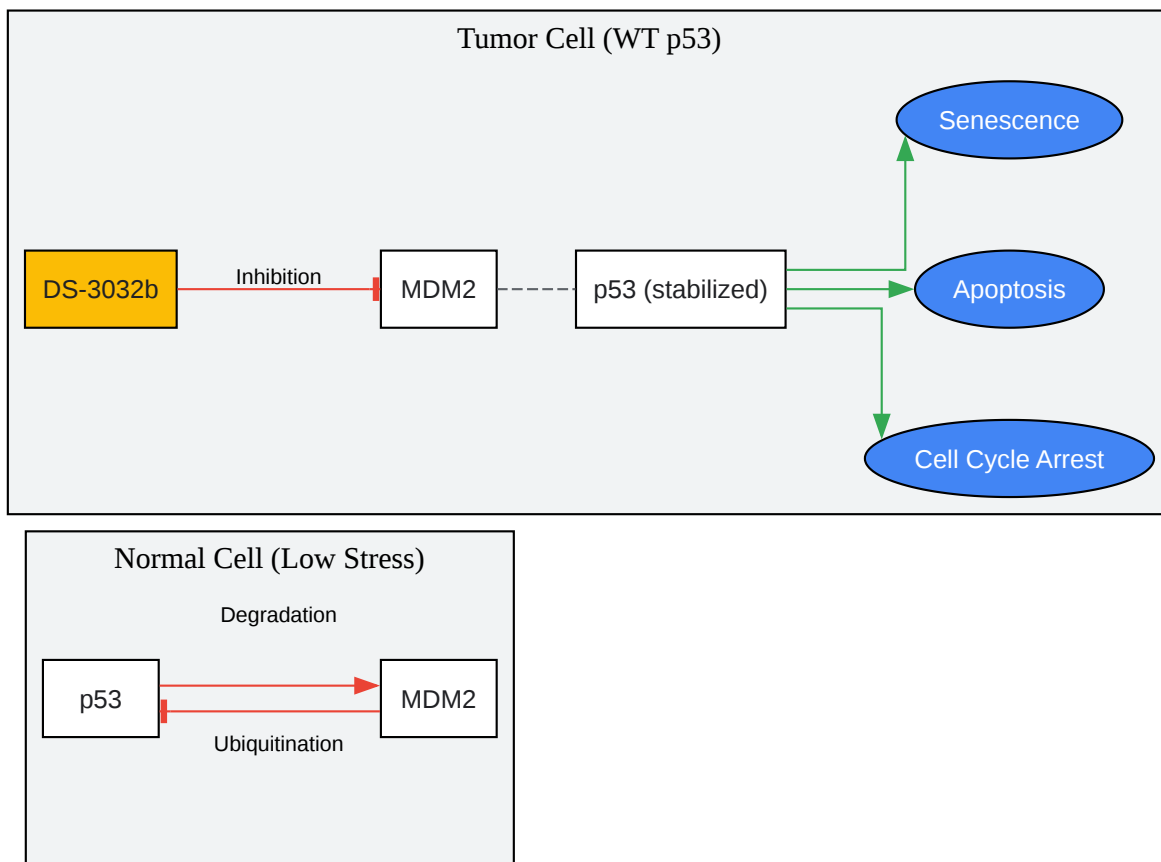

[Click to download full resolution via product page](#)

Caption: Mechanism of action of **DS-3032b** in reactivating p53 signaling.

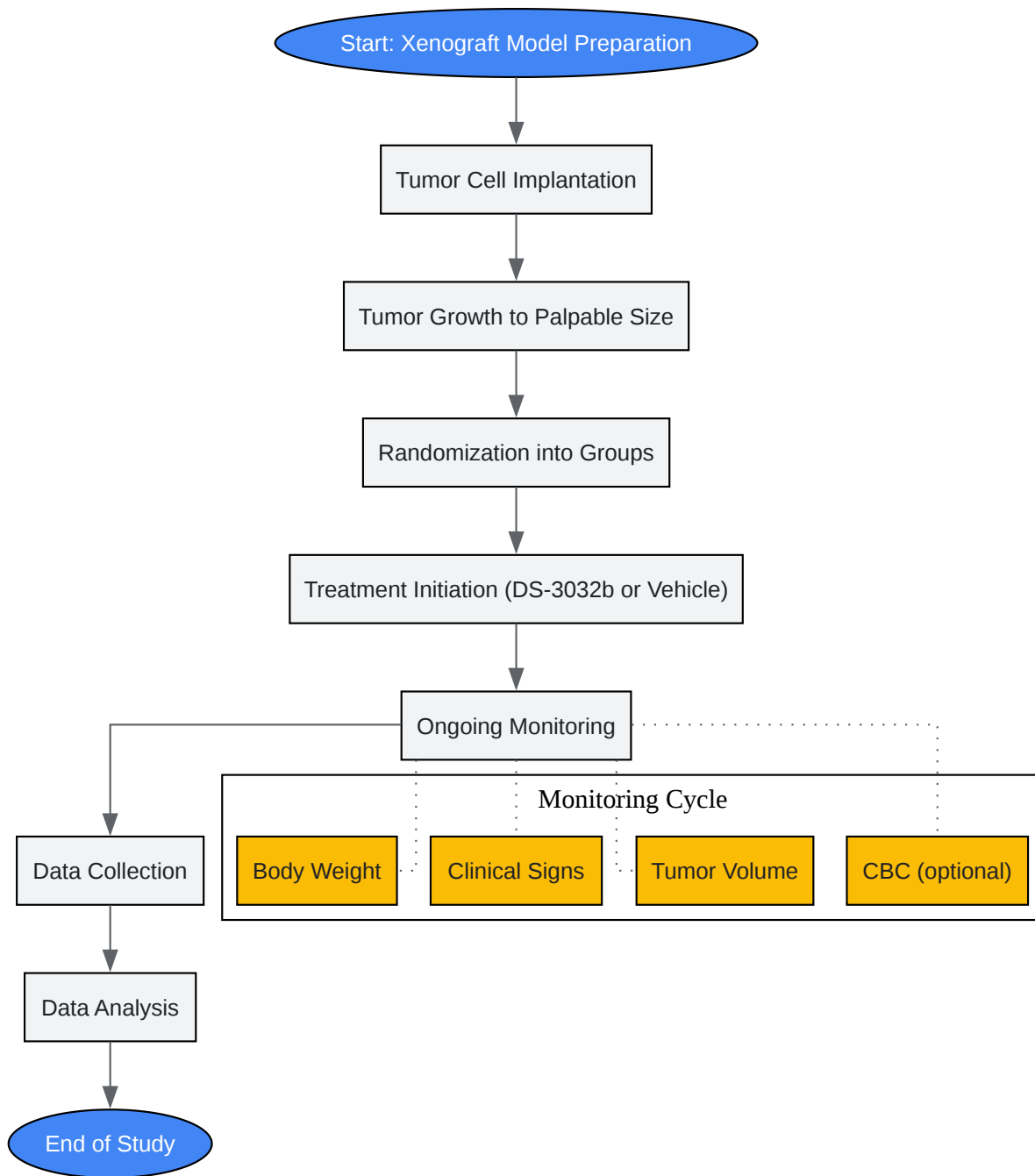

[Click to download full resolution via product page](#)

Caption: General experimental workflow for in vivo studies with **DS-3032b**.

Need Custom Synthesis?

BenchChem offers custom synthesis for rare earth carbides and specific isotopic labeling.

Email: info@benchchem.com or [Request Quote Online](#).

References

- [1. ascopubs.org \[ascopubs.org\]](https://ascopubs.org)
- [2. Milademetan in Advanced Solid Tumors with MDM2 Amplification and Wild-type TP53: Preclinical and Phase II Clinical Trial Results - PubMed \[pubmed.ncbi.nlm.nih.gov\]](#)
- [3. Molecular docking of DS-3032B, a mouse double minute 2 enzyme antagonist with potential for oncology treatment development - PMC \[pmc.ncbi.nlm.nih.gov\]](#)
- [4. Reactivating TP53 signaling by the novel MDM2 inhibitor DS-3032b as a therapeutic option for high-risk neuroblastoma - PMC \[pmc.ncbi.nlm.nih.gov\]](#)
- [5. aacrjournals.org \[aacrjournals.org\]](https://aacrjournals.org)
- [6. aacrjournals.org \[aacrjournals.org\]](https://aacrjournals.org)
- [7. researchgate.net \[researchgate.net\]](https://researchgate.net)
- [8. researchgate.net \[researchgate.net\]](https://researchgate.net)
- [9. Assessment of Patient-Derived Xenograft Growth and Antitumor Activity: The NCI PDXNet Consensus Recommendations - PMC \[pmc.ncbi.nlm.nih.gov\]](#)
- [10. Diagnostic Ability of Methods Depicting Distress of Tumor-Bearing Mice - PMC \[pmc.ncbi.nlm.nih.gov\]](#)
- [11. Predictive gene signatures determine tumor sensitivity to MDM2 inhibition - PMC \[pmc.ncbi.nlm.nih.gov\]](#)
- [12. researchgate.net \[researchgate.net\]](https://researchgate.net)
- [13. dctd.cancer.gov \[dctd.cancer.gov\]](https://dctd.cancer.gov)
- To cite this document: BenchChem. [Technical Support Center: DS-3032b Animal Model Studies]. BenchChem, [2026]. [Online PDF]. Available at: [\[https://www.benchchem.com/product/b1191737/docs#technical-support-center-ds-3032b-animal-model-studies\]](https://www.benchchem.com/product/b1191737/docs#technical-support-center-ds-3032b-animal-model-studies)

Disclaimer & Data Validity:

The information provided in this document is for Research Use Only (RUO) and is strictly not intended for diagnostic or therapeutic procedures. While BenchChem strives to provide accurate protocols, we make no warranties, express or implied, regarding the fitness of this product for every specific experimental setup.

Technical Support: The protocols provided are for reference purposes. Unsure if this reagent suits your experiment?

Need Industrial/Bulk Grade? [Request Custom Synthesis Quote](#)

BenchChem

Our mission is to be the trusted global source of essential and advanced chemicals, empowering scientists and researchers to drive progress in science and industry.

Contact

Address: 3281 E Guasti Rd
Ontario, CA 91761, United States
Phone: (601) 213-4426
Email: info@benchchem.com

[Contact our Ph.D. Support Team for a compatibility check](#)