

# Technical Guide: Vilazodone-D8 Chemical Structure and Synthesis Pathway[1]

**Author:** BenchChem Technical Support Team. **Date:** May 2026

## Compound of Interest

Compound Name: Vilazodone D8

Cat. No.: B1191649

[Get Quote](#)

## Executive Summary

Vilazodone-D8 (CAS: 1794789-93-7) is the deuterated isotopologue of Vilazodone, a serotonin partial agonist reuptake inhibitor (SPARI) used in the treatment of Major Depressive Disorder (MDD).[1][2][3] It serves as a critical Internal Standard (IS) in bioanalytical workflows (LC-MS/MS) for therapeutic drug monitoring and pharmacokinetic profiling.[1]

This guide details the structural specifications and the convergent synthesis pathway of Vilazodone-D8.[1] Unlike the non-deuterated parent, the synthesis of the D8 variant relies on the strategic incorporation of a piperazine-d8 moiety, ensuring isotopic stability and preventing metabolic deuterium-hydrogen exchange (D/H exchange) during analysis.

## Chemical Structure & Isotopic Configuration

### Structural Identity

Vilazodone-D8 is characterized by the replacement of eight protium (

H) atoms with deuterium (

H) on the piperazine ring.[1] This specific labeling site is chosen because the piperazine ring is

centrally located and structurally rigid, minimizing the risk of metabolic scrambling compared to the butyl linker.

Parameter	Data
Chemical Name	5-(4-[4-(5-cyano-1H-indol-3-yl)butyl]piperazin-1-yl-2,2,3,3,5,5,6,6-d8)-1-benzofuran-2-carboxamide
CAS Number	1794789-93-7
Molecular Formula	
Molecular Weight	449.58 g/mol (approx. +8 Da shift from parent)
Parent Compound	Vilazodone ( , MW 441.[1][3][4][5]53)
Isotopic Purity	Typically 99% Deuterium enrichment

## SMILES Representation

## Retrosynthetic Analysis

The synthesis of Vilazodone-D8 follows a convergent strategy.[1] The molecule is disconnected at the tertiary amine of the piperazine ring. This reveals two primary precursors:

- Fragment A (Electrophile): 3-(4-chlorobutyl)-1H-indole-5-carbonitrile.[1][5][6]
- Fragment B (Nucleophile - Deuterated): 5-(piperazin-1-yl-d8)benzofuran-2-carboxamide.[1]

The deuterium source is Piperazine-d8, a commercially available stable isotope reagent.[1]

## Pathway Logic Diagram (Graphviz)[1]

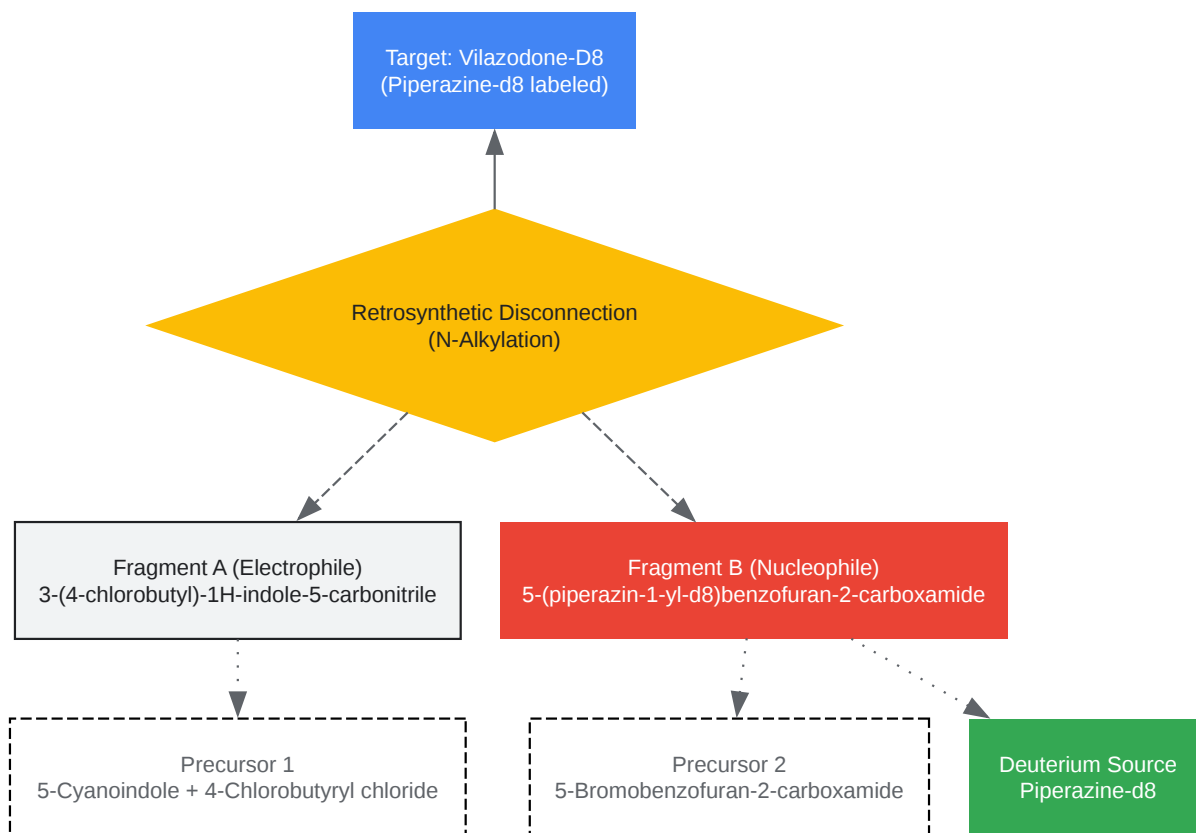

[Click to download full resolution via product page](#)

Caption: Retrosynthetic breakdown identifying Piperazine-d8 as the core isotopic source.

## Detailed Synthesis Protocols

### Phase 1: Synthesis of the Indole Linker (Fragment A)

Objective: Create the alkylating arm containing the indole core. This step does not involve deuterium.[1][4]

Reagents: 5-Cyanoindole, 4-Chlorobutyryl chloride,

,

, TFA.[1]

- Friedel-Crafts Acylation:
  - Dissolve 5-cyanoindole in dichloromethane (DCM).
  - Add  
  
(Lewis acid catalyst) at 0°C, followed by dropwise addition of 4-chlorobutyryl chloride.[1]
  - Mechanism:[7][8][9] Electrophilic aromatic substitution at the C3 position of the indole.
  - Product: 3-(4-chlorobutyryl)-1H-indole-5-carbonitrile.[1][5][6][9]
- Carbonyl Reduction:
  - Treat the acylated intermediate with Sodium Borohydride (  
  
) in Trifluoroacetic acid (TFA) or Isopropanol.
  - Causality: Complete reduction of the ketone to a methylene group is required to form the saturated butyl chain.
  - Final Intermediate A:3-(4-chlorobutyl)-1H-indole-5-carbonitrile.[1][5][6]

## Phase 2: Synthesis of the Deuterated Benzofuran Core (Fragment B)

Objective: Incorporate the isotope label.[10] This is the critical deviation from the standard synthesis.

Reagents: 5-Bromobenzofuran-2-carboxamide, Piperazine-d8,

, BINAP,

[1]

- Substrate Preparation:
  - Start with 5-bromobenzofuran-2-carboxamide.[1][5][6]
- Buchwald-Hartwig Amination (Deuterated):

- Reaction: Cross-coupling of the aryl bromide with Piperazine-d8.[1]
- Catalyst System: Tris(dibenzylideneacetone)dipalladium(0) ( ) and BINAP (ligand).
- Base: Cesium Carbonate ( ) in Toluene or Dioxane at 100°C.
- Note: While standard synthesis might use nucleophilic aromatic substitution ( ), the Palladium-catalyzed route is preferred here to maximize the yield of the expensive deuterated reagent and prevent side reactions.
- Stoichiometry: Use a slight excess of Piperazine-d8 (1.2 eq) to prevent bis-arylation.[1]
- Purification:
  - Isolate the product via silica gel chromatography.
  - Final Intermediate B:5-(piperazin-1-yl-d8)benzofuran-2-carboxamide.[1]

### Phase 3: Convergent Coupling (Final Assembly)

Objective: Link Fragment A and Fragment B to form Vilazodone-D8.

Reagents:

, Acetonitrile ( ), NaI (catalytic).

- N-Alkylation:
  - Dissolve Intermediate B (Deuterated Benzofuran, 1.0 eq) in Acetonitrile.
  - Add Intermediate A (Indole Linker, 1.1 eq).
  - Add Potassium Carbonate (

, 3.0 eq) as the base to scavenge HCl.

- Catalyst: Add catalytic Sodium Iodide (NaI, 0.1 eq).
- Causality: NaI converts the alkyl chloride (Fragment A) into a more reactive alkyl iodide in situ (Finkelstein reaction), significantly accelerating the substitution rate.
- Reflux:
  - Heat to reflux (approx. 80-82°C) for 12-24 hours. Monitor via LC-MS for the disappearance of the benzofuran amine.[1]
- Workup & Salt Formation:
  - Cool, filter inorganic salts, and concentrate the solvent.
  - Purify via column chromatography.[1]
  - Optional: Treat with HCl in ethanol to generate Vilazodone-D8 Hydrochloride if a salt form is required for solubility.[1]

## Analytical Validation Standards

To ensure the integrity of the synthesized Vilazodone-D8, the following validation metrics must be met.

Method	Expected Observation	Purpose
1H-NMR	Absence of signals at 3.0-3.5 ppm region (typically associated with piperazine protons).[1]	Confirms >98% Deuterium incorporation at the piperazine ring.
HRMS (ESI+)	peak at 450.28 (approx).[1]	Confirms molecular weight shift (+8 Da vs 442.20 for parent).
Isotopic Distribution	Minimal presence of D0, D1-D7 isotopologues.[1]	Ensures "spectral cleanliness" for use as an Internal Standard.

## Synthesis Workflow Visualization

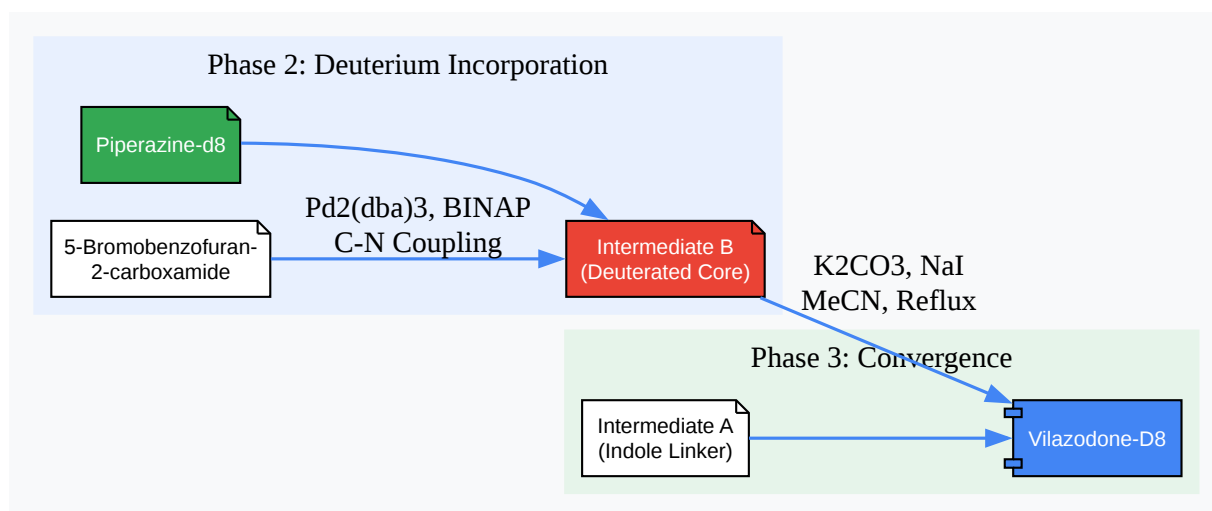

[Click to download full resolution via product page](#)

Caption: Step-by-step reaction flow from deuterated starting materials to final product.

## References

- MedChemExpress.Vilazodone-d8 Product Datasheet & Structure.[1] Retrieved from [1]
- Hu, H., & Su, W. (2018). An investigation of the synthesis of vilazodone.[5][8][11] ResearchGate.[1][5] Retrieved from
- Cayman Chemical.Vilazodone-d8 Analytical Standard Reference.[1][12] Retrieved from [1]
- TargetMol.Vilazodone D8 Chemical Properties and SMILES. Retrieved from [1]
- National Center for Biotechnology Information (NCBI).Vilazodone PubChem Compound Summary.[1] Retrieved from [1]

### Need Custom Synthesis?

BenchChem offers custom synthesis for rare earth carbides and specific isotopic labeling.

Email: [info@benchchem.com](mailto:info@benchchem.com) or [Request Quote Online](#).

## Sources

1. Vilazodone | C26H27N5O2 | CID 6918314 - PubChem [[pubchem.ncbi.nlm.nih.gov](https://pubchem.ncbi.nlm.nih.gov)]
2. medchemexpress.com [[medchemexpress.com](https://medchemexpress.com)]
3. Vilazodone-d8 | TargetMol [[targetmol.com](https://targetmol.com)]
4. Vilazodone - Wikipedia [[en.wikipedia.org](https://en.wikipedia.org)]
5. researchgate.net [[researchgate.net](https://researchgate.net)]
6. researchgate.net [[researchgate.net](https://researchgate.net)]
7. data.epo.org [[data.epo.org](https://data.epo.org)]
8. CN103159749A - Synthesis method for antidepressant drug vilazodone - Google Patents [[patents.google.com](https://patents.google.com)]
9. CN105601536A - Vilazodone intermediate preparation method - Google Patents [[patents.google.com](https://patents.google.com)]
10. resolvemass.ca [[resolvemass.ca](https://resolvemass.ca)]
11. Structural basis of vilazodone dual binding mode to the serotonin transporter - PMC [[pmc.ncbi.nlm.nih.gov](https://pmc.ncbi.nlm.nih.gov)]

- [12. caymanchem.com \[caymanchem.com\]](https://www.caymanchem.com)
- To cite this document: BenchChem. [Technical Guide: Vilazodone-D8 Chemical Structure and Synthesis Pathway[1]]. BenchChem, [2026]. [Online PDF]. Available at: [<https://www.benchchem.com/product/b1191649/docs#technical-guide-vilazodone-d8-chemical-structure-and-synthesis-pathway-1>]

---

### Disclaimer & Data Validity:

The information provided in this document is for Research Use Only (RUO) and is strictly not intended for diagnostic or therapeutic procedures. While BenchChem strives to provide accurate protocols, we make no warranties, express or implied, regarding the fitness of this product for every specific experimental setup.

**Technical Support:** The protocols provided are for reference purposes. Unsure if this reagent suits your experiment?

**Need Industrial/Bulk Grade?** [Request Custom Synthesis Quote](#)

## BenchChem

Our mission is to be the trusted global source of essential and advanced chemicals, empowering scientists and researchers to drive progress in science and industry.

### Contact

Address: 3281 E Guasti Rd  
Ontario, CA 91761, United States  
Phone: (601) 213-4426  
Email: [info@benchchem.com](mailto:info@benchchem.com)

[Contact our Ph.D. Support Team for a compatibility check](#)