

# Technical Comparison: QAQ Dichloride vs. Next-Gen Azobenzene Channel Blockers

**Author:** BenchChem Technical Support Team. **Date:** May 2026

## Compound of Interest

Compound Name: QAQ dichloride

Cat. No.: B1191935

[Get Quote](#)

## Executive Summary: The Specificity Paradox

In the toolkit of photopharmacology, QAQ (Quaternary Ammonium-Azobenzene-Quaternary Ammonium) represents a paradigm shift from "global" to "targeted" optical control.

While first-generation photoswitches like AAQ are membrane-permeable and indiscriminately photosensitize all neurons in a tissue, QAQ is membrane-impermeable. It functions as a "Trojan Horse," entering cells only through large-pore nociceptive channels (e.g., TRPV1, P2X) when they are activated. Once inside, it becomes trapped and photosensitizes voltage-gated ion channels (Nav, Kv) specifically within that cell population.

Key Decision Matrix:

- Choose QAQ if: You need to optically silence specific cell types (e.g., nociceptors) based on their expression of entry channels (TRPV1/P2X) without genetic manipulation.
- Choose AAQ/DENAQ if: You require broad, non-selective photosensitization of a whole neuronal population or retinal ganglion cells (vision restoration).

## Mechanistic Architecture

## The "Trojan Horse" Mechanism (QAQ)

QAQ is a bis-quaternary ammonium compound. The permanent positive charges prevent passive diffusion across the lipid bilayer.

- Entry: QAQ enters the cytosol only when large-pore channels (TRPV1, TRPA1, P2X7) are dilated by agonists (Capsaicin, ATP).
- Trapping: Upon agonist washout, the entry pore closes, trapping QAQ intracellularly.
- Blockade: In the dark or under green light (500 nm), QAQ adopts the trans configuration, binding to the intracellular vestibule of voltage-gated K<sup>+</sup> (Kv) and Na<sup>+</sup> (Nav) channels, blocking ion flow.<sup>[1][2]</sup>
- Release: UV light (360–380 nm) isomerizes QAQ to cis, shortening the molecule and relieving the block.

## Passive Diffusion Mechanism (AAQ, DENAQ)

AAQ (Acrylamide-Azobenzene-Quaternary ammonium) contains a lipophilic tail, allowing it to permeate membranes passively. It accumulates in all cells, inserting its hydrophobic tail into the membrane while the QA head blocks the channel pore.

## Mechanistic Pathway Diagram

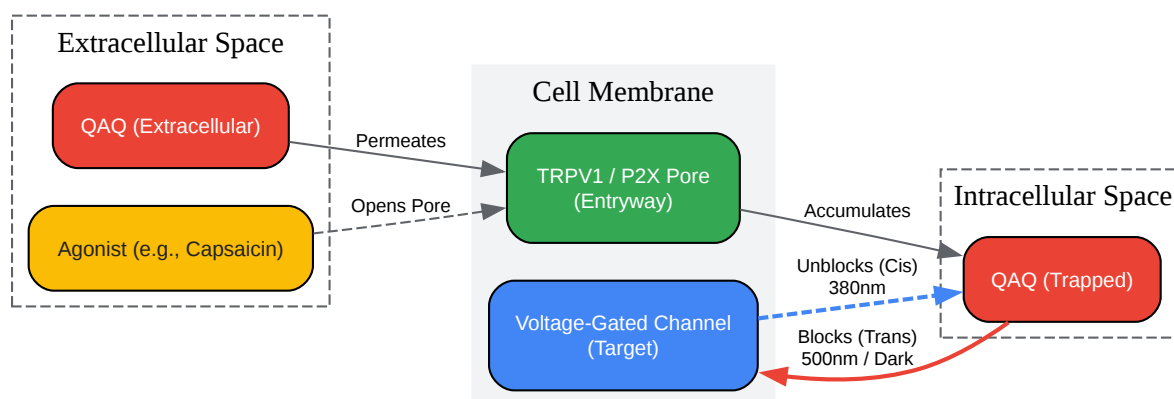

[Click to download full resolution via product page](#)

Figure 1: The selective "Trojan Horse" loading mechanism of QAQ. Unlike AAQ, QAQ requires an open entry channel to access its intracellular target.

## Comparative Performance Analysis

The following table contrasts QAQ with its primary alternatives: AAQ (first-gen), DENAQ (red-shifted), and QENAQ (red-shifted QAQ derivative).

Feature	QAQ Dichloride	AAQ	DENAQ	BENAQ
Permeability	Impermeable (Requires entry channel)	Permeable (Lipophilic tail)	Permeable	Permeable
Selectivity	High (Targeted to TRPV1/P2X+ cells)	Low (Global labeling)	Low (Global labeling)	Low
Blocking State	Trans-Blocker (Blocks in Dark/Green)	Trans-Blocker (Blocks in Dark/Green)	Trans-Blocker (Blocks in Dark)	Trans-Blocker
Unblocking Light	UV (360–380 nm)	UV (360–380 nm)	Blue/Cyan (450–500 nm)	Blue/Cyan (470 nm)
Restoring Light	Green (500 nm)	Green (500 nm)	Dark Relaxation (Fast)	Dark Relaxation
Thermal Relaxation	Slow (Minutes)	Slow (Minutes)	Fast (Seconds to Minutes)	Fast
Primary Application	Pain research (Nociceptor silencing)	General neuronal silencing	Vision restoration (RGCs)	Vision restoration
Solubility	High (Water/Saline)	Low (Requires DMSO)	Moderate (DMSO)	Moderate

## Key Technical Insights:

- **Spectral Sensitivity:** QAQ and AAQ require UV light for unblocking, which can be phototoxic in long-term experiments. DENAQ and BENAQ are "red-shifted" to the visible spectrum (blue/green), reducing toxicity and improving tissue penetration.
- **Kinetics:** DENAQ has a faster thermal relaxation rate, meaning it turns itself "off" (back to blocking state) rapidly in the dark, whereas QAQ is bistable and requires a second wavelength (green) to re-block quickly.

## Experimental Protocol: Activity-Dependent Loading of QAQ

This protocol describes the selective silencing of TRPV1-expressing sensory neurons using QAQ.

Reagents:

- **QAQ Dichloride** (stored at -20°C, protected from light).
- Capsaicin (TRPV1 agonist).[\[3\]](#)[\[4\]](#)[\[5\]](#)[\[6\]](#)
- Standard Extracellular Solution (SES).

## Workflow Diagram

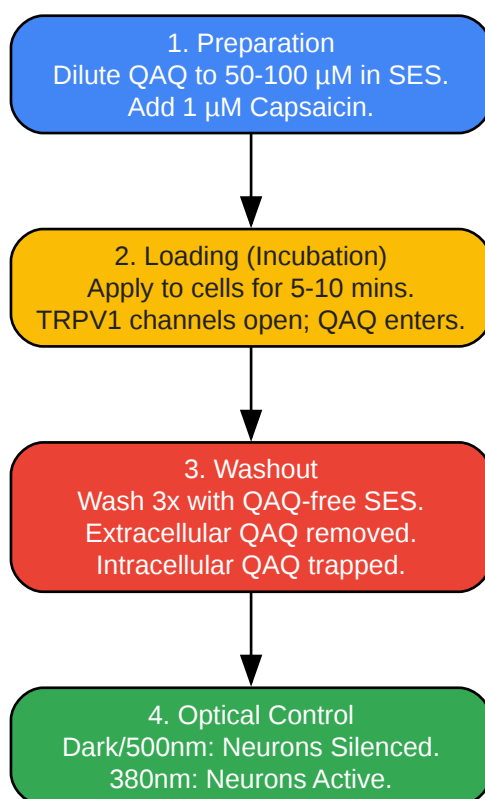

[Click to download full resolution via product page](#)

Figure 2: Step-by-step workflow for targeted optical silencing using QAQ.

## Detailed Methodology

- Preparation: Prepare a loading solution containing 50–100 μM QAQ and 1 μM Capsaicin in physiological saline. Note: Keep QAQ solutions in the dark or under red light to maintain the trans-isomer.
- Loading: Perfusion or bath-apply the loading solution to the tissue/culture for 5–15 minutes.
  - Mechanism Check: Capsaicin opens TRPV1 channels.[3][4][6] The cationic QAQ permeates the dilated pore.
- Washout: Perfuse with standard saline (free of QAQ and Capsaicin) for 5–10 minutes.
  - Critical Step: This removes QAQ from the extracellular space and from cells lacking TRPV1. TRPV1 channels close upon capsaicin removal, trapping QAQ inside the target neurons.

- Verification (Electrophysiology):
  - Voltage Clamp: Hold neurons at -70 mV. Apply depolarizing steps to elicit Na<sup>+</sup>/K<sup>+</sup> currents.
  - Illumination:
    - 500 nm (Green): Maximize blockade. Currents should be significantly inhibited (up to 80-90% block depending on loading).
    - 380 nm (UV): Relieve blockade. Currents should recover rapidly.
- Control: Non-TRPV1 neurons in the same culture should show no photosensitivity, confirming selective loading.

## Limitations & Troubleshooting

- Incomplete Washout: If non-target cells show photosensitivity, extend the washout period. Extracellular QAQ can act as a weak external blocker.
- UV Toxicity: Prolonged exposure to 360–380 nm light can damage cells. Use pulsed light or switch to red-shifted derivatives (like QENAQ) if available, though QENAQ is less commercially common than QAQ.
- Voltage Dependence: QAQ block is slightly voltage-dependent (open-channel blocker).[2] Blockade is most effective at depolarized potentials.

## References

- Mourot, A., et al. (2011). Rapid optical control of nociception with an ion-channel photoswitch. Nature Methods. [\[Link\]](#)
  - Foundational paper describing QAQ and the "Trojan Horse" entry mechanism.
- Mourot, A., et al. (2012). Tuning Photochromic Ion Channel Blockers. ACS Chemical Neuroscience. [\[Link\]](#)
  - Comparison of QAQ, AAQ, and deriv

- Tochitsky, I., et al. (2014). Restoring visual function to blind mice with a photoswitch that capsulates the receptor. *Neuron*. [2][4][7] [[Link](#)]
  - Describes DENAQ and the shift to visible light switching.
- Kramer, R. H., et al. (2013). Photochemical tools for remote control of ion channels in excitable cells. *Current Opinion in Neurobiology*. [[Link](#)]
  - Review of the biophysics of azobenzene blockers.

### Need Custom Synthesis?

BenchChem offers custom synthesis for rare earth carbides and specific isotopic labeling.

Email: [info@benchchem.com](mailto:info@benchchem.com) or [Request Quote Online](#).

## Sources

- 1. [researchgate.net](https://www.researchgate.net) [[researchgate.net](https://www.researchgate.net)]
- 2. Understanding and improving photo-control of ion channels in nociceptors with azobenzene photo-switches - PMC [[pmc.ncbi.nlm.nih.gov](https://pubmed.ncbi.nlm.nih.gov/23811111/)]
- 3. Activity-dependent targeting of TRPV1 with a pore-permeating capsaicin analog - PubMed [[pubmed.ncbi.nlm.nih.gov](https://pubmed.ncbi.nlm.nih.gov/23811111/)]
- 4. [researchgate.net](https://www.researchgate.net) [[researchgate.net](https://www.researchgate.net)]
- 5. [mdpi.com](https://www.mdpi.com) [[mdpi.com](https://www.mdpi.com)]
- 6. Activity-dependent targeting of TRPV1 with a pore-permeating capsaicin analog - PMC [[pmc.ncbi.nlm.nih.gov](https://pubmed.ncbi.nlm.nih.gov/23811111/)]
- 7. Photochemical control of endogenous ion channels and cellular excitability - PMC [[pmc.ncbi.nlm.nih.gov](https://pubmed.ncbi.nlm.nih.gov/23811111/)]
- To cite this document: BenchChem. [Technical Comparison: QAQ Dichloride vs. Next-Gen Azobenzene Channel Blockers]. BenchChem, [2026]. [Online PDF]. Available at: [<https://www.benchchem.com/product/b1191935/docs#technical-comparison-qaq-dichloride-vs-next-gen-azobenzene-channel-blockers>]

---

### Disclaimer & Data Validity:

The information provided in this document is for Research Use Only (RUO) and is strictly not intended for diagnostic or therapeutic procedures. While BenchChem strives to provide accurate protocols, we make no warranties, express or implied, regarding the fitness of this product for every specific experimental setup.

**Technical Support:** The protocols provided are for reference purposes. Unsure if this reagent suits your experiment?

**Need Industrial/Bulk Grade?** [Request Custom Synthesis Quote](#)

## BenchChem

Our mission is to be the trusted global source of essential and advanced chemicals, empowering scientists and researchers to drive progress in science and industry.

### Contact

Address: 3281 E Guasti Rd  
Ontario, CA 91761, United States  
Phone: (601) 213-4426  
Email: [info@benchchem.com](mailto:info@benchchem.com)

[Contact our Ph.D. Support Team for a compatibility check](#)