

Introduction: Targeting a Core Cancer Pathway

Author: BenchChem Technical Support Team. **Date:** May 2026

Compound of Interest

Compound Name: MSC2363318A (M2698)

Cat. No.: B1191806

[Get Quote](#)

The Phosphoinositide 3-kinase (PI3K)/Akt/mTOR signaling pathway is a critical intracellular cascade that governs fundamental cellular processes, including cell growth, proliferation, survival, and metabolism.[1] Its dysregulation is a hallmark of various human cancers, making it a prime target for therapeutic intervention.[1][2][3] Constitutive activation of this pathway, often through mutations in key components like PIK3CA or loss of the tumor suppressor PTEN, allows cancer cells to evade apoptosis, sustain proliferation, and adapt to metabolic stress.[2][4]

Rupatasertib (formerly DIACC3010) is a potent, orally available small molecule inhibitor developed to strategically target this crucial oncogenic pathway.[5][6] Unlike many inhibitors that target a single node, Rupatasertib is a dual inhibitor of the serine/threonine protein kinases Akt (also known as Protein Kinase B) and the 70 kDa ribosomal protein S6 kinase (p70S6K).[5][6] This guide provides a technical overview of the PI3K/Akt/mTOR pathway, the unique mechanism of Rupatasertib, and the experimental methodologies used to validate its activity and therapeutic potential for researchers and drug development professionals.

The PI3K/Akt/mTOR Signaling Cascade: A Master Regulator of Cell Fate

The PI3K/Akt/mTOR pathway is a complex and tightly regulated network. Its activation typically begins at the cell surface with the stimulation of receptor tyrosine kinases (RTKs) by growth

factors or insulin.[7] This leads to the recruitment and activation of Class IA PI3Ks.

Key Components and Activation Flow:

- **PI3K Activation:** Activated PI3K phosphorylates phosphatidylinositol (4,5)-bisphosphate (PIP2) at the plasma membrane, converting it into the second messenger phosphatidylinositol (3,4,5)-trisphosphate (PIP3).[1]
- **Akt Recruitment and Activation:** PIP3 acts as a docking site for proteins with pleckstrin homology (PH) domains, including Akt and phosphoinositide-dependent kinase 1 (PDK1). This co-localization at the membrane facilitates the phosphorylation of Akt at Threonine 308 (Thr308) by PDK1 and at Serine 473 (Ser473) by the mTOR Complex 2 (mTORC2), leading to its full activation.[1]
- **Downstream Effectors:** Once activated, Akt phosphorylates a multitude of downstream substrates, orchestrating a pro-survival and pro-growth cellular program. A key downstream effector is the mTOR Complex 1 (mTORC1). Akt can relieve the inhibition of mTORC1 by phosphorylating and inactivating the tuberous sclerosis complex (TSC1/2).
- **mTORC1 and p70S6K:** Active mTORC1 then phosphorylates its own set of targets, most notably p70S6K and the eukaryotic translation initiation factor 4E-binding protein 1 (4E-BP1), to promote protein synthesis and cell growth.[2]

The tumor suppressor PTEN acts as a critical negative regulator of this pathway by dephosphorylating PIP3 back to PIP2, thus antagonizing PI3K activity.[4] Loss of PTEN function is a common event in many cancers, leading to hyperactivation of the pathway.[2]

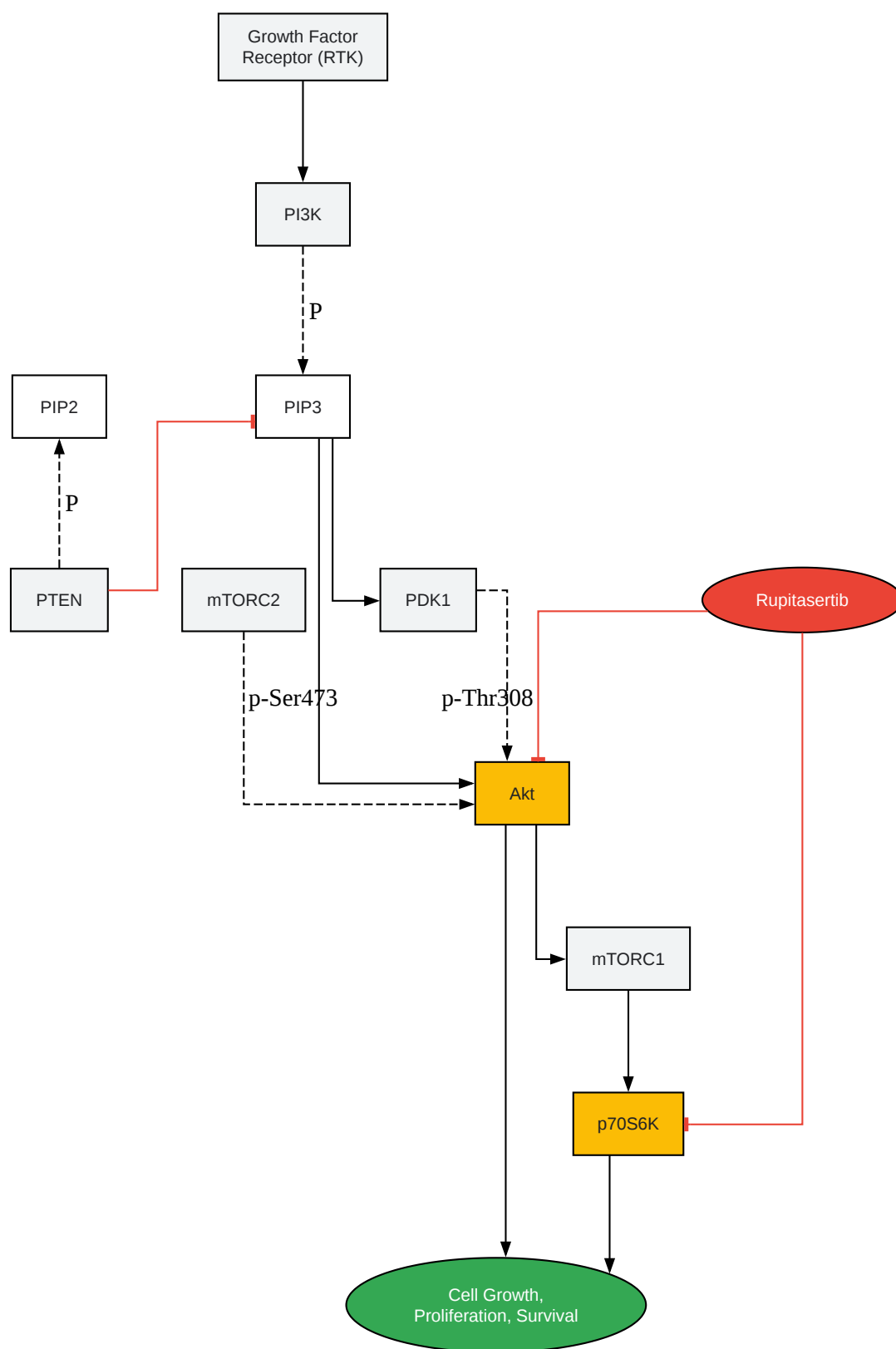

[Click to download full resolution via product page](#)

Caption: The PI3K/Akt/mTOR signaling pathway with points of inhibition by Rupitasertib.

Rupitasertib: A Strategic Dual-Node Inhibitor

Rupitasertib is an ATP-competitive inhibitor that potently targets both Akt (all three isoforms: AKT1/2/3) and p70S6K.[5][8] This dual-inhibition strategy is a key design feature intended to produce a more profound and durable blockade of the pathway compared to single-node inhibitors.

The Rationale for Dual Inhibition:

A significant challenge in targeting the PI3K/Akt/mTOR pathway is the presence of complex feedback loops.[9] For instance, inhibiting mTORC1 with rapalogs can lead to a feedback activation of Akt, which can attenuate the therapeutic effect.[9][10] By simultaneously inhibiting Akt and a key downstream effector, p70S6K, Rupitasertib is designed to prevent this compensatory feedback loop, leading to a more complete shutdown of downstream signaling required for tumor cell survival and proliferation.[11][12]

Preclinical studies have demonstrated that Rupitasertib effectively suppresses the phosphorylation of downstream signaling proteins like PRAS40 and GSK3 β . [8] This inhibition leads to dose-dependent reductions in proliferation and enhances markers of apoptosis across a range of cancer cell lines, including breast, ovarian, and prostate cancers.[8]

Preclinical Evaluation Workflow: A Multi-Faceted Approach

Validating a targeted inhibitor like Rupitasertib requires a systematic, multi-tiered experimental approach. The goal is to move from demonstrating direct target engagement in a cell-free system to confirming pathway modulation and, ultimately, functional cellular consequences.

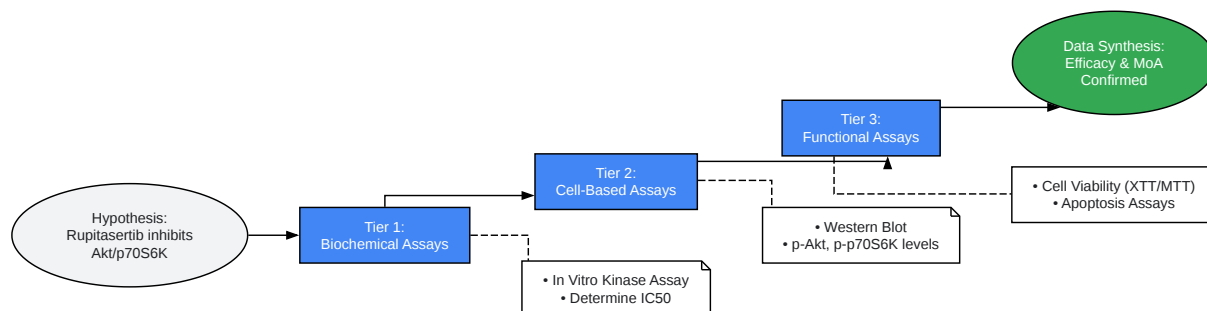

[Click to download full resolution via product page](#)

Caption: A tiered workflow for the preclinical validation of Rupitasertib.

Tier 1: Biochemical Kinase Assays

Causality: The first step is to prove that Rupitasertib directly inhibits the enzymatic activity of its intended targets, Akt and p70S6K, in a purified, cell-free system. This confirms on-target activity and allows for the determination of the inhibitor's potency, typically expressed as the half-maximal inhibitory concentration (IC50).

Protocol: In Vitro Kinase Activity Assay (Luminescent)

This protocol is based on the principle of quantifying the amount of ATP consumed during the kinase's phosphorylation of a substrate. The ADP-Glo™ Kinase Assay is a common example. [\[13\]](#)[\[14\]](#)

- Reagent Preparation:
 - Prepare a kinase reaction buffer (e.g., 50mM HEPES, pH 7.5; 50mM NaCl; 3mM MgCl₂; 0.025mg/ml BSA).[\[13\]](#)[\[14\]](#)
 - Prepare a serial dilution of Rupitasertib in DMSO, then dilute further in the kinase buffer. Include a DMSO-only vehicle control.

- Prepare a solution containing the purified kinase (e.g., recombinant human Akt1) and its specific substrate (e.g., a synthetic peptide) in the kinase buffer.
- Kinase Reaction:
 - In a 384-well plate, add 0.5 μL of the diluted Rupitasertib or vehicle control.[14]
 - Add 4 μL of the enzyme/substrate mixture to each well.[14]
 - Initiate the reaction by adding 0.5 μL of ATP solution (e.g., 250 μM).[14]
 - Incubate at room temperature for 60 minutes.[14]
- Signal Detection:
 - Add 5 μL of ADP-Glo™ Reagent to each well to terminate the kinase reaction and deplete the remaining ATP. Incubate for 40 minutes at room temperature.
 - Add 10 μL of Kinase Detection Reagent to convert the generated ADP back to ATP and provide the substrate (luciferin) for luciferase.
 - Incubate for 30 minutes at room temperature to stabilize the luminescent signal.
- Data Acquisition and Analysis:
 - Read the luminescence on a plate reader.
 - The luminescent signal is directly proportional to the amount of ADP formed and thus to kinase activity.
 - Plot the percentage of inhibition against the logarithm of the Rupitasertib concentration and fit the data to a dose-response curve to calculate the IC50 value.

Self-Validation: The inclusion of a no-enzyme control (background), a no-inhibitor control (maximum activity), and a vehicle control ensures that the observed effects are due to the compound and not the solvent.

Tier 2: Western Blotting for Pathway Modulation

Causality: After confirming direct enzyme inhibition, it is crucial to demonstrate that Rupitasertib can effectively engage its targets and suppress the signaling pathway within a living cell.

Western blotting is the gold-standard technique for this, as it allows for the direct visualization and quantification of the phosphorylation status of key pathway proteins. A reduction in the phosphorylated forms of Akt (p-Akt) and p70S6K's direct substrate, S6 ribosomal protein (p-S6), upon treatment provides direct evidence of pathway inhibition.

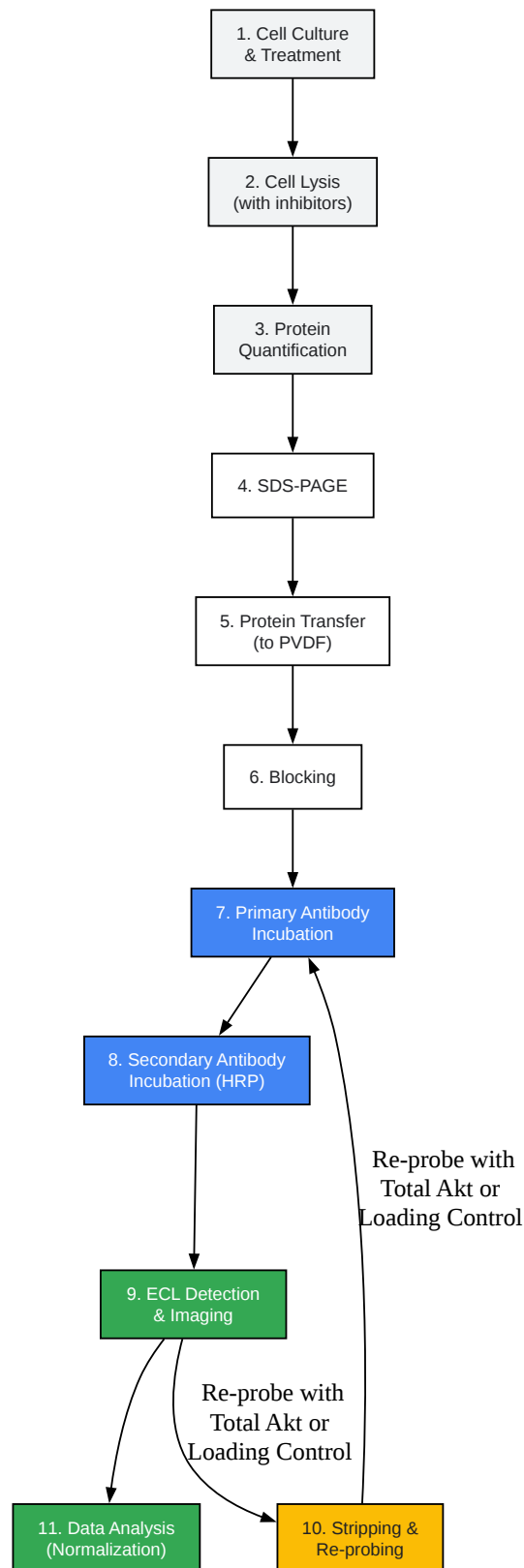

[Click to download full resolution via product page](#)

Caption: A standard workflow for Western Blot analysis of protein phosphorylation.

Protocol: Western Blot for p-Akt (Ser473) and Total Akt

- Cell Culture and Treatment:
 - Plate cancer cells (e.g., MCF-7 breast cancer cells) and allow them to adhere overnight.
 - Treat cells with varying concentrations of Rupitasertib for a predetermined time (e.g., 2-24 hours). Include a vehicle-only (DMSO) control.
 - For a positive control, you can stimulate the vehicle-treated cells with a growth factor like insulin (100 nM for 20 minutes) before harvesting to induce robust Akt phosphorylation.[1]
- Sample Preparation:
 - Place culture plates on ice and wash cells with ice-cold PBS.
 - Lyse the cells by adding ice-cold lysis buffer supplemented with a cocktail of protease and phosphatase inhibitors.[1][15] The use of phosphatase inhibitors is critical to preserve the phosphorylation state of the proteins.[15]
 - Centrifuge the lysates at high speed (e.g., 12,000 rpm) for 20 minutes at 4°C to pellet cell debris.[1]
 - Determine the protein concentration of the supernatant using a standard method (e.g., BCA assay).
- SDS-PAGE and Protein Transfer:
 - Normalize all samples to the same protein concentration, add Laemmli sample buffer, and boil at 95°C for 5 minutes.
 - Load equal amounts of protein (20-40 µg) per lane onto an SDS-PAGE gel.[1]
 - Perform electrophoresis to separate proteins by size.
 - Transfer the separated proteins from the gel to a PVDF or nitrocellulose membrane.[1]
- Immunoblotting:

- Block the membrane for 1 hour at room temperature using a blocking buffer such as 5% Bovine Serum Albumin (BSA) in Tris-Buffered Saline with Tween 20 (TBST).[1] Avoid using milk as a blocking agent, as its phosphoprotein (casein) content can cause high background.[15][16]
- Incubate the membrane overnight at 4°C with a primary antibody specific for phosphorylated Akt (e.g., anti-p-Akt Ser473) diluted in blocking buffer (e.g., 1:1000).[1]
- Wash the membrane three times with TBST.
- Incubate for 1 hour at room temperature with a horseradish peroxidase (HRP)-conjugated secondary antibody (e.g., anti-rabbit IgG) diluted in blocking buffer (e.g., 1:2000).[1]
- Detection and Analysis:
 - Wash the membrane again with TBST.
 - Apply an enhanced chemiluminescence (ECL) substrate and capture the signal using a digital imaging system.[1]
- Self-Validation (Normalization):
 - To ensure that any observed decrease in p-Akt is not due to differences in protein loading, the membrane must be stripped and re-probed with an antibody against total Akt.[1]
 - The intensity of the p-Akt band is then normalized to the intensity of the total Akt band for each sample. A loading control, such as β -actin or GAPDH, should also be used to confirm equal loading across all lanes.

Tier 3: Functional Cell-Based Assays

Causality: The ultimate goal of inhibiting the PI3K/Akt/mTOR pathway is to halt cancer cell proliferation and/or induce cell death. Therefore, it is essential to measure the functional consequences of Rupitasertib treatment. Cell viability assays are a high-throughput method to assess the compound's anti-proliferative or cytotoxic effects.

Comparison of Viability Assays

Assay	Principle	Advantages	Disadvantages
MTT	Mitochondrial dehydrogenases in viable cells reduce the yellow tetrazolium salt (MTT) to an insoluble purple formazan.[17][18]	Well-established, inexpensive.	Requires an additional solubilization step for the formazan crystals.[17]
XTT	Mitochondrial dehydrogenases reduce the XTT tetrazolium salt to a water-soluble orange formazan.[17][19]	Streamlined protocol (no solubilization step), higher sensitivity.[17]	Can be susceptible to interference from compounds affecting cellular redox potential.[17]

Protocol: XTT Cell Viability Assay

The XTT assay is often preferred for its simpler workflow.[17]

- Cell Seeding: Plate cancer cells in a 96-well microplate at a predetermined density and incubate for 24 hours to allow for attachment.
- Compound Treatment: Add a serial dilution of Rupitasertib to the wells. Include vehicle-only (DMSO) and no-cell (background) controls. Incubate for the desired treatment period (e.g., 72-96 hours).
- Reagent Preparation and Addition:
 - Prepare the activated XTT solution by mixing the XTT reagent and the electron-coupling reagent according to the manufacturer's instructions.[17]
 - Add 50 μ L of the activated XTT solution to each well.[17]
- Incubation: Incubate the plate for 2-4 hours at 37°C in a CO₂ incubator.[17] The incubation time may need optimization depending on the cell type and its metabolic rate.

- Data Acquisition:
 - Measure the absorbance of the wells at a wavelength between 450-500 nm using a microplate reader.[17]
 - A reference wavelength between 630-690 nm should be used to subtract background absorbance.[17]
- Data Analysis:
 - Subtract the background absorbance from all readings.
 - Calculate the percentage of cell viability for each concentration relative to the vehicle-treated control cells (which represent 100% viability).
 - Plot the percent viability against the logarithm of the Rupitasertib concentration to determine the GI50 (concentration for 50% growth inhibition) or IC50 value.

Clinical Development and Future Perspectives

Rupitasertib has been evaluated in a Phase 1 clinical trial in patients with various advanced solid tumors, where it demonstrated a favorable safety profile and preliminary signs of efficacy. [11][12] Based on these findings and compelling preclinical data, particularly in combination with other agents, Rupitasertib is being advanced into further clinical development.[11][12] A Phase 2 trial is planned to evaluate Rupitasertib in combination with elacestrant for patients with ER+/HER2- advanced breast cancer harboring ESR1 mutations.[11][12]

The strategic dual inhibition of Akt and p70S6K by Rupitasertib represents a promising approach to overcome the intrinsic resistance mechanisms that have limited the efficacy of other PI3K/Akt/mTOR pathway inhibitors.[11] Future research will likely focus on identifying predictive biomarkers to select patient populations most likely to benefit from this therapy and exploring rational combination strategies to further enhance its anti-tumor activity.

Conclusion

Rupitasertib is a novel dual inhibitor that potently and strategically targets the PI3K/Akt/mTOR pathway at two critical nodes. Its mechanism is designed to provide a more robust and

sustained inhibition of this oncogenic driver pathway by mitigating compensatory feedback loops. The validation of Rupitasertib's activity relies on a logical, multi-tiered approach, from direct biochemical assays to cellular pathway analysis and functional viability assessments. The detailed protocols and rationale provided in this guide offer a framework for researchers to effectively evaluate Rupitasertib and similar targeted inhibitors, ultimately advancing the development of more effective cancer therapies.

References

- A Comparative Guide: MTT vs. XTT Assays for Cell Viability - Benchchem.
- PI3K/Akt/mTOR Pathway and Its Role in Cancer Therapeutics: Are We Making Headway? - Frontiers.
- PI3K/AKT/mTOR p
- CyQUANT XTT and MTT Assays for Cell Viability | Thermo Fisher Scientific - TR.
- PI3K/Akt/mTOR signaling pathway in cancer stem cells: from basic research to clinical applic
- Cell Viability and Prolifer
- Rupitasertib | CAS#1379545-95-5 | p70S6K and Akt inhibitor - MedKoo Biosciences.
- Rupitasertib - New Drug Approvals.
- The Role of PI3K/AKT/mTOR Signaling in Tumor Radioresistance and Advances in Inhibitor Research - MDPI.
- Targeting PI3K/mTOR Signaling in Cancer - AACR Journals.
- Application Notes and Protocols for Western Blot Analysis of Akt Signaling Following Akt-IN-11 Tre
- Rupitasertib - Evexta Bio - AdisInsight.
- Evexta Bio Reports Progress towards Clinical Development of Rupitasertib in Advanced Breast Cancer - FirstWord Pharma.
- MTT assay - Wikipedia.
- Evexta Bio Reports Progress towards Clinical Development of Rupitasertib in Advanced Breast Cancer - BioSpace.
- Cell Viability Assays - Assay Guidance Manual - NCBI Bookshelf.
- PI3K(p110 β /p85 α)
- Cell-based assays for dissecting the PI3K/AKT pathway | Cancer Research - AACR Journals.
- Cellular Assays for Interrogating the PI3K/AKT/mTOR P
- Feedback from FDA following Type B meeting encourages clinical development of rupitasertib in advanced breast cancer - Onco-This-Week.
- PI3K(p110 α /p85 α)
- Tips to Optimize Your Western Blot for Phosphoryl

- Innovative clinical-stage biotech company - Evextabio.
- Measuring PI3K Lipid Kinase Activity | Springer N
- NEWS RELEASE Evexta Bio Reports Progress towards Clinical Development of Rupitasertib in Advanced Breast Cancer. [[Link](#)]
- Best Practice for Western Blot Detection of Phosphoryl
- Targeting the PI3K/AKT/mTOR Pathway: Biomarkers of Success and Tribul
- Enhanced Multiplex Western Blotting - Bio-Rad.
- Western blot analysis of Akt, p-Akt (Ser473), GSK β and p-GSK β (ser-9) protein expression.
- PI3K AKT mTOR P
- Inhibitors of PI3K/Akt/mTOR signaling are cytotoxic to T-ALL primary...
- Inhibition of the PI3K/AKT/mTOR P

Need Custom Synthesis?

BenchChem offers custom synthesis for rare earth carbides and specific isotopic labeling.

Email: info@benchchem.com or [Request Quote Online](#).

Sources

- 1. pdf.benchchem.com [pdf.benchchem.com]
- 2. [Frontiers | PI3K/Akt/mTOR Pathway and Its Role in Cancer Therapeutics: Are We Making Headway?](https://frontiersin.org) [frontiersin.org]
- 3. [PI3K/Akt/mTOR signaling pathway in cancer stem cells: from basic research to clinical application](https://pubmed.ncbi.nlm.nih.gov/) - PMC [[pmc.ncbi.nlm.nih.gov](https://pubmed.ncbi.nlm.nih.gov/)]
- 4. [PI3K/AKT/mTOR pathway](https://en.wikipedia.org) - Wikipedia [en.wikipedia.org]
- 5. newdrugapprovals.org [newdrugapprovals.org]
- 6. [Rupitasertib - Evexta Bio](https://adisinsight.springer.com) - AdisInsight [adisinsight.springer.com]
- 7. aacrjournals.org [aacrjournals.org]
- 8. medkoo.com [medkoo.com]
- 9. [PI3K AKT mTOR Pathway in Cancer - FineTest ELISA Kit | FineTest Antibody | FineTest®](https://fn-test.com) [fn-test.com]
- 10. ascopubs.org [ascopubs.org]

- [11. firstwordpharma.com](https://www.firstwordpharma.com) [[firstwordpharma.com](https://www.firstwordpharma.com)]
- [12. biospace.com](https://www.biospace.com) [[biospace.com](https://www.biospace.com)]
- [13. promega.com](https://www.promega.com) [[promega.com](https://www.promega.com)]
- [14. promega.de](https://www.promega.de) [[promega.de](https://www.promega.de)]
- [15. Tips for Western Blot of Phosphorylated Protein](https://www.novusbio.com) [[novusbio.com](https://www.novusbio.com)]
- [16. bio-rad-antibodies.com](https://www.bio-rad-antibodies.com) [[bio-rad-antibodies.com](https://www.bio-rad-antibodies.com)]
- [17. pdf.benchchem.com](https://www.pdf.benchchem.com) [[pdf.benchchem.com](https://www.pdf.benchchem.com)]
- [18. MTT assay - Wikipedia](https://en.wikipedia.org) [en.wikipedia.org]
- [19. CyQUANT XTT and MTT Assays for Cell Viability | Thermo Fisher Scientific - SG](https://www.thermofisher.com) [[thermofisher.com](https://www.thermofisher.com)]
- To cite this document: BenchChem. [Introduction: Targeting a Core Cancer Pathway]. BenchChem, [2026]. [Online PDF]. Available at: [<https://www.benchchem.com/product/b1191806/docs#introduction-targeting-a-core-cancer-pathway>]

Disclaimer & Data Validity:

The information provided in this document is for Research Use Only (RUO) and is strictly not intended for diagnostic or therapeutic procedures. While BenchChem strives to provide accurate protocols, we make no warranties, express or implied, regarding the fitness of this product for every specific experimental setup.

Technical Support: The protocols provided are for reference purposes. Unsure if this reagent suits your experiment?

Need Industrial/Bulk Grade? [Request Custom Synthesis Quote](#)

BenchChem

Our mission is to be the trusted global source of essential and advanced chemicals, empowering scientists and researchers to drive progress in science and industry.

Contact

Address: 3281 E Guasti Rd

Ontario, CA 91761, United States

Phone: (601) 213-4426

Email: info@benchchem.com

[Contact our Ph.D. Support Team for a compatibility check](#)