

Technical Guide: Structure, Properties, and Synthesis of Enzalutamide Intermediate B

Author: BenchChem Technical Support Team. **Date:** May 2026

Compound of Interest

Compound Name: 2-(5-Chloropyridin-2-yl)-2-methylpropanenitrile

Cat. No.: B11909213

[Get Quote](#)

Executive Summary

In the convergent synthesis of Enzalutamide (MDV3100), Intermediate B serves as the critical nucleophilic partner that reacts with the electrophilic isothiocyanate fragment (Intermediate A) to construct the thiohydantoin core. Chemically identified as 2-((3-fluoro-4-(methylcarbamoyl)phenyl)amino)-2-methylpropanoic acid (or its methyl ester derivative), this molecule dictates the regioselectivity of the final cyclization and introduces the essential dimethyl-substituted alpha-carbon that confers metabolic stability to the drug.

This guide analyzes the physicochemical properties, synthetic pathways, and quality control parameters for Intermediate B, providing researchers with a self-validating protocol for its generation and characterization.

Note on Nomenclature: While impurity profiling (e.g., pharmacopeial standards) sometimes designates the starting material 4-bromo-2-fluoro-N-methylbenzamide as "Impurity/Intermediate B," this guide focuses on the advanced coupling fragment (CAS 1289942-66-0 / 1332524-01-2) due to its higher complexity and critical role in the final API assembly.

Chemical Identity & Structural Analysis[1]

Identification Data

Parameter	Detail
Chemical Name	2-((3-fluoro-4-(methylcarbamoyl)phenyl)amino)-2-methylpropanoic acid
Common Aliases	Enzalutamide Amine Fragment; Intermediate 2; MDV-3100 Amine
CAS Number	1289942-66-0 (Acid form) 1332524-01-2 (Methyl ester form)
Molecular Formula	C ₁₂ H ₁₅ FN ₂ O ₃
Molecular Weight	254.26 g/mol (Acid)
SMILES	<chem>CNC(=O)c1ccc(cc1F)NC(C)(C)C(=O)O</chem>

Structural Features & Reactivity

- Gem-Dimethyl Group:** The sterically bulky gem-dimethyl group at the -position prevents metabolic hydrolysis and restricts the conformational freedom of the amino acid tail, favoring the subsequent cyclization step.
- Fluorine Substituent:** The ortho-fluorine atom on the phenyl ring exerts an inductive electron-withdrawing effect, modulating the nucleophilicity of the aniline nitrogen. This fine-tuning is crucial for preventing over-reaction while ensuring sufficient reactivity toward the isothiocyanate.
- Amide Moiety:** The N-methylbenzamide group is robust but susceptible to hydrolysis under strongly acidic/basic conditions, necessitating controlled pH environments during the Ullmann coupling step.

Synthetic Pathways & Causality

The synthesis of Intermediate B typically proceeds via a copper-catalyzed Ullmann-type coupling. This route is preferred over nucleophilic aromatic substitution (

) due to the weak electrophilicity of the unactivated aryl bromide.

Synthesis Workflow (Graphviz Diagram)

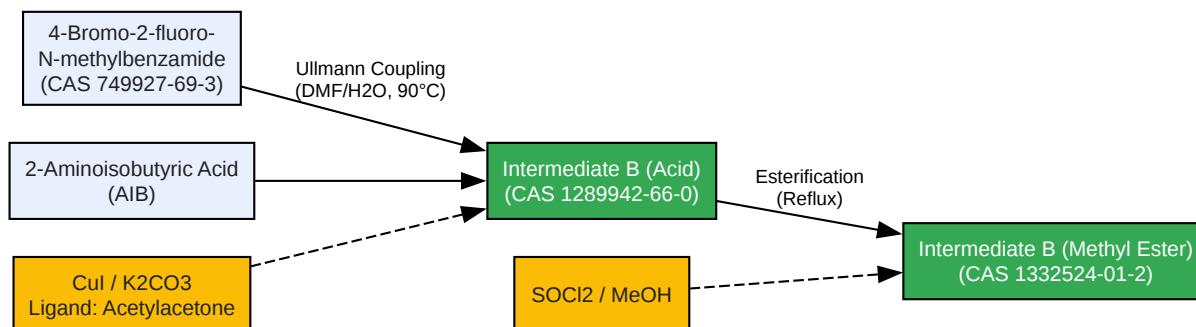

[Click to download full resolution via product page](#)

Figure 1: Synthetic route for Enzalutamide Intermediate B via Ullmann coupling and subsequent esterification.

Detailed Protocol: Ullmann Coupling

Objective: Couple 4-bromo-2-fluoro-N-methylbenzamide with 2-aminoisobutyric acid.

- **Reagent Setup:** Charge a reactor with 4-bromo-2-fluoro-N-methylbenzamide (1.0 eq), 2-aminoisobutyric acid (1.5 eq), and Potassium Carbonate (2.0 eq).
- **Catalytic System:** Add CuI (0.1 eq) and 2-acetylcyclohexanone or acetylacetone (0.2 eq) as the ligand. The ligand is essential to solubilize the copper species and stabilize the oxidative addition intermediate.
- **Solvent & Condition:** Use DMF/Water (9:1) to ensure solubility of the amino acid salt. Heat to 90–100°C for 12–16 hours.
 - **Causality:** Water is included to dissolve the inorganic base and amino acid, but excess water can stall the reaction; the 9:1 ratio is the optimal trade-off.

- Workup: Cool to room temperature. Acidify with 1N HCl to pH 3–4 to precipitate the product (Acid form). Filter and wash with water to remove inorganic salts and copper residues.

Physicochemical Properties[4][5]

Understanding the physical state of Intermediate B is vital for process handling.

Property	Value / Description
Appearance	Off-white to pale yellow crystalline solid
Melting Point	208 – 212 °C (Acid form)
Solubility	Soluble in DMSO, DMF, Methanol. Sparingly soluble in water (Acid form precipitates at low pH).
pKa	~3.8 (Carboxylic acid), ~2.5 (Aniline nitrogen - very weak base due to EWG)
Hygroscopicity	Low (crystalline form); Amorphous forms may be hygroscopic.

Analytical Characterization

HPLC Method for Purity & Impurities

A reverse-phase HPLC method is required to separate Intermediate B from the unreacted bromo-precursor and the des-fluoro impurities.

- Column: C18 (e.g., Agilent Zorbax Eclipse Plus), 150 x 4.6 mm, 3.5 µm.
- Mobile Phase A: 0.1% Phosphoric acid in Water.
- Mobile Phase B: Acetonitrile.
- Gradient: 10% B to 90% B over 20 minutes.
- Detection: UV at 235 nm (monitoring the benzamide chromophore).

Spectroscopic Profile

- ¹H NMR (DMSO-d₆, 400 MHz):
 - 12.5 (br s, 1H, COOH)
 - 8.2 (q, 1H, NH-Methyl)
 - 7.6 (t, 1H, Ar-H)
 - 6.5 (dd, 1H, Ar-H)
 - 6.3 (dd, 1H, Ar-H)
 - 2.7 (d, 3H, N-CH₃)
 - 1.4 (s, 6H, gem-dimethyl)
 - Interpretation: The distinct singlet at 1.4 ppm confirms the incorporation of the aminoisobutyric acid fragment.

Impurity Profiling & Fate Map

Control of Intermediate B purity is critical as impurities here can propagate to the final API, often forming difficult-to-remove analogs.

Key Impurities

Impurity Name	Structure/Origin	Risk Level
Impurity B1 (Starting Material)	4-bromo-2-fluoro-N-methylbenzamide	High (Competes in next step)
Impurity B2 (Des-fluoro)	Defluorinated analog formed via hydrodehalogenation during coupling	Medium (Genotoxic potential)
Impurity B3 (Dimer)	N,N-diaryl species formed if amine reacts twice	Low (Sterically hindered)

Impurity Fate Diagram (Graphviz)

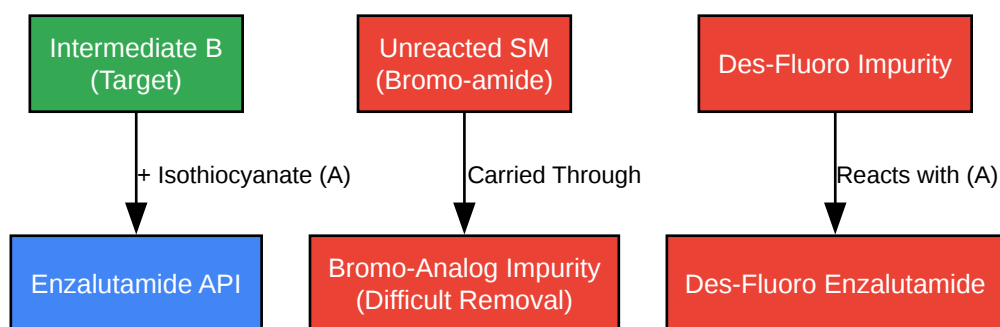

[Click to download full resolution via product page](#)

Figure 2: Fate map illustrating how impurities in Intermediate B propagate to the final Enzalutamide drug substance.

Handling & Safety (MSDS Highlights)

- Hazards: Intermediate B is an irritant (Skin/Eye).[1] The precursor (Bromo-amide) is potentially toxic.
- Storage: Store at 2–8°C under inert atmosphere (Argon/Nitrogen). The methyl ester form is more stable than the free acid, which can decarboxylate at elevated temperatures (>150°C).
- PPE: Standard lab coat, nitrile gloves, and safety glasses. Use a fume hood during the Ullmann coupling due to DMF vapors.

References

- Medivation, Inc. (2006). Diarylhydantoin compounds. US Patent 7,709,517. [Link](#)
- Sawant, R., et al. (2012). Process for the preparation of Enzalutamide. WO Patent 2014041487.[2] [Link](#)
- ChemicalBook. (2024). Product entry: 2-((3-fluoro-4-(methylcarbamoyl)phenyl)amino)-2-methylpropanoic acid (CAS 1289942-66-0).[3] [Link](#)
- PubChem. (2024). Compound Summary: Enzalutamide Intermediate B. [Link](#)
- BenchChem. (2025). Enzalutamide Synthesis Intermediates Technical Guide. [Link](#)

Need Custom Synthesis?

BenchChem offers custom synthesis for rare earth carbides and specific isotopic labeling.

Email: info@benchchem.com or [Request Quote Online](#).

Sources

- [1. 4-isothiocyanato-2-\(trifluoroMethyl\)benzonitrile | 143782-23-4 \[chemicalbook.com\]](#)
- [2. CN111386257A - Process for preparing enzalutamide using novel intermediates - Google Patents \[patents.google.com\]](#)
- [3. en.huatengsci.com \[en.huatengsci.com\]](#)
- To cite this document: BenchChem. [Technical Guide: Structure, Properties, and Synthesis of Enzalutamide Intermediate B]. BenchChem, [2026]. [Online PDF]. Available at: [\[https://www.benchchem.com/product/b11909213/docs#technical-guide-structure-properties-and-synthesis-of-enzalutamide-intermediate-b\]](https://www.benchchem.com/product/b11909213/docs#technical-guide-structure-properties-and-synthesis-of-enzalutamide-intermediate-b)

Disclaimer & Data Validity:

The information provided in this document is for Research Use Only (RUO) and is strictly not intended for diagnostic or therapeutic procedures. While BenchChem strives to provide accurate protocols, we make no warranties, express or implied, regarding the fitness of this product for every specific experimental setup.

Technical Support: The protocols provided are for reference purposes. Unsure if this reagent suits your experiment?

Need Industrial/Bulk Grade? [Request Custom Synthesis Quote](#)

BenchChem

Our mission is to be the trusted global source of essential and advanced chemicals, empowering scientists and researchers to drive progress in science and industry.

Contact

Address: 3281 E Guasti Rd

Ontario, CA 91761, United States

Phone: (601) 213-4426

Email: info@benchchem.com

[Contact our Ph.D. Support Team for a compatibility check](#)