

# Comprehensive Guide to Crystal Structure Analysis of 4,6-Dimethoxypyrimidin-2-yl Complexes

**Author:** BenchChem Technical Support Team. **Date:** April 2026

## Compound of Interest

Compound Name: (4,6-Dimethoxypyrimidin-2-yl)boronic acid

Cat. No.: B11908406

[Get Quote](#)

## Executive Summary & Strategic Importance

The 4,6-dimethoxypyrimidin-2-yl moiety is a pharmacophore of critical importance in medicinal chemistry and agrochemistry.[1] It serves as the bioactive core in a vast class of sulfonylurea herbicides (e.g., rimsulfuron, nicosulfuron) and is increasingly utilized in designing antimicrobial and anticancer agents.

For drug development professionals, understanding the solid-state architecture of these complexes is not merely academic—it is predictive.[1] The crystal packing determines solubility, bioavailability, and stability. This guide compares the structural performance of 4,6-dimethoxypyrimidin-2-yl complexes against their 4,6-dimethyl analogs, revealing how the methoxy group alters supramolecular assembly through unique hydrogen-bonding synthons and electronic modulation.[1]

## Structural Comparative Analysis: Methoxy vs. Methyl

The substitution of methyl groups with methoxy groups at the 4- and 6-positions of the pyrimidine ring induces profound changes in the crystal lattice.[1]

## Electronic and Steric Causality

- **Electronic Effect:** The methoxy group ( ) acts as a -withdrawing but -donating substituent.[1] In the solid state, this increases the electron density at the pyrimidine N1 and N3 nitrogens compared to the methyl analog, enhancing their capability as hydrogen bond acceptors.
- **Steric/Conformational Effect:** The methoxy groups introduce rotational degrees of freedom. Crystal structures reveal that the methyl groups of the methoxy moiety typically lie effectively in the plane of the pyrimidine ring (planar conformation) to maximize - conjugation, but they can deviate significantly to accommodate steric crowding in complex salts.

## Performance Comparison Table

Feature	4,6-Dimethoxy Complexes	4,6-Dimethyl Complexes	Impact on Drug Development
H-Bond Acceptors	High (Ring N + Methoxy O)	Moderate (Ring N only)	Methoxy O atoms enable auxiliary C-H...O interactions, stabilizing unique polymorphs.[1]
Solubility Profile	Generally Higher	Lower	Dimethoxy derivatives often show improved aqueous solubility due to increased polarity. [1]
Packing Motif	Shear-sliding Layers	Herringbone / Stacked	Layered structures in dimethoxy complexes often facilitate tablet compression.[1]
Synthon Stability	Forms robust R2 <sup>2</sup> (8) & R1 <sup>2</sup> (6) motifs	Forms R2 <sup>2</sup> (8)	Dimethoxy groups allow for more diverse heterosynthons with carboxylic acids.

## Experimental Protocol: Crystallization & Structure Solution

To obtain high-fidelity structural data, a self-validating workflow is required.[1] The following protocol minimizes disorder and twinning, common issues with pyrimidine derivatives.

### Workflow Visualization

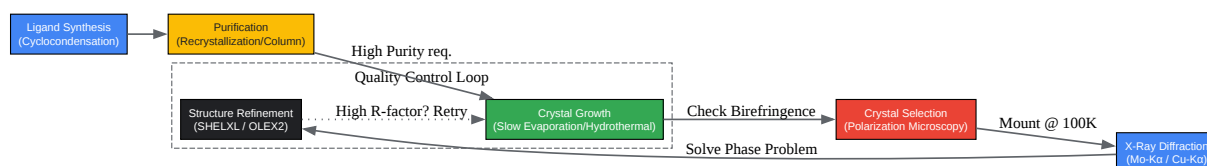

[Click to download full resolution via product page](#)

Figure 1: Optimized workflow for the structural determination of pyrimidine complexes. The feedback loop from Refinement to Growth is critical for resolving disorder in the methoxy groups.

## Detailed Methodology

- Synthesis & Purity:
  - Start with 2-amino-4,6-dimethoxypyrimidine.[1][2] Ensure purity >99% via HPLC. Impurities often poison crystal faces, leading to twinning.
  - Complexation: For metal complexes (e.g., Cu(II), Zn(II)), use a 1:1 or 1:2 stoichiometric ratio in methanol/water mixtures. For supramolecular salts (e.g., with carboxylic acids), use a 1:1 ratio in ethanol.
- Crystal Growth (The "Anti-Solvent" Technique):
  - Dissolve 0.1 mmol of the complex in a minimum amount of DMF or DMSO (good solvents).
  - Place this vial inside a larger jar containing ethanol or diethyl ether (anti-solvent).
  - Seal the outer jar. Vapor diffusion will slowly supersaturate the inner solution over 3-7 days.[1]

- Why this works: Direct evaporation often yields amorphous powder for these polar compounds. Vapor diffusion controls nucleation rates.[1]
- Data Collection:
  - Mount crystal on a MiTeGen loop using Paratone oil.
  - Temperature: Collect data at 100 K.
  - Reasoning: Methoxy groups often exhibit high thermal motion or rotational disorder at room temperature. Cooling freezes these conformations, allowing precise bond length determination.

## Key Structural Data & Supramolecular Synthons

The "performance" of these molecules in a biological context is often dictated by their ability to form specific hydrogen-bonded motifs (synthons).

### The R<sup>2</sup><sup>2</sup>(8) Homosynthon

In the absence of other strong donors, 2-amino-4,6-dimethoxypyrimidine derivatives self-assemble via the R<sup>2</sup><sup>2</sup>(8) motif.[1] Two molecules pair up through N-H...N hydrogen bonds involving the amino group and the ring nitrogen (N1 or N3).[2]

- Geometry: Centrosymmetric dimer.[1]
- Distance: N...N distances typically range 2.98 – 3.05 Å.[1]
- Relevance: This robust dimer mimics the base-pairing in DNA, explaining the biological affinity of these derivatives.[1]

### Heterosynthons in Salts

When co-crystallized with carboxylic acids (e.g., in salt selection for drug formulation), the proton transfer from acid to the pyrimidine ring nitrogen creates a charge-assisted hydrogen bond.

Interaction Type	Donor (D)	Acceptor (A)	Typical Distance (Å)	Stability Contribution
Charge-Assisted HB	Pyrimidinium N-H	Carboxylate O	2.60 – 2.75	Primary (Lattice Energy Dominant)
Auxiliary HB	Amino N-H	Carboxylate O	2.85 – 3.00	Secondary (Directional Steering)
Weak Interaction	C-H (Methoxy)	O (Sulfonyl/Nitro)	3.20 – 3.50	Fine-tuning (Polymorph selection)

## Supramolecular Architecture Diagram

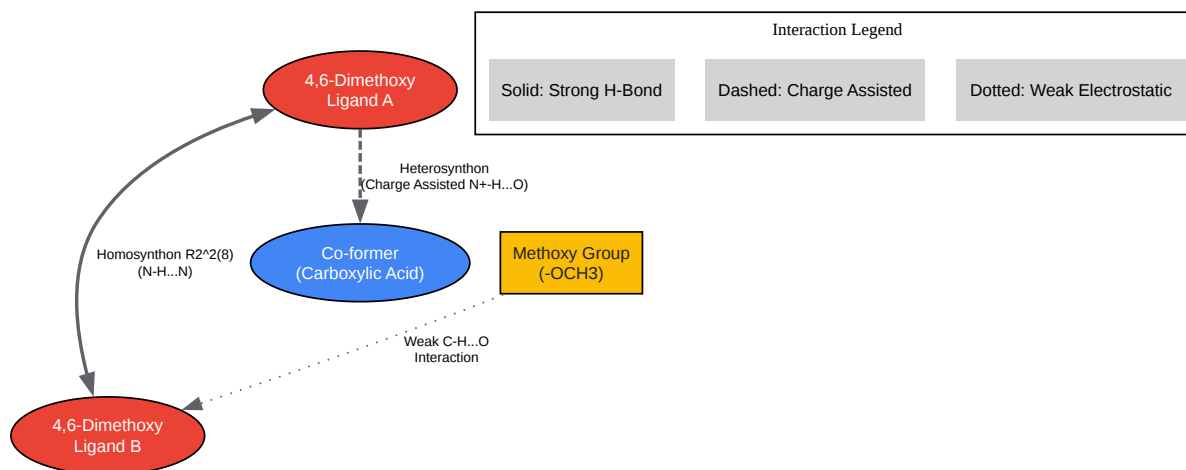

[Click to download full resolution via product page](#)

Figure 2: Schematic of competing supramolecular synthons. The methoxy group acts as a weak acceptor, influencing the 3D packing beyond the primary 2D sheets formed by strong

hydrogen bonds.

## Case Study: Sulfonylurea Herbicides

Reference Compound: 4,6-dimethoxy-2-(methylsulfonyl)pyrimidine<sup>[1][3][4]</sup>

In the crystal structure of sulfonylurea precursors, the orientation of the sulfonyl group relative to the pyrimidine ring is critical.

- Observation: The sulfonyl group often adopts a specific torsion angle to minimize repulsion with the lone pairs of the ring nitrogens and the methoxy oxygens.
- Data Point: In 4,6-dimethoxy-2-(methylsulfonyl)pyrimidine, the C-S-C-N torsion angle can vary significantly (e.g.,  $\sim 6^\circ$  vs  $\sim 158^\circ$ ) depending on the specific polymorph or cocrystal, indicating conformational flexibility.
- Implication: This flexibility allows the ligand to "mold" into the binding pockets of target enzymes (e.g., acetolactate synthase), explaining its high potency compared to rigid analogs.

## References

- Crystal structure of 2-(2-((4,6-dimethoxypyrimidin-2-yl)oxy)phenyl)-4-(piperidin-1-yl)-5H-chromeno[2,3-d]pyrimidine. (2024). Zeitschrift für Kristallographie - New Crystal Structures. [Link](#)
- The crystal structure of 5-chloro-4,6-dimethoxypyrimidin-2-amine. (2020). Zeitschrift für Kristallographie.<sup>[1][5]</sup> [Link](#)
- 4,6-Dimethoxy-2-(methylsulfonyl)pyrimidine. (2010).<sup>[1]</sup> Acta Crystallographica Section E. [Link](#)
- Synthesis, Crystal Structure and Supramolecular Features of Novel 2,4-Diaminopyrimidine Salts. (2024). MDPI - Crystals. [Link](#)
- Crystal structure of 2-amino-4,6-dimethoxypyrimidinium thiophene-2-carboxylate. (2015). IUCrData. [Link](#)

### Need Custom Synthesis?

BenchChem offers custom synthesis for rare earth carbides and specific isotopic labeling.

Email: [info@benchchem.com](mailto:info@benchchem.com) or [Request Quote Online](#).

## Sources

- [1. 2-Amino-4,6-dimethoxypyrimidine | C6H9N3O2 | CID 118946 - PubChem \[pubchem.ncbi.nlm.nih.gov\]](#)
- [2. researchgate.net \[researchgate.net\]](#)
- [3. 4,6-Dimethoxy-2-\(methylsulfonyl\)pyrimidine | C7H10N2O4S | CID 838363 - PubChem \[pubchem.ncbi.nlm.nih.gov\]](#)
- [4. 4,6-Dimethoxy-2-\(methylsulfonyl\)pyrimidine - PMC \[pmc.ncbi.nlm.nih.gov\]](#)
- [5. researchgate.net \[researchgate.net\]](#)
- To cite this document: BenchChem. [Comprehensive Guide to Crystal Structure Analysis of 4,6-Dimethoxypyrimidin-2-yl Complexes]. BenchChem, [2026]. [Online PDF]. Available at: [\[https://www.benchchem.com/product/b11908406/docs#comprehensive-guide-to-crystal-structure-analysis-of-4-6-dimethoxypyrimidin-2-yl-complexes\]](https://www.benchchem.com/product/b11908406/docs#comprehensive-guide-to-crystal-structure-analysis-of-4-6-dimethoxypyrimidin-2-yl-complexes)

---

### Disclaimer & Data Validity:

The information provided in this document is for Research Use Only (RUO) and is strictly not intended for diagnostic or therapeutic procedures. While BenchChem strives to provide accurate protocols, we make no warranties, express or implied, regarding the fitness of this product for every specific experimental setup.

**Technical Support:** The protocols provided are for reference purposes. Unsure if this reagent suits your experiment?

**Need Industrial/Bulk Grade?** [Request Custom Synthesis Quote](#)

# BenchChem

Our mission is to be the trusted global source of essential and advanced chemicals, empowering scientists and researchers to drive progress in science and industry.

## Contact

Address: 3281 E Guasti Rd

Ontario, CA 91761, United States

Phone: (601) 213-4426

Email: [info@benchchem.com](mailto:info@benchchem.com)

[Contact our Ph.D. Support Team for a compatibility check](#)