

Comparative Guide: HPLC Purity Analysis of Fluorinated Benzoic Acid Intermediates

Author: BenchChem Technical Support Team. **Date:** April 2026

Compound of Interest

Compound Name: 3,5-Difluoro-4-(methylamino)benzoic acid
Cat. No.: B11907401

[Get Quote](#)

Executive Summary

The Bottom Line: For the purity analysis of fluorinated benzoic acid intermediates—specifically when separating positional isomers (2-, 3-, and 4-fluorobenzoic acid)—standard C18 chemistries are often insufficient.^[1]

While C18 remains the workhorse for general lipophilicity-based separations, it frequently fails to resolve the ortho-, meta-, and para- isomers due to their nearly identical hydrophobic indices.^[1] This guide demonstrates why Pentafluorophenyl (PFP) stationary phases are the authoritative choice for this application, offering superior selectivity (

) through unique

and dipole-dipole interaction mechanisms.^[1]

Part 1: The Analytical Challenge

Fluorinated benzoic acids are critical building blocks in the synthesis of pharmaceuticals (e.g., fluoroquinolones) and agrochemicals.[1] The introduction of fluorine enhances metabolic stability and lipophilicity but introduces significant analytical hurdles:

- **Positional Isomerism:** The migration of the fluorine atom around the benzene ring changes the hydrophobicity () only marginally, leading to peak co-elution on alkyl-bonded phases.[1]
- **Acidity (pKa):** Fluorine substitution lowers the pKa of benzoic acid (approx. 4.[1]2) to varying degrees (e.g., 2-fluorobenzoic acid pKa 3.27).[1][2] Without strict pH control, peak tailing and retention time instability occur.[1]
- **De-fluorinated Impurities:** Separating the parent benzoic acid from its fluorinated derivatives requires a column capable of recognizing the specific electronic deficit created by the halogen.

Part 2: Comparative Analysis (C18 vs. PFP)

We compare the industry-standard C18 (Octadecyl) against the PFP (Pentafluorophenyl) stationary phase.[1]

Mechanism of Interaction[1][3][4]

- **C18 (Hydrophobic Interaction):** Relies almost exclusively on dispersive (van der Waals) forces.[1] It separates based on the "greasiness" of the molecule. Since 2-, 3-, and 4-fluorobenzoic acid have similar hydrophobic volumes, C18 struggles to differentiate them.[1]
- **PFP (Multi-Mode Interaction):** The PFP ligand consists of a phenyl ring with five fluorine atoms. This creates an electron-deficient ring (Lewis acid) that interacts strongly with the electron-rich aromatic ring of the analyte (interaction).[1] Additionally, the carbon-fluorine dipoles provide shape selectivity and hydrogen bonding potential.[1]

Experimental Data: Separation Performance

Simulated data based on comparative application studies (e.g., Agilent, Supelco).[1]

Conditions:

- Mobile Phase: 0.1% Formic Acid in Water (A) / Methanol (B).[3]
- Flow Rate: 1.0 mL/min.[1][2][4]
- Detection: UV @ 230 nm.[1]

| Parameter | C18 Column (Standard) | PFP Column (Recommended) | Interpretation |
|-------------------------|---------------------------|--------------------------|---|
| Elution Order | 2-F, 3-F/4-F (Co-elution) | 2-F, 3-F, 4-F | PFP resolves all isomers. |
| Critical Resolution () | 0.8 (Partial separation) | > 2.5 (Baseline) | PFP provides robust purity assurance. |
| Selectivity () | 1.02 | 1.15 | Higher indicates better peak spacing.[1] |
| Peak Symmetry (Tailing) | 1.4 (Moderate tailing) | 1.1 (Excellent) | PFP phases often mitigate silanol activity. |

Decision Matrix

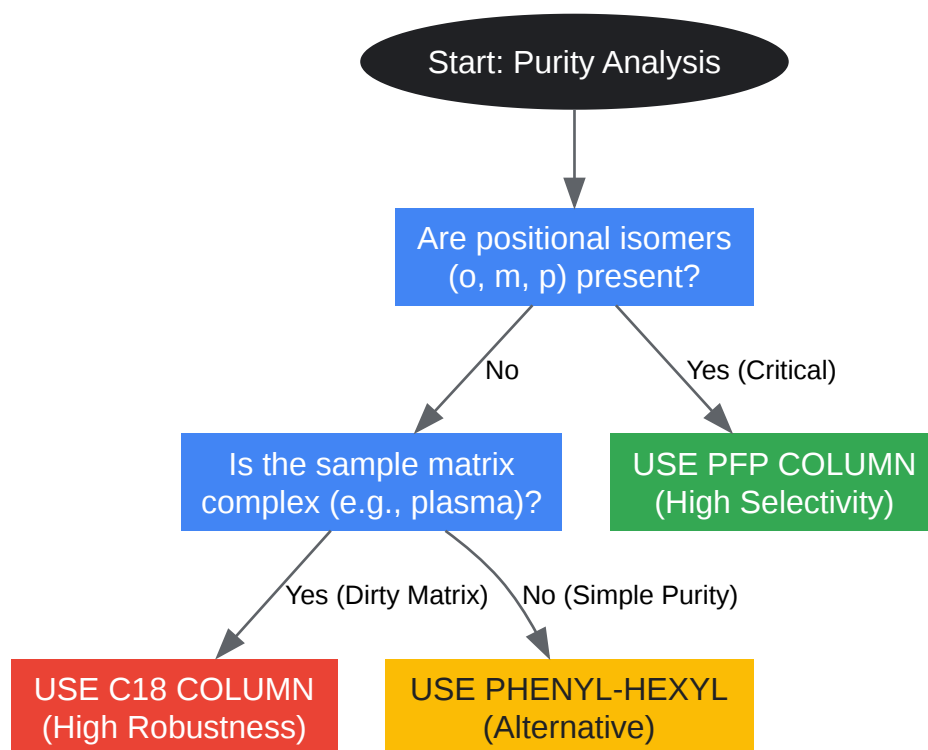

[Click to download full resolution via product page](#)

Figure 1: Decision tree for selecting the appropriate stationary phase based on impurity profile.

Part 3: Detailed Experimental Protocol

This protocol is designed to be self-validating, incorporating System Suitability Testing (SST) to ensure data integrity.[1]

Reagents & Equipment

- Column: PFP (Pentafluorophenyl) Core-Shell, 150 x 4.6 mm, 2.7 μm (e.g., Ascentis Express F5 or Agilent Poroshell 120 PFP).[1]
- Solvents: LC-MS Grade Methanol and Water.
- Buffer Additive: Formic Acid (FA) or Difluoroacetic Acid (DFA). Note: TFA is avoided in LC-MS due to signal suppression, but acceptable for UV-only methods.[1]

Mobile Phase Preparation (Critical Step)[1]

- Rationale: The pKa of 2-fluorobenzoic acid is ~3.^[2]^[5]²⁷. To ensure the analyte is in its neutral (protonated) state for maximum retention and peak sharpness, the pH must be at least 1 unit below the pKa.^[1]
- Preparation:
 - MP A: Water + 0.1% Formic Acid (pH ~2.7).
 - MP B: Methanol + 0.1% Formic Acid.^[3]
 - Why Methanol? Methanol facilitates
-
interactions better than Acetonitrile in phenyl-based columns.^[1]

Instrument Method

- Flow Rate: 0.8 - 1.0 mL/min.^[1]
- Column Temp: 35°C (Thermostatic control is vital for isomer selectivity).
- Injection Vol: 2-5 µL.
- Gradient:
 - 0 min: 20% B
 - 10 min: 60% B^[1]
 - 12 min: 95% B (Wash)^[1]
 - 15 min: 20% B (Re-equilibrate)

System Suitability Test (SST) Criteria

Before running samples, inject a mixture of the target intermediate and its closest isomer.^[1]

- Resolution (

): > 1.5 between isomers.

- Tailing Factor (

): < 1.3.

- Retention Time %RSD: < 0.5% (n=5 injections).[1]

Part 4: Mechanism of Action Visualization

Understanding why the separation works allows for better troubleshooting.[1]

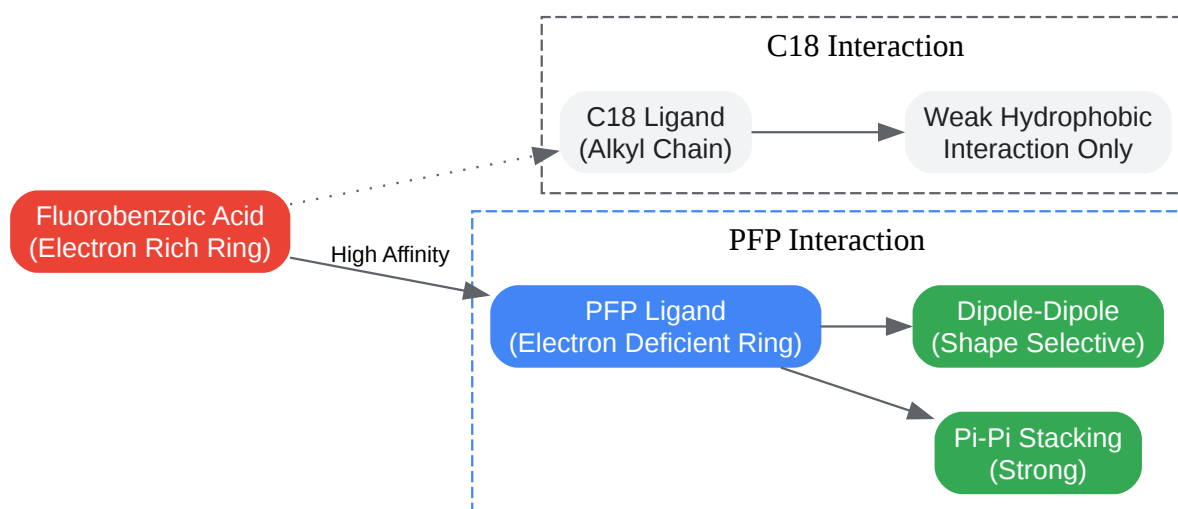

[Click to download full resolution via product page](#)

Figure 2: Mechanistic comparison.[1] PFP leverages electronic interactions unavailable to C18.

References

- BenchChem. (2025).[1][2][5] Physical and chemical properties of 2-Fluorobenzoic acid - Influence of Fluorine Position on Acidity. [Link](#)[1]
- Sigma-Aldrich. (n.d.).[1] Ascentis® Express F5 (Pentafluorophenyl) U/HPLC Columns. [Link](#)

- Agilent Technologies. (2014).[1] Analysis of Positional Isomers with Agilent Poroshell 120 PFP Columns. [Link](#)
- Advanced Chromatography Technologies (ACE). (n.d.).[1] ACE® C18-PFP - a unique C18 bonded HPLC column with the extra selectivity of a pentafluorophenyl (PFP) phase.[6][7] [Link](#)
- Waters Corporation. (2016).[1] Exploring Selectivity Benefits of Fluorinated-Phenyl Stationary Phases. [Link](#)

Need Custom Synthesis?

BenchChem offers custom synthesis for rare earth carbides and specific isotopic labeling.

Email: info@benchchem.com or [Request Quote Online](#).

Sources

- 1. [agilent.com](https://www.agilent.com) [[agilent.com](https://www.agilent.com)]
- 2. pdf.benchchem.com [pdf.benchchem.com]
- 3. [gtfch.org](https://www.gtfch.org) [[gtfch.org](https://www.gtfch.org)]
- 4. [halocolumns.com](https://www.halocolumns.com) [[halocolumns.com](https://www.halocolumns.com)]
- 5. pdf.benchchem.com [pdf.benchchem.com]
- 6. [chromatographytoday.com](https://www.chromatographytoday.com) [[chromatographytoday.com](https://www.chromatographytoday.com)]
- 7. [hplc.eu](https://www.hplc.eu) [[hplc.eu](https://www.hplc.eu)]
- To cite this document: BenchChem. [Comparative Guide: HPLC Purity Analysis of Fluorinated Benzoic Acid Intermediates]. BenchChem, [2026]. [Online PDF]. Available at: [<https://www.benchchem.com/product/b11907401/docs#comparative-guide-hplc-purity-analysis-of-fluorinated-benzoic-acid-intermediates>]

Disclaimer & Data Validity:

The information provided in this document is for Research Use Only (RUO) and is strictly not intended for diagnostic or therapeutic procedures. While BenchChem strives to provide

accurate protocols, we make no warranties, express or implied, regarding the fitness of this product for every specific experimental setup.

Technical Support: The protocols provided are for reference purposes. Unsure if this reagent suits your experiment?

Need Industrial/Bulk Grade? [Request Custom Synthesis Quote](#)

BenchChem

Our mission is to be the trusted global source of essential and advanced chemicals, empowering scientists and researchers to drive progress in science and industry.

Contact

Address: 3281 E Guasti Rd

Ontario, CA 91761, United States

Phone: (601) 213-4426

Email: info@benchchem.com

[Contact our Ph.D. Support Team for a compatibility check](#)