

Application Notes and Protocols for Metal Ion Detection Using Aminonaphthalene Derivatives

Author: BenchChem Technical Support Team. **Date:** April 2026

Compound of Interest

Compound Name: 1-Aminonaphthalene-6-acetonitrile

CAS No.: 1261595-80-5

Cat. No.: B11907891

[Get Quote](#)

A. Introduction

This document provides detailed application notes and experimental protocols for the use of aminonaphthalene derivatives as chemosensors for metal ion detection. While a specific search for "**1-Aminonaphthalene-6-acetonitrile** derivatives" did not yield established applications for metal ion sensing, this guide focuses on two closely related and well-documented classes of aminonaphthalene-based sensors: a poly(1-aminonaphthalene) system for the detection of Iron (III) ions (Fe^{3+}) and a naphthalene-derived Schiff base for the detection of Zinc (II) ions (Zn^{2+}).

These examples serve as a practical guide for researchers, scientists, and drug development professionals interested in the design and application of naphthalene-based fluorescent and colorimetric probes for metal ion analysis.

B. Application Note 1: Poly(1-aminonaphthalene) as a Colorimetric and Fluorescent Sensor for Fe^{3+}

1. Principle and Signaling Pathway

Poly(1-aminonaphthalene) serves as a selective chemosensor for Fe^{3+} ions through both colorimetric and fluorescence "turn-off" mechanisms. The polymer, which is purple and fluorescent, interacts with Fe^{3+} , leading to a visible color change to yellow and a significant quenching of its fluorescence emission[1]. The sensing mechanism is attributed to the coordination of Fe^{3+} with the amine groups on the polymer backbone, which facilitates an electron transfer process from the excited state of the fluorophore to the d-orbitals of the Fe^{3+} ion, resulting in non-radiative decay and fluorescence quenching.

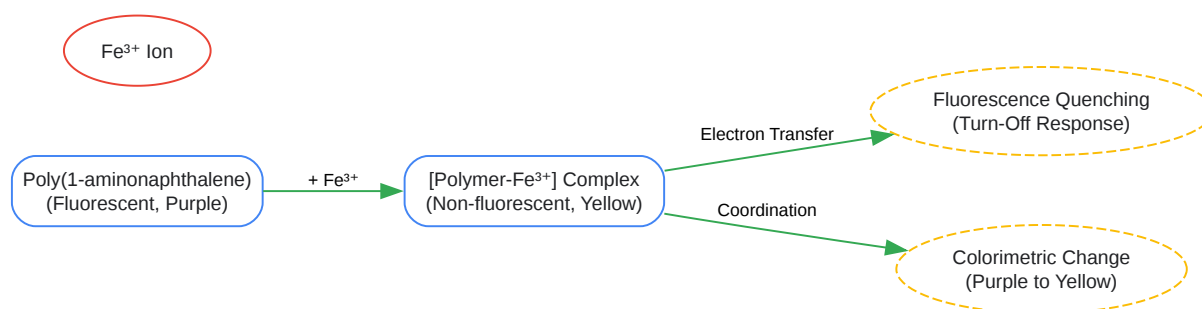

[Click to download full resolution via product page](#)

Caption: Signaling pathway for Fe^{3+} detection by poly(1-aminonaphthalene).

2. Quantitative Data

The performance of the poly(1-aminonaphthalene) sensor for Fe^{3+} detection is summarized in the table below.

Parameter	Value	Reference
Detection Method	Colorimetric & Fluorescent	[1]
Selectivity	High for Fe^{3+}	[1]
Linear Range	10 - 50 mg L ⁻¹	[1]
Limit of Detection (LOD)	1.04 mg L ⁻¹	[1]
Response Type	Fluorescence "Turn-Off"	[1]

3. Experimental Protocols

- Protocol 1: Synthesis of Poly(1-aminonaphthalene)

This protocol describes the chemical oxidative polymerization of 1-aminonaphthalene.

- Materials:

- 1-Aminonaphthalene
- Ferric chloride (FeCl_3) (as catalyst)
- Appropriate solvent (e.g., acetonitrile)
- Stirring apparatus
- Reaction vessel

- Procedure:

- Dissolve 1-aminonaphthalene in the chosen solvent in the reaction vessel.
- While stirring, add a solution of FeCl_3 catalyst to the monomer solution.
- Continue stirring at room temperature for a specified period to allow polymerization to occur.
- Precipitate the polymer by adding a non-solvent.
- Collect the polymer precipitate by filtration.
- Wash the polymer thoroughly to remove any unreacted monomer and catalyst.
- Dry the purified poly(1-aminonaphthalene) under vacuum.

- Protocol 2: Fe^{3+} Detection Assay

This protocol outlines the procedure for both colorimetric and fluorimetric detection of Fe^{3+} .

- Materials:
 - Stock solution of poly(1-aminonaphthalene) in a suitable solvent.
 - A series of standard solutions of Fe^{3+} of known concentrations.
 - Water samples for analysis.
 - UV-Vis spectrophotometer.
 - Fluorimeter.
- Procedure:
 - Prepare a series of vials containing the poly(1-aminonaphthalene) solution.
 - To each vial, add a different concentration of the Fe^{3+} standard solution or the water sample.
 - For colorimetric detection, observe the color change by the naked eye and measure the absorbance spectrum using a UV-Vis spectrophotometer.
 - For fluorimetric detection, excite the solution at the appropriate wavelength and record the fluorescence emission spectrum.
 - A decrease in fluorescence intensity indicates the presence of Fe^{3+} .
 - Construct a calibration curve by plotting the fluorescence intensity against the Fe^{3+} concentration to determine the concentration in unknown samples.

C. Application Note 2: Naphthalene-Derived Schiff Base as a "Turn-On" Fluorescent Sensor for Zn^{2+}

1. Principle and Signaling Pathway

Naphthalene-derived Schiff bases can act as highly selective "turn-on" fluorescent sensors for Zn^{2+} . In the free state, the Schiff base exhibits weak fluorescence due to processes like photoinduced electron transfer (PET) or C=N isomerization. Upon binding of Zn^{2+} to the Schiff

base, a rigid complex is formed. This chelation inhibits the non-radiative decay pathways, leading to a significant enhancement of fluorescence, a phenomenon known as chelation-enhanced fluorescence (CHEF)[2][3].

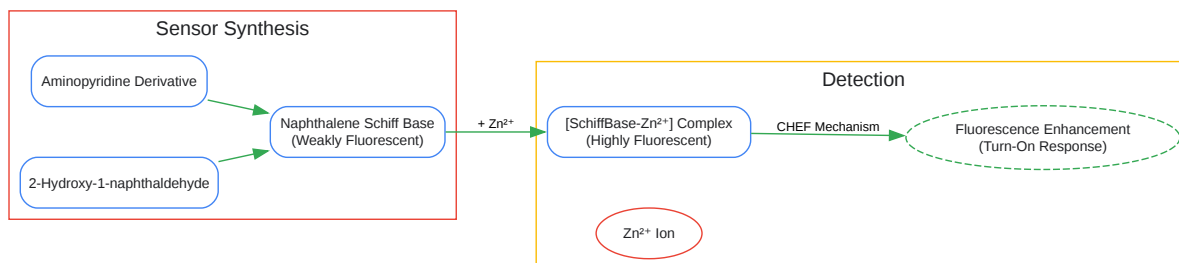

[Click to download full resolution via product page](#)

Caption: Experimental workflow for Zn²⁺ detection using a naphthalene Schiff base.

2. Quantitative Data

The performance characteristics of a representative naphthalene-derived Schiff base sensor for Zn²⁺ are detailed below.

Parameter	Value	Reference
Sensor (Example)	1-((pyridin-2-ylmethylimino)methyl)naphthalen-2-ol (NS)	[2]
Detection Method	Fluorescent	[2]
Selectivity	High for Zn ²⁺ over other ions like Cd ²⁺	[2]
Association Constant (K _a)	7.88 × 10 ⁶ M ⁻¹	[2]
Limit of Detection (LOD)	1.91 × 10 ⁻⁶ M	[2]
Response Type	Fluorescence "Turn-On" (10-fold enhancement)	[2]
Stoichiometry (Sensor:Zn ²⁺)	1:1	[4]

3. Experimental Protocols

- Protocol 3: Synthesis of Naphthalene-Derived Schiff Base (e.g., NS)

This protocol describes the condensation reaction to form the Schiff base.

- Materials:

- 2-Hydroxy-1-naphthaldehyde
- 2-(Aminomethyl)pyridine
- Ethanol (or other suitable solvent)
- Reflux apparatus
- Stirring apparatus

- Procedure:

- Dissolve 2-hydroxy-1-naphthaldehyde in ethanol in a round-bottom flask.

- Add an equimolar amount of 2-(aminomethyl)pyridine to the solution.
- Reflux the mixture with stirring for several hours.
- Monitor the reaction progress by thin-layer chromatography (TLC).
- After completion, cool the reaction mixture to room temperature.
- Collect the precipitated product by filtration.
- Recrystallize the product from a suitable solvent to obtain the pure Schiff base.
- Characterize the product using techniques such as NMR and mass spectrometry.

- Protocol 4: Zn²⁺ Detection Assay

This protocol details the fluorimetric titration for the detection of Zn²⁺.

- Materials:

- Stock solution of the naphthalene Schiff base sensor in a suitable solvent (e.g., aqueous solution).
- A series of standard solutions of Zn²⁺ of known concentrations.
- Solutions of other metal ions for selectivity studies.
- Fluorimeter.

- Procedure:

- Place a specific volume of the sensor stock solution into a cuvette.
- Record the initial fluorescence spectrum.
- Incrementally add small aliquots of the Zn²⁺ standard solution to the cuvette.
- After each addition, mix thoroughly and record the fluorescence emission spectrum (e.g., excitation at 352 nm, emission at 446 nm for NS)[2].

- Observe the increase in fluorescence intensity.
- Plot the fluorescence intensity as a function of Zn^{2+} concentration to determine the linear range and detection limit.
- To assess selectivity, repeat the experiment with other metal ions instead of Zn^{2+} and compare the fluorescence response.

Need Custom Synthesis?

BenchChem offers custom synthesis for rare earth carbides and specific isotopic labeling.

Email: info@benchchem.com or [Request Quote Online](#).

References

- [1. An aminonaphthalene-based colorimetric and fluorescent sensor for selective recognition of \$Fe^{3+}\$ in water - PubMed \[pubmed.ncbi.nlm.nih.gov\]](#)
- [2. A facile fluorescent chemosensor based on naphthalene-derived Schiff base for zinc ions in aqueous solution - Analytical Methods \(RSC Publishing\) \[pubs.rsc.org\]](#)
- [3. A fluorescent chemosensor based on naphthol for detection of \$Zn\(2\)\$ - PubMed \[pubmed.ncbi.nlm.nih.gov\]](#)
- [4. tandfonline.com \[tandfonline.com\]](#)
- To cite this document: BenchChem. [Application Notes and Protocols for Metal Ion Detection Using Aminonaphthalene Derivatives]. BenchChem, [2026]. [Online PDF]. Available at: [\[https://www.benchchem.com/product/b11907891/docs#application-notes-and-protocols-for-metal-ion-detection-using-aminonaphthalene-derivatives\]](https://www.benchchem.com/product/b11907891/docs#application-notes-and-protocols-for-metal-ion-detection-using-aminonaphthalene-derivatives)

Disclaimer & Data Validity:

The information provided in this document is for Research Use Only (RUO) and is strictly not intended for diagnostic or therapeutic procedures. While BenchChem strives to provide accurate protocols, we make no warranties, express or implied, regarding the fitness of this product for every specific experimental setup.

Technical Support: The protocols provided are for reference purposes. Unsure if this reagent suits your experiment?

Need Industrial/Bulk Grade? [Request Custom Synthesis Quote](#)

BenchChem

Our mission is to be the trusted global source of essential and advanced chemicals, empowering scientists and researchers to drive progress in science and industry.

Contact

Address: 3281 E Guasti Rd
Ontario, CA 91761, United States
Phone: (601) 213-4426
Email: info@benchchem.com

[Contact our Ph.D. Support Team for a compatibility check](#)