

Technical Comparison Guide: Mass Spectrometry Fragmentation of 5-Chloro-6-methoxyquinoline

Author: BenchChem Technical Support Team. **Date:** May 2026

Compound of Interest

Compound Name: 5-Chloro-6-methoxyquinoline

Cat. No.: B11904789

[Get Quote](#)

Executive Summary

5-Chloro-6-methoxyquinoline exhibits a distinct fragmentation signature driven by the lability of the 6-methoxy substituent and the isotopic stability of the 5-chloro group.^[1] Unlike its 8-methoxy isomers, which display a characteristic "M-3" hydrogen loss, the 6-methoxy variant primarily degrades via sequential losses of methyl radicals (

) and carbon monoxide (CO). This guide delineates these pathways to establish a robust identification protocol.

Core Chemical Specifications

Feature	Specification
Formula	
Exact Mass ()	193.0294 Da
Exact Mass ()	195.0265 Da
Isotope Pattern	~3:1 ()
Ionization Mode	ESI(+) / EI (70 eV)

Deep Dive: Fragmentation Mechanism

The "performance" of this molecule in an MS setting is defined by its predictable fragmentation tree, which allows for high-confidence structural assignment.

Primary Fragmentation Pathway (EI/ESI)

Upon ionization, the molecular ion (

in EI or

in ESI) undergoes a cascade of eliminations. The presence of the Chlorine atom provides an internal isotopic standard, tracking the fragment ions until the Cl atom itself is ejected.

- Step 1: Activation of the Methoxy Group The most energetically favorable pathway involves the cleavage of the ether bond at the 6-position.
 - Mechanism: Homolytic cleavage (EI) or neutral loss (ESI) of the methyl group.
 - Result: Loss of 15 Da ().
 - Diagnostic Value: High. This produces a base peak (or near base peak) at

178 (

).

- Step 2: Carbonyl Elimination Following methyl loss, the resulting quinolone-like cation undergoes ring contraction or rearrangement to expel carbon monoxide.

- Result: Loss of 28 Da (CO).[2]

- Fragment Mass:

150 (

).

- Step 3: Skeletal Degradation The pyridine ring of the quinoline backbone typically fragments via the loss of Hydrogen Cyanide (HCN).

- Result: Loss of 27 Da (HCN).

- Fragment Mass:

123 (

).

Visualization of Signaling Pathway

The following diagram illustrates the fragmentation logic, explicitly tracking the chlorine isotope retention.

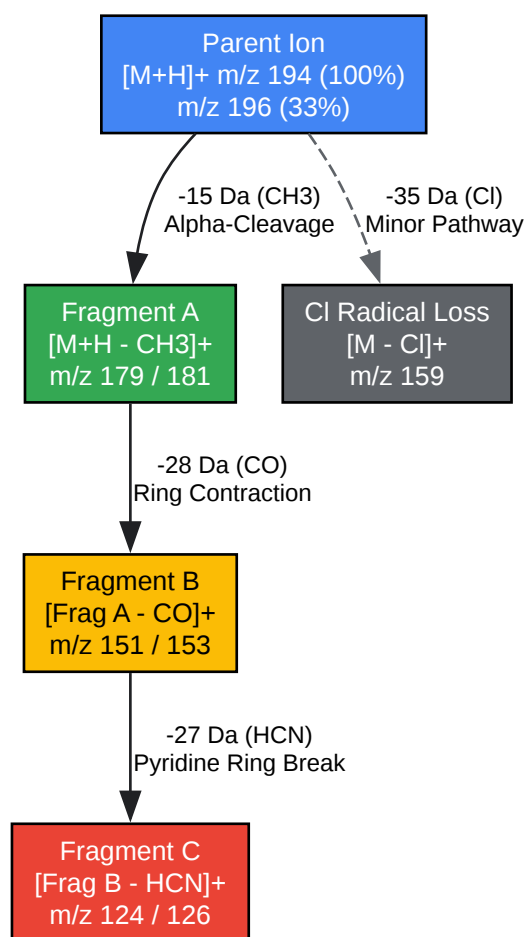

[Click to download full resolution via product page](#)

Figure 1: Step-wise fragmentation pathway of **5-Chloro-6-methoxyquinoline** in ESI(+) mode.

Comparative Analysis: Product vs. Alternatives

Distinguishing **5-Chloro-6-methoxyquinoline** from its isomers is the primary analytical challenge.^[1] The table below compares its performance against key alternatives.

Differentiating Isomers

The position of the methoxy group significantly alters the fragmentation kinetics.

Compound	Diagnostic Feature	Mechanism	Reference
5-Chloro-6-methoxyquinoline	Loss of (-15)	Cleavage of 6-OMe is the dominant primary channel.[1]	[1]
5-Chloro-8-methoxyquinoline	Loss of (-3)	"Ortho-effect" unique to 8-OMe; interaction with ring Nitrogen allows loss of 3 Hydrogens.	[1]
4-Chloro-6-methoxyquinoline	Cl Lability	4-Cl is more labile (nucleophilic susceptibility) than 5-Cl, leading to higher relative abundance of [M-Cl] ions.[1]	[2]

Decision Tree for Identification

Use this logic flow to validate the identity of the compound in a mixture.

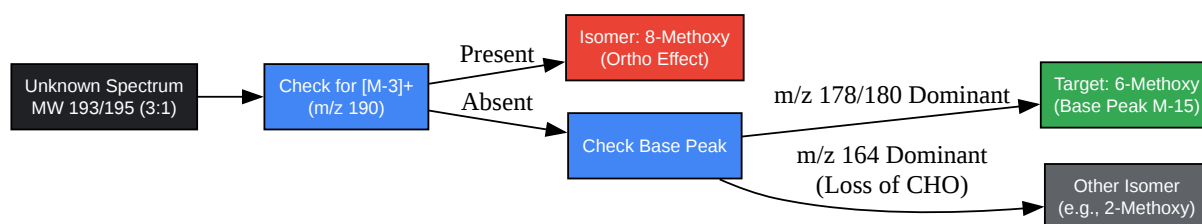

[Click to download full resolution via product page](#)

Figure 2: Logical decision tree for distinguishing methoxyquinoline isomers.

Experimental Protocol

To reproduce the fragmentation patterns described, the following protocol is recommended. This workflow ensures self-validation through the observation of the Chlorine isotope cluster.

Sample Preparation[1]

- Stock Solution: Dissolve 1 mg of **5-Chloro-6-methoxyquinoline** in 1 mL of Methanol (HPLC grade).
- Working Solution: Dilute to 1 µg/mL in 50:50 Methanol:Water with 0.1% Formic Acid (for ESI).

MS Parameters (Orbitrap/Q-TOF)[1]

- Ion Source: ESI Positive Mode.
- Capillary Voltage: 3.5 kV.
- Collision Energy (CID): Stepped energy ramp (15, 30, 45 eV) to capture the full fragmentation tree.
 - Rationale: Low energy preserves the molecular ion (194); high energy reveals the skeletal fragments (124).
- Scan Range:
50–300.

Validation Criteria

For a positive ID, the spectrum must meet these criteria:

- Parent Ion:
194.04 (approx) with a 3:1 ratio to
196.04.

- Primary Fragment:

179.01 (Loss of Methyl).

- Absence: No significant peak at

191 (M-3), ruling out the 8-methoxy isomer [1].[1]

References

- Clugston, D. M., & MacLean, D. B. (1966). Mass Spectra of Oxygenated Quinolines. Canadian Journal of Chemistry. Retrieved from [\[Link\]](#)
- Ribeiro, R. C., et al. (2024). Characterization of the fragmentation mechanisms in electrospray ionization tandem mass spectrometry of chloroquinoline derivatives. Rapid Communications in Mass Spectrometry. Retrieved from [\[Link\]](#)
- ChemGuide. (2025). Fragmentation Patterns in Mass Spectra. ChemGuide UK. Retrieved from [\[Link\]](#)

Need Custom Synthesis?

BenchChem offers custom synthesis for rare earth carbides and specific isotopic labeling.

Email: info@benchchem.com or [Request Quote Online](#).

Sources

- 1. [1803607-03-5|5-Chloro-6-methoxy-2-methylquinoline hydrochloride|BLD Pharm \[bldpharm.com\]](#)
- 2. [mdpi.com \[mdpi.com\]](#)
- To cite this document: BenchChem. [Technical Comparison Guide: Mass Spectrometry Fragmentation of 5-Chloro-6-methoxyquinoline]. BenchChem, [2026]. [Online PDF]. Available at: [\[https://www.benchchem.com/product/b11904789/docs#technical-comparison-guide-mass-spectrometry-fragmentation-of-5-chloro-6-methoxyquinoline\]](https://www.benchchem.com/product/b11904789/docs#technical-comparison-guide-mass-spectrometry-fragmentation-of-5-chloro-6-methoxyquinoline)

Disclaimer & Data Validity:

The information provided in this document is for Research Use Only (RUO) and is strictly not intended for diagnostic or therapeutic procedures. While BenchChem strives to provide accurate protocols, we make no warranties, express or implied, regarding the fitness of this product for every specific experimental setup.

Technical Support: The protocols provided are for reference purposes. Unsure if this reagent suits your experiment?

Need Industrial/Bulk Grade? [Request Custom Synthesis Quote](#)

BenchChem

Our mission is to be the trusted global source of essential and advanced chemicals, empowering scientists and researchers to drive progress in science and industry.

Contact

Address: 3281 E Guasti Rd
Ontario, CA 91761, United States
Phone: (601) 213-4426
Email: info@benchchem.com

[Contact our Ph.D. Support Team for a compatibility check](#)