

# Diethoxy(phenyl)silane: A Versatile Derivatizing Agent for Enhanced Gas Chromatographic Analysis

**Author:** BenchChem Technical Support Team. **Date:** April 2026

## Compound of Interest

Compound Name: *diethoxy(phenyl)silane*

Cat. No.: *B11901893*

[Get Quote](#)

## Introduction: The Imperative of Derivatization in Modern GC Analysis

In the landscape of analytical chemistry, particularly within pharmaceutical research and drug development, gas chromatography (GC) stands as a cornerstone for the separation and quantification of volatile and semi-volatile compounds.[1][2] However, the applicability of GC is often challenged by analytes bearing polar functional groups, such as hydroxyls (-OH), carboxylic acids (-COOH), and amines (-NH<sub>2</sub>). These moieties can lead to poor chromatographic performance, characterized by peak tailing, reduced sensitivity, and even thermal degradation in the high-temperature environment of the GC inlet and column.[1]

Chemical derivatization presents a powerful solution to these challenges. By chemically modifying the analyte to replace active hydrogens with less polar, more stable functional groups, we can significantly enhance its volatility and thermal stability.[2] Silylation, the introduction of a silyl group, is arguably the most prevalent and versatile derivatization technique in the GC analyst's toolkit.[3] This application note provides an in-depth technical guide to the use of a promising, yet less commonly documented, silylating agent:

**diethoxy(phenyl)silane.** We will explore its underlying reaction mechanisms, provide detailed experimental protocols, and discuss its potential applications, particularly in the analysis of pharmaceutical compounds.

## The Chemistry of Diethoxy(phenyl)silane

### Derivatization: A Mechanistic Overview

**Diethoxy(phenyl)silane** ((C<sub>2</sub>H<sub>5</sub>O)<sub>2</sub>SiH(C<sub>6</sub>H<sub>5</sub>)) belongs to the class of organosilanes. Its utility as a derivatizing agent stems from the reactivity of the silicon-ethoxy bonds, which can readily react with active hydrogens in polar functional groups to form stable silyl ethers, esters, and amines. The presence of the phenyl group on the silicon atom can confer increased thermal stability to the resulting derivatives compared to their trimethylsilyl (TMS) counterparts.

The general mechanism of silylation with **diethoxy(phenyl)silane** proceeds via a nucleophilic attack of the heteroatom (oxygen, nitrogen) of the analyte's functional group on the silicon atom. This results in the displacement of an ethoxy group, which then abstracts a proton to form ethanol as a byproduct. The reaction can be catalyzed by the presence of a mild base or an acid, which can activate the analyte or the silylating agent, respectively.

### Reaction with Hydroxyl Groups (Alcohols and Phenols)

Alcohols and phenols are excellent candidates for derivatization with **diethoxy(phenyl)silane**. The lone pair of electrons on the oxygen atom initiates the nucleophilic attack on the silicon center. The resulting phenyldiethoxysilyl ether is significantly more volatile and less polar than the parent alcohol or phenol.

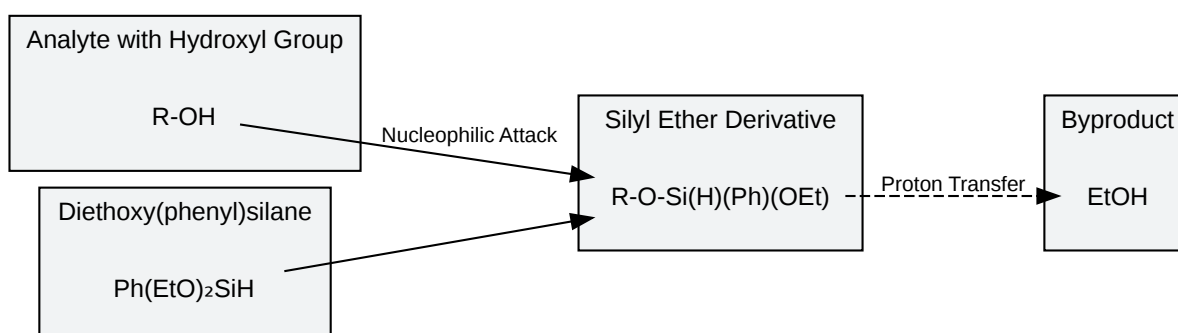

[Click to download full resolution via product page](#)

Caption: Silylation of a hydroxyl group with **diethoxy(phenyl)silane**.

## Reaction with Carboxylic Acids

Carboxylic acids react with **diethoxy(phenyl)silane** to form silyl esters. This transformation is crucial for the GC analysis of many acidic drugs and their metabolites. The derivatization masks both the polar hydroxyl and the carbonyl functionalities, significantly increasing volatility.

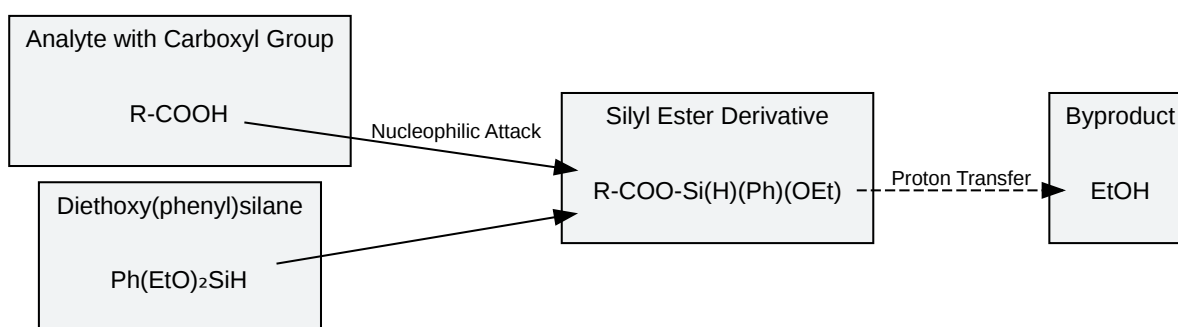

[Click to download full resolution via product page](#)

Caption: Silylation of a carboxylic acid with **diethoxy(phenyl)silane**.

## Reaction with Amines

Primary and secondary amines can also be derivatized with **diethoxy(phenyl)silane** to form N-silyl derivatives. This is particularly beneficial for the analysis of amphetamines, sympathomimetic amines, and other amine-containing pharmaceuticals. The resulting silylamines exhibit improved chromatographic behavior and reduced adsorption on the analytical column.

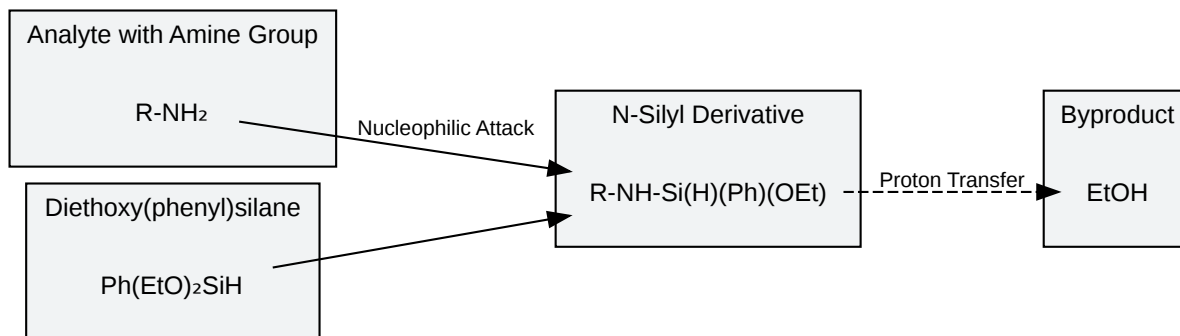

[Click to download full resolution via product page](#)

Caption: Silylation of a primary amine with **diethoxy(phenyl)silane**.

## Advantages of Diethoxy(phenyl)silane as a Derivatizing Agent

While a plethora of silylating agents exist, **diethoxy(phenyl)silane** offers a unique combination of properties that make it an attractive choice for specific applications:

Feature	Advantage	Rationale
Derivative Stability	Enhanced thermal and hydrolytic stability of the phenyl-silyl derivatives compared to TMS derivatives.	The phenyl group provides steric hindrance and electronic effects that strengthen the Si-O or Si-N bond.
Selective Reactivity	Potential for selective derivatization of more reactive functional groups (e.g., primary alcohols) in the presence of less reactive ones (e.g., hindered secondary or tertiary alcohols).	The ethoxy leaving groups are less reactive than the trifluoroacetamide leaving groups in reagents like BSTFA or MSTFA.
Favorable Byproducts	The primary byproduct is ethanol, which is relatively benign and easily separated chromatographically.	This contrasts with the acidic byproducts generated by chlorosilane reagents, which can potentially degrade sensitive analytes or the GC column.
Unique Mass Spectral Fragmentation	The phenyl group can direct fragmentation pathways in mass spectrometry, potentially providing more structural information for analyte identification.	The presence of the aromatic ring can lead to characteristic fragment ions, aiding in spectral interpretation.

## Experimental Protocol: A General Guideline for Derivatization

The following protocol provides a general framework for the derivatization of polar analytes using **diethoxy(phenyl)silane**. It is crucial to note that optimal conditions (e.g., temperature, reaction time, and reagent ratios) should be determined empirically for each specific analyte.

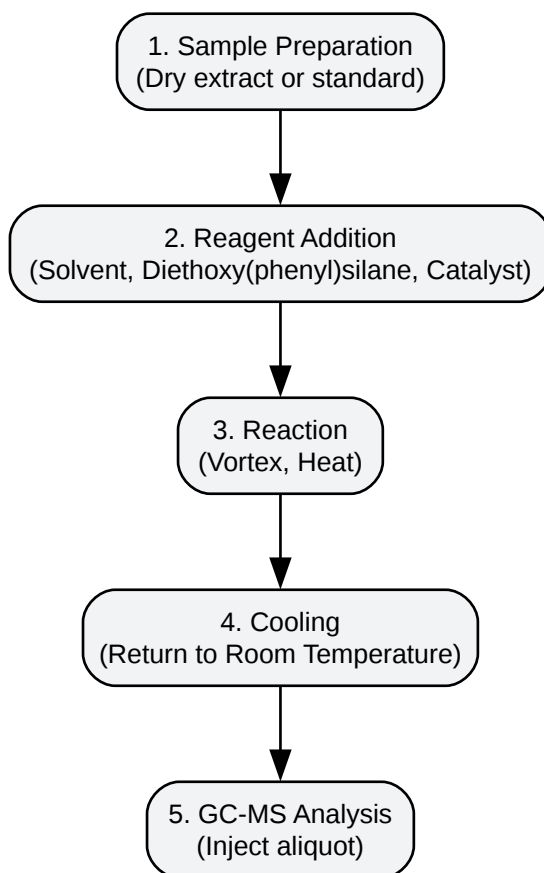

[Click to download full resolution via product page](#)

### Need Custom Synthesis?

BenchChem offers custom synthesis for rare earth carbides and specific isotopic labeling.

Email: [info@benchchem.com](mailto:info@benchchem.com) or [Request Quote Online](#).

## Sources

- [1. jfd-online.com](http://jfd-online.com) [jfd-online.com]
- [2. scispace.com](http://scispace.com) [scispace.com]
- [3. obrnutafaza.hr](http://obrnutafaza.hr) [obrnutafaza.hr]
- To cite this document: BenchChem. [Diethoxy(phenyl)silane: A Versatile Derivatizing Agent for Enhanced Gas Chromatographic Analysis]. BenchChem, [2026]. [Online PDF]. Available at: [<https://www.benchchem.com/product/b11901893/docs#diethoxy-phenyl-silane-a-versatile-derivatizing-agent-for-enhanced-gas-chromatographic-analysis>]

**Disclaimer & Data Validity:**

The information provided in this document is for Research Use Only (RUO) and is strictly not intended for diagnostic or therapeutic procedures. While BenchChem strives to provide accurate protocols, we make no warranties, express or implied, regarding the fitness of this product for every specific experimental setup.

**Technical Support:** The protocols provided are for reference purposes. Unsure if this reagent suits your experiment?

**Need Industrial/Bulk Grade?** [Request Custom Synthesis Quote](#)

## BenchChem

Our mission is to be the trusted global source of essential and advanced chemicals, empowering scientists and researchers to drive progress in science and industry.

### Contact

Address: 3281 E Guasti Rd  
Ontario, CA 91761, United States  
Phone: (601) 213-4426  
Email: [info@benchchem.com](mailto:info@benchchem.com)

[Contact our Ph.D. Support Team for a compatibility check](#)