

The Causality of Matrix Mismatch: Comparing Analytical Standards

Author: BenchChem Technical Support Team. **Date:** April 2026

Compound of Interest

Compound Name: 3-(1-Aziridinyl)-6-(methylsulfonyl)pyridazine
CAS No.: 90000-77-4
Cat. No.: B11900447

[Get Quote](#)

In CHNS analysis, the instrument's Thermal Conductivity Detector (TCD) relies on calibration curves generated from highly pure reference standards. A common critical error is using easily combustible aliphatic sulfur standards (like Methionine) to calibrate for highly stable aromatic sulfur heterocycles. This matrix mismatch leads to differing combustion kinetics and systematic under-reporting of sulfur.

To ensure accurate quantification, the analytical standard must structurally mimic the target analyte.

Table 1: Comparative Performance of CHNS Sulfur Standards

Standard	Molecular Formula	S% (Theoretical)	Structural Core	Matrix Match for Heterocycles	Combustion Volatility
BBOT	C ₂₆ H ₂₆ N ₂ O ₂ S	7.44%	Thiophene	Optimal	Low (Stable)
Sulfanilamide	C ₆ H ₈ N ₂ O ₂ S	18.62%	Sulfonamide	Moderate	Moderate
Methionine	C ₅ H ₁₁ NO ₂ S	21.49%	Aliphatic Thioether	Poor	High (Easily oxidized)

Why BBOT is the Gold Standard: BBOT (2,5-Bis(5-tert-butyl-benzoxazol-2-yl)thiophene) is a NIST-traceable standard uniquely suited for heterocyclic analysis[1]. Because its sulfur atom is embedded within a stable thiophene ring, its combustion profile precisely mimics the thermal resistance of complex pharmaceutical heterocycles[2]. Calibrating with BBOT ensures that the integration parameters and K-factors applied to the TCD signal account for the delayed release and oxidation of ring-bound sulfur. Sulfanilamide serves as an excellent secondary Quality Control (QC) check to validate the calibration[2].

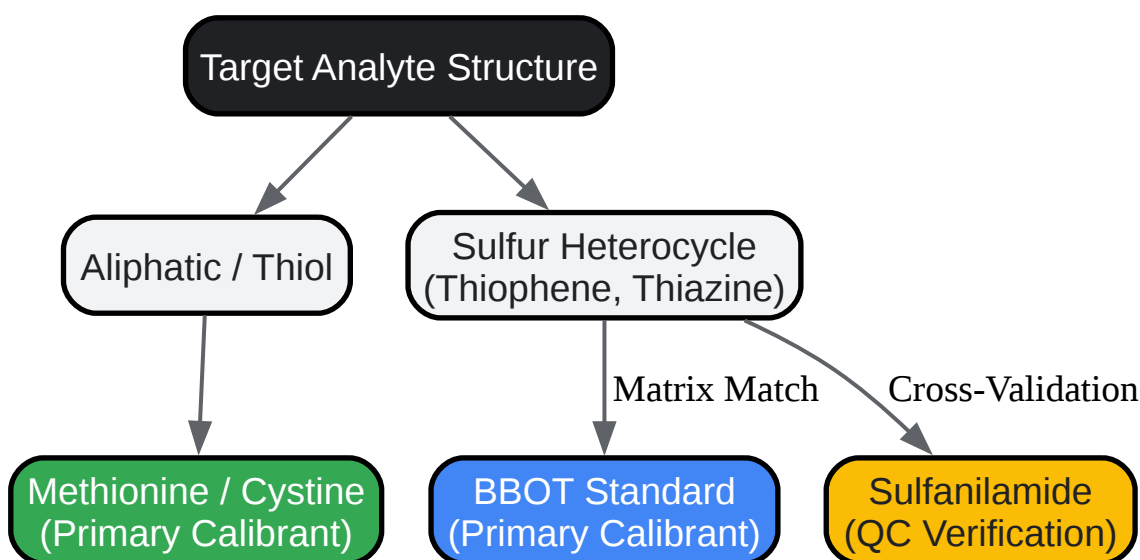

[Click to download full resolution via product page](#)

Decision logic for selecting CHNS calibration standards based on analyte structure.

Overcoming the SO₂/SO₃ Equilibrium: The Role of Combustion Catalysts

When a tin capsule containing the sample is dropped into the combustion reactor, an exothermic reaction with injected oxygen flashes the temperature to approximately 1800 °C[3]. While this easily oxidizes carbon and hydrogen, sulfur oxidation is complex. Without intervention, a fraction of the sulfur oxidizes to SO₃, which can be permanently trapped in the instrument's water trap or react with the copper reduction reactor, leading to low sulfur recovery.

Vanadium Pentoxide (V₂O₅) vs. Tungstic Oxide (WO₃) To force the quantitative conversion of all sulfur species exclusively to SO₂, a combustion catalyst must be added directly to the sample capsule.

- V₂O₅ (Recommended): Acts as a highly aggressive, localized oxygen donor. The addition of 5–10 mg of V₂O₅ to the tin capsule ensures the complete conversion of complex heterocyclic sulfur into SO₂[4]. It is particularly effective because it melts at a relatively low temperature (690 °C), coating the sample and driving oxidation during the initial flash phase.
- WO₃: While effective for general organic combustion, it requires higher temperatures to become active and is less efficient at preventing SO₃ formation in highly stable thiophenes compared to V₂O₅.

Self-Validating Experimental Protocol for Heterocyclic CHNS

To guarantee trustworthiness in your data, the analytical sequence must be designed as a self-validating system. This means the protocol inherently checks for baseline drift, calibration accuracy, and complete combustion.

Step-by-Step Methodology:

- System Blank Preparation: Weigh 3 empty tin capsules. To each, add exactly 10 mg of V₂O₅ catalyst. Causality: This establishes the baseline signal, accounting for any trace atmospheric nitrogen or sulfur impurities within the catalyst itself[5].

- Calibration (K-Factor Determination): Accurately weigh 2.0 to 3.0 mg of BBOT standard into 3 separate tin capsules. Add 10 mg of V_2O_5 to each[1]. Run these to establish the K-factor calibration curve for C, H, N, and S.
- QC Verification (Accuracy Check): Weigh 2.0 mg of Sulfanilamide + 10 mg V_2O_5 . Run as an unknown sample. The calculated values must fall within $\pm 0.3\%$ of the theoretical values (C: 41.84%, H: 4.68%, N: 16.27%, S: 18.62%)[6]. If it fails, the reduction reactor may be exhausted, or the GC column is compromised.
- Sample Preparation: Weigh 1.5 to 2.5 mg of the unknown sulfur heterocycle into a tin capsule. Immediately add 10 mg of V_2O_5 and seal tightly to exclude atmospheric moisture.
- Drift Monitoring: Insert a BBOT standard every 10–12 unknown samples to monitor and correct for baseline drift caused by ash buildup in the combustion crucible.

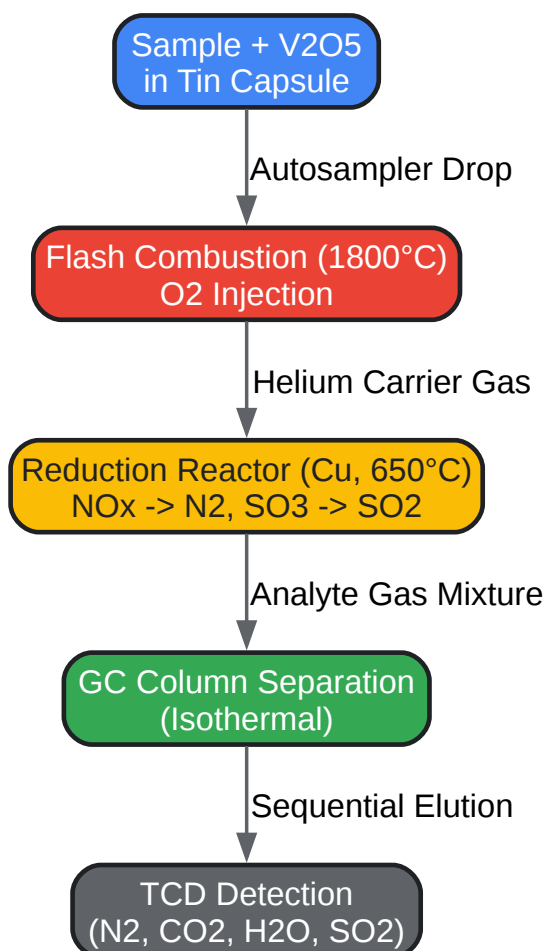

[Click to download full resolution via product page](#)

Mechanistic workflow of CHNS analysis utilizing V_2O_5 for complete sulfur conversion.

Conclusion

The accurate elemental analysis of sulfur-containing heterocycles cannot be treated as a routine push-button operation. By aligning the thermal properties of the calibration standard (BBOT) with the target analyte and manipulating the oxidation thermodynamics using Vanadium Pentoxide (V_2O_5), researchers can eliminate the systematic errors inherent to heterocyclic combustion.

References

1.[3] Just Agriculture. "Elemental Analyzer (CHNS) - Sulfur Analysis and Theory of Operation." Just Agriculture. Available at: 2.[5] Scribd. "CHNS Analyzer User Guide | Quality Control and Calibration Verification." International Ocean Discovery Program. Available at: 3.[1] Thermo Fisher Scientific. "Elemental analysis: CHNS/O characterization of particulate matter in water and air." Application Note 42305. Available at: 4.[6] Thermo Fisher Scientific. "Fully Automated Double Channel Analysis for CHNS Determination by TCD Detector and Trace Sulfur by FPD Detector." Available at: 5.[2] RSC Publishing. "Elemental analysis: an important purity control but prone to manipulations." Inorganic Chemistry Frontiers, DOI:10.1039/D1QI01379C. Available at: 6.[4] Thermo Fisher Scientific. "Organic Elemental Analysis - Flash 2000 Operating Manual." CAS.cn. Available at:

Need Custom Synthesis?

BenchChem offers custom synthesis for rare earth carbides and specific isotopic labeling.

Email: info@benchchem.com or [Request Quote Online](#).

Sources

- [1. documents.thermofisher.com](https://documents.thermofisher.com) [documents.thermofisher.com]
- [2. Elemental analysis: an important purity control but prone to manipulations - Inorganic Chemistry Frontiers \(RSC Publishing\) DOI:10.1039/D1QI01379C](#) [pubs.rsc.org]
- [3. justagriculture.in](https://justagriculture.in) [justagriculture.in]
- [4. pcce.genetics.cas.cn](https://pcce.genetics.cas.cn) [pcce.genetics.cas.cn]

- [5. scribd.com \[scribd.com\]](#)
- [6. documents.thermofisher.com \[documents.thermofisher.com\]](#)
- To cite this document: BenchChem. [The Causality of Matrix Mismatch: Comparing Analytical Standards]. BenchChem, [2026]. [Online PDF]. Available at: [\[https://www.benchchem.com/product/b11900447/docs#the-causality-of-matrix-mismatch-comparing-analytical-standards\]](https://www.benchchem.com/product/b11900447/docs#the-causality-of-matrix-mismatch-comparing-analytical-standards)

Disclaimer & Data Validity:

The information provided in this document is for Research Use Only (RUO) and is strictly not intended for diagnostic or therapeutic procedures. While BenchChem strives to provide accurate protocols, we make no warranties, express or implied, regarding the fitness of this product for every specific experimental setup.

Technical Support: The protocols provided are for reference purposes. Unsure if this reagent suits your experiment?

Need Industrial/Bulk Grade? [Request Custom Synthesis Quote](#)

BenchChem

Our mission is to be the trusted global source of essential and advanced chemicals, empowering scientists and researchers to drive progress in science and industry.

Contact

Address: 3281 E Guasti Rd
Ontario, CA 91761, United States
Phone: (601) 213-4426
Email: info@benchchem.com

[Contact our Ph.D. Support Team for a compatibility check](#)