

Advanced Structural Elucidation: Mass Spectrometry of Chlorofluoropyridine Esters

Author: BenchChem Technical Support Team. **Date:** April 2026

Compound of Interest

Compound Name: Methyl 2-(6-chloro-2-fluoropyridin-3-yl)acetate

Cat. No.: B11897790

[Get Quote](#)

Executive Summary

Chlorofluoropyridine esters represent a critical scaffold in the development of next-generation agrochemicals (e.g., synthetic auxins like Fluroxypyr) and fluorinated pharmaceuticals. Their structural complexity—arising from multiple halogen substitutions (Cl/F) and ester functionalities—presents unique challenges in structural elucidation.

This guide provides a comparative technical analysis of the mass spectrometric (MS) behavior of these compounds. Unlike standard organic esters, the electron-deficient pyridine core and the "Ortho Effect" exerted by flanking halogens dictate non-intuitive fragmentation pathways. We compare the utility of Electron Ionization (EI) versus Electrospray Ionization (ESI-MS/MS) and provide a framework for differentiating positional isomers.

Mechanism of Fragmentation

To interpret the spectra of chlorofluoropyridine esters, one must understand the competition between the ester functionality and the halogenated pyridine ring.

The "Ortho Effect" and Halogen Interaction

In highly substituted pyridines, the substituents at the C-3 and C-5 positions (ortho to the C-4 ester) sterically and electronically influence fragmentation.[1]

- Fluorine (Ortho): Due to the high C-F bond strength (~485 kJ/mol), fluorine atoms rarely cleave primarily. However, they induce strong inductive effects that destabilize the molecular ion, promoting ester cleavage.
- Chlorine (Ortho): The weaker C-Cl bond (~327 kJ/mol) allows for radical chlorine loss (), often competing with ester fragmentation.[1]

Primary Fragmentation Pathways

- McLafferty Rearrangement: If the ester alkyl chain is C3, a classic six-membered transition state yields the carboxylic acid radical cation and an alkene.
- -Cleavage: Loss of the alkoxy group () to form the acylium ion ().
- Decarboxylation: Subsequent loss of neutral CO from the acylium ion generates the halogenated pyridyl cation.

Comparative Analysis: Methodological Approaches

This section compares the two dominant MS modalities for analyzing these compounds.

Comparison 1: EI (Hard Ionization) vs. ESI (Soft Ionization)[1]

Feature	Electron Ionization (EI) - 70 eV	ESI-MS/MS (Collision Induced Dissociation)
Primary Utility	Structural fingerprinting & library matching.[1]	Quantitation & trace analysis in biological matrices.
Molecular Ion ()	Weak or absent (due to rapid ester cleavage).	Strong or .
Fragmentation Richness	High. Shows complete backbone degradation (Ring opening, HCN loss).	Tunable. Requires optimized Collision Energy (CE) to see ring fragments.
Halogen Pattern	Clear isotopic clusters () visible in all fragments.	Isotopic patterns preserved but often obscured by adducts.
Best For...	Identification of unknown impurities or synthesis byproducts.	PK/PD studies and residue analysis.

Comparison 2: Isomeric Differentiation (The "Product" Performance)

Distinguishing positional isomers (e.g., 3,5-dichloro vs. 2,3-dichloro) is the gold standard of MS performance.[1]

- Symmetric Isomers (e.g., 3,5-dichloro-2,6-difluoro):
 - Produce simple, symmetric fragmentation trees.
 - The peak is often less intense because the symmetry stabilizes the parent structure relative to asymmetric variants.
- Asymmetric Isomers (e.g., 2,3-dichloro-5,6-difluoro):

- Exhibit "crowding" effects. A chlorine atom adjacent to the ring nitrogen (C-2/C-6) is more labile due to lone-pair repulsion.[1]
- Diagnostic Ratio: The ratio of
to
is typically higher in asymmetric isomers.[1]

Visualization of Fragmentation Pathways[2][3][4][5][6]

The following diagram illustrates the fragmentation of a representative compound: Ethyl 3,5-dichloro-2,6-difluoropyridine-4-carboxylate.

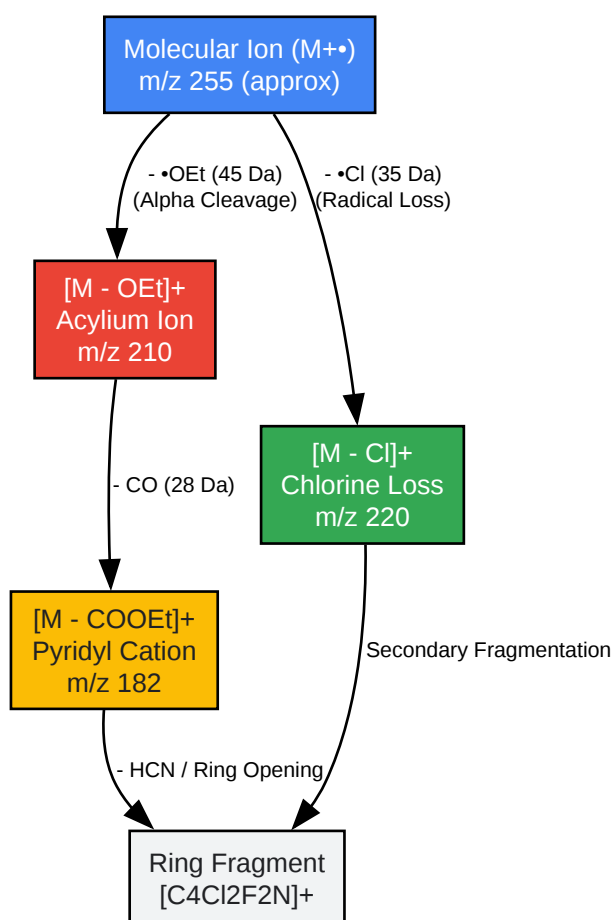

[Click to download full resolution via product page](#)

Caption: Predicted EI fragmentation pathway for Ethyl 3,5-dichloro-2,6-difluoropyridine-4-carboxylate, showing competition between ester cleavage and halogen loss.

Experimental Protocol: Structural Elucidation Workflow

This self-validating protocol ensures reproducible spectral data for chlorofluoropyridine esters. [\[1\]](#)

Phase 1: Sample Preparation[\[1\]](#)

- Solvent Selection: Dissolve 1 mg of sample in Methanol (LC-MS grade). Avoid acetonitrile if using negative mode ESI as it can suppress ionization for halogenated species.
- Concentration: Dilute to 10 µg/mL for direct infusion (ESI) or 100 µg/mL for GC-MS injection.

Phase 2: GC-MS Acquisition (EI Mode)[\[1\]](#)

- Column: Rxi-5Sil MS or equivalent (low bleed is critical for trace halogen analysis).[\[1\]](#)
- Inlet Temp: 250°C.
- Source Temp: 230°C.
- Scan Range: m/z 50–500.
- Validation Step: Check the isotopic pattern of the molecular ion.[\[2\]](#) For a dichloro- species, the M, M+2, and M+4 peaks must appear in a 9:6:1 intensity ratio. If this ratio deviates >10%, check for co-eluting impurities or detector saturation.

Phase 3: LC-MS/MS Acquisition (ESI Mode)[\[1\]](#)

- Mobile Phase: A: Water + 0.1% Formic Acid; B: Methanol + 0.1% Formic Acid.
- Gradient: 50% B to 95% B over 5 minutes. (Halogenated esters are hydrophobic).
- MS/MS Settings:

- Precursor Isolation Width: 1.0 Da.
- Collision Energy (CE): Stepped CE (15, 30, 45 eV) is mandatory to capture both the intact ester loss and the hard ring fragmentation.

Data Summary: Diagnostic Ions

The table below summarizes the theoretical diagnostic ions for Ethyl 3,5-dichloro-2,6-difluoropyridine-4-carboxylate (MW ≈ 255, based on

).

Fragment Ion	m/z (Nominal)	Origin	Relative Abundance (EI)
Molecular Ion	255		Low (<10%)
Acylium Ion	210		High (Base Peak candidate)
Pyridyl Cation	182		Medium
Chlorine Loss	220		Low-Medium
Ring Fragment	147		Low

Note: m/z values will shift by +2 Da for

isotopes.[\[1\]](#)

References

- NIST Mass Spectrometry Data Center. (2025).[\[3\]](#) Fluroxypyr Mass Spectrum (Electron Ionization).[\[4\]](#) National Institute of Standards and Technology.[\[5\]](#) [\[Link\]](#)[\[1\]](#)
- McLafferty, F. W., & Tureček, F. (1993). Interpretation of Mass Spectra (4th ed.). University Science Books. (Standard reference for McLafferty rearrangement mechanisms).
- U.S. National Library of Medicine. (2025). PubChem Compound Summary for CID 50465, Fluroxypyr.[\[Link\]](#)[\[1\]](#)

Need Custom Synthesis?

BenchChem offers custom synthesis for rare earth carbides and specific isotopic labeling.

Email: info@benchchem.com or [Request Quote Online](#).

Sources

- [1. Fluroxypyr \[webbook.nist.gov\]](#)
- [2. researchgate.net \[researchgate.net\]](#)
- [3. Fluroxypyr | C7H5Cl2FN2O3 | CID 50465 - PubChem \[pubchem.ncbi.nlm.nih.gov\]](#)
- [4. Fluroxypyr \[webbook.nist.gov\]](#)
- [5. 2,6-Difluoropyridine \[webbook.nist.gov\]](#)
- To cite this document: BenchChem. [Advanced Structural Elucidation: Mass Spectrometry of Chlorofluoropyridine Esters]. BenchChem, [2026]. [Online PDF]. Available at: [\[https://www.benchchem.com/product/b11897790/docs#advanced-structural-elucidation-mass-spectrometry-of-chlorofluoropyridine-esters\]](https://www.benchchem.com/product/b11897790/docs#advanced-structural-elucidation-mass-spectrometry-of-chlorofluoropyridine-esters)

Disclaimer & Data Validity:

The information provided in this document is for Research Use Only (RUO) and is strictly not intended for diagnostic or therapeutic procedures. While BenchChem strives to provide accurate protocols, we make no warranties, express or implied, regarding the fitness of this product for every specific experimental setup.

Technical Support: The protocols provided are for reference purposes. Unsure if this reagent suits your experiment?

Need Industrial/Bulk Grade? [Request Custom Synthesis Quote](#)

BenchChem

Our mission is to be the trusted global source of essential and advanced chemicals, empowering scientists and researchers to drive progress in science and industry.

Contact

Address: 3281 E Guasti Rd

Ontario, CA 91761, United States

Phone: (601) 213-4426

Email: info@benchchem.com

[Contact our Ph.D. Support Team for a compatibility check](#)