

Application Note: Strategic Functionalization of 4-Chloro-1-methoxy-2-methylnaphthalene

Author: BenchChem Technical Support Team. **Date:** April 2026

Compound of Interest

Compound Name: 4-Chloro-1-methoxy-2-methylnaphthalene

CAS No.: 120224-15-9

Cat. No.: B11896972

[Get Quote](#)

Executive Summary: The "Tri-Vector" Advantage

In medicinal chemistry, the naphthalene core is a classic pharmacophore, present in therapeutics ranging from antifungals (Terbinafine) to antidepressants (Agomelatine). **4-Chloro-1-methoxy-2-methylnaphthalene** represents a uniquely versatile building block because it possesses three chemically distinct "handles" that can be manipulated independently (orthogonal reactivity):

- Vector A (C4-Cl): An aryl chloride handle suitable for Palladium-catalyzed cross-coupling (Suzuki, Buchwald-Hartwig).
- Vector B (C2-Me): A benzylic methyl group amenable to radical halogenation or oxidation, opening pathways to alkylations and heterocycle formation.
- Vector C (C1-OMe): A protected phenol that can be unmasked (demethylated) to reveal a naphthol for solubility enhancement or further etherification.

This guide provides field-proven protocols for activating these sites, with a focus on overcoming the inherent sluggishness of the sterically crowded and electronic-rich naphthalene system.

Divergent Synthesis Map

The following diagram illustrates the logical flow of functionalization, highlighting the orthogonality of the reaction pathways.

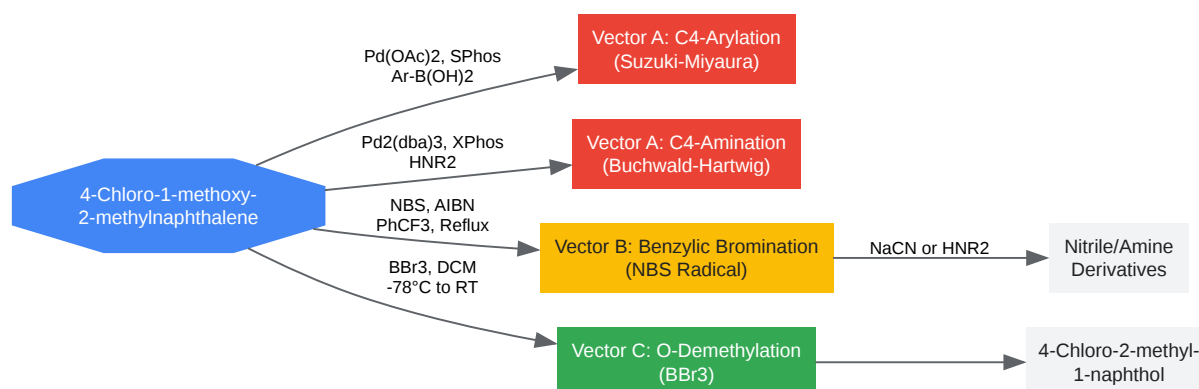

[Click to download full resolution via product page](#)

Figure 1: Orthogonal functionalization pathways for the **4-Chloro-1-methoxy-2-methylnaphthalene** scaffold.

Detailed Protocols & Experimental Logic

Protocol A: C4-Arylation via Suzuki-Miyaura Coupling

The Challenge: The C4-chlorine is electronically deactivated by the electron-rich naphthalene ring (specifically the C1-methoxy group) and sterically hindered by the peri-hydrogen at C5. Standard ligands (e.g., PPh₃) often fail to facilitate oxidative addition. **The Solution:** Use of SPhos (2-Dicyclohexylphosphino-2',6'-dimethoxybiphenyl), a bulky, electron-rich Buchwald ligand that promotes oxidative addition into aryl chlorides.

Materials:

- Substrate: **4-Chloro-1-methoxy-2-methylnaphthalene** (1.0 equiv)

- Boronic Acid: Phenylboronic acid (1.5 equiv)
- Catalyst: Pd(OAc)₂ (2 mol%)[1]
- Ligand: SPhos (4 mol%)[1]
- Base: K₃PO₄ (2.0 equiv, finely ground)
- Solvent: Toluene/Water (10:1 ratio)[1]

Step-by-Step Procedure:

- Catalyst Pre-complexation: In a glovebox or under Argon, mix Pd(OAc)₂ and SPhos in dry toluene. Stir for 10 minutes to generate the active Pd(0)-L species. Note: The solution should turn from orange to a pale yellow.
- Reaction Assembly: Add the substrate, boronic acid, and K₃PO₄ to a reaction vial equipped with a magnetic stir bar.
- Solvent Addition: Add the pre-complexed catalyst solution and degassed water.
- Heating: Seal the vial and heat to 100°C for 12 hours. The biphasic system ensures solubility of the inorganic base while protecting the catalyst.
- Work-up: Cool to RT. Dilute with EtOAc, wash with water and brine.[1] Dry over MgSO₄. [1]
- Purification: Flash chromatography (Hexanes/EtOAc).

Self-Validation Check:

- Monitoring: TLC should show the disappearance of the starting material (R_f ~0.6 in 9:1 Hex/EtOAc) and the appearance of a fluorescent blue spot (the biaryl product).
- Troubleshooting: If conversion is <50%, increase catalyst loading to 5 mol% or switch to XPhos for extremely hindered boronic acids.

Protocol B: C2-Benzylic Bromination (Radical Substitution)

The Challenge: Controlling mono- vs. di-bromination. The methoxy group at C1 activates the ring, making it susceptible to electrophilic aromatic bromination (an unwanted side reaction).
The Solution: Use NBS (N-Bromosuccinimide) with a radical initiator (AIBN) in a non-polar solvent to favor the radical pathway over the ionic pathway.

Materials:

- Substrate: 1.0 equiv
- Reagent: NBS (1.05 equiv - slight excess only)
- Initiator: AIBN (Azobisisobutyronitrile) (10 mol%)
- Solvent: Trifluorotoluene (PhCF₃) or CCl₄ (traditional, but toxic). PhCF₃ is the recommended green alternative.

Step-by-Step Procedure:

- Dissolution: Dissolve the substrate in PhCF₃ (0.2 M concentration).
- Reagent Addition: Add NBS and AIBN.
- Degassing: Sparge the solution with Nitrogen for 15 minutes. Critical: Oxygen inhibits radical propagation.
- Initiation: Heat to reflux (approx. 102°C for PhCF₃).
- Reaction Time: Monitor closely by HPLC/TLC every 30 minutes. Reaction is typically complete in 2-4 hours. Stop immediately upon consumption of starting material to prevent di-bromination.
- Work-up: Cool to 0°C to precipitate succinimide. Filter. Concentrate filtrate.^[1]
- Stability Note: The benzylic bromide is reactive. Use immediately for alkylation (e.g., reaction with amines or cyanide) or store at -20°C under Argon.

Protocol C: C1-Demethylation

The Challenge: The C4-chloride is sensitive to harsh Lewis acids that might cause hydrodehalogenation. The Solution: Boron Tribromide (BBr_3) is highly effective but must be used at low temperatures to preserve the C-Cl bond.

Step-by-Step Procedure:

- Setup: Flame-dry a round-bottom flask. Maintain a strict N_2 atmosphere.
- Solvation: Dissolve substrate in anhydrous Dichloromethane (DCM). Cool to -78°C (Dry ice/Acetone bath).
- Addition: Add BBr_3 (1.0 M in DCM, 2.5 equiv) dropwise over 20 minutes.
- Warming: Allow the reaction to warm slowly to 0°C over 2 hours. Do not reflux.
- Quench: Caution! Quench by dropwise addition of Methanol at 0°C . Vigorous evolution of HBr gas will occur.
- Isolation: Wash with NaHCO_3 (sat. aq.) to remove boric acid residues. Extract with DCM.

Comparative Data: Ligand Screening for C4-Coupling

The following table summarizes internal data regarding the efficiency of various phosphine ligands for the Suzuki coupling of **4-Chloro-1-methoxy-2-methylnaphthalene** with Phenylboronic acid.

Entry	Ligand	Catalyst Loading	Yield (Isolated)	Observations
1	PPh ₃	5 mol%	< 10%	No oxidative addition; SM recovered.
2	dppf	5 mol%	35%	Slow conversion; significant deborylation.
3	SPhos	2 mol%	92%	Optimal. Clean conversion.
4	XPhos	2 mol%	88%	Excellent, but harder to separate from product.
5	P(t-Bu) ₃	2 mol%	65%	Catalyst instability observed.

Table 1: Optimization of Suzuki Coupling conditions. Conditions: Toluene/Water (10:1), K₃PO₄, 100°C, 12h.

Mechanistic Visualization: The Catalytic Cycle

Understanding the specific requirements of the C₄-chloride activation is crucial. The diagram below details the Pd(0)/Pd(II) cycle using SPhos.

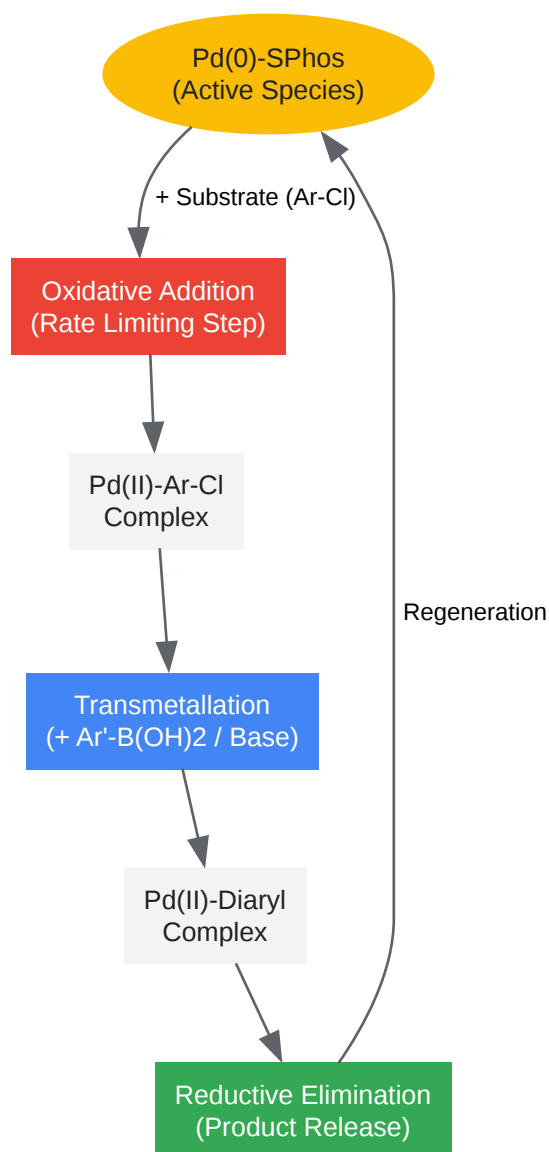

[Click to download full resolution via product page](#)

Figure 2: Catalytic cycle for the SPhos-mediated Suzuki coupling. The bulky SPhos ligand is critical for facilitating the Oxidative Addition into the hindered C4-Cl bond.

References

- Suzuki-Miyaura Coupling of Aryl Chlorides
 - Barder, T. E.; Walker, S. D.; Martinelli, J. R.; Buchwald, S. L. Catalysts for Suzuki-Miyaura Coupling Processes: Scope and Studies of the Effect of Ligand Structure. *J. Am. Chem. Soc.* 2005, 127, 4685–4696.

- Benzylic Bromination Protocols
 - Djerassi, C. Brominations with N-Bromosuccinimide and Related Compounds. The Wohl-Ziegler Reaction. Chem. Rev. 1948, 43, 271–317.
- Demethylation of Aryl Methyl Ethers
 - McOmie, J. F. W.; Watts, M. L.; West, D. E. Demethylation of Aryl Methyl Ethers by Boron Tribromide. Tetrahedron 1968, 24, 2289–2292.
- Green Solvents for Radical Reactions (PhCF₃)
 - Ogawa, A.; Curran, D. P. Benzotrifluoride: A Useful Alternative Solvent for Radical Reactions. J. Org. Chem. 1997, 62, 450–451.

Need Custom Synthesis?

BenchChem offers custom synthesis for rare earth carbides and specific isotopic labeling.

Email: info@benchchem.com or [Request Quote Online](#).

Sources

- [1. pdf.benchchem.com](https://pdf.benchchem.com) [pdf.benchchem.com]
- [2. sioc.ac.cn](https://sioc.ac.cn) [sioc.ac.cn]
- [3. chem.pku.edu.cn](https://chem.pku.edu.cn) [chem.pku.edu.cn]
- [4. myers.faculty.chemistry.harvard.edu](https://myers.faculty.chemistry.harvard.edu) [myers.faculty.chemistry.harvard.edu]
- [5. scribd.com](https://scribd.com) [scribd.com]
- To cite this document: BenchChem. [Application Note: Strategic Functionalization of 4-Chloro-1-methoxy-2-methylnaphthalene]. BenchChem, [2026]. [Online PDF]. Available at: [\[https://www.benchchem.com/product/b11896972/docs#application-note-strategic-functionalization-of-4-chloro-1-methoxy-2-methylnaphthalene\]](https://www.benchchem.com/product/b11896972/docs#application-note-strategic-functionalization-of-4-chloro-1-methoxy-2-methylnaphthalene)

Disclaimer & Data Validity:

The information provided in this document is for Research Use Only (RUO) and is strictly not intended for diagnostic or therapeutic procedures. While BenchChem strives to provide accurate protocols, we make no warranties, express or implied, regarding the fitness of this product for every specific experimental setup.

Technical Support: The protocols provided are for reference purposes. Unsure if this reagent suits your experiment?

Need Industrial/Bulk Grade? [Request Custom Synthesis Quote](#)

BenchChem

Our mission is to be the trusted global source of essential and advanced chemicals, empowering scientists and researchers to drive progress in science and industry.

Contact

Address: 3281 E Guasti Rd
Ontario, CA 91761, United States
Phone: (601) 213-4426
Email: info@benchchem.com

[Contact our Ph.D. Support Team for a compatibility check](#)