

Mass Spectrometry Fragmentation Patterns: Indazole Dicarboxylic Acids[1]

Author: BenchChem Technical Support Team. **Date:** April 2026

Compound of Interest

Compound Name: *1H-Indazole-3,7-dicarboxylic acid*

Cat. No.: *B11894627*

[Get Quote](#)

Executive Summary

Indazole dicarboxylic acids (e.g., 1H-indazole-3,5-dicarboxylic acid) are critical scaffolds in the development of Akt kinase inhibitors and synthetic cannabinoids. Their structural analysis is often complicated by the presence of isomeric alternatives, such as indole dicarboxylic acids.

This guide defines the "performance" of MS analysis as the ability to:

- Unambiguously distinguish the indazole core (2 nitrogens) from the indole core (1 nitrogen).
- Map substituent positions (e.g., 3,5- vs. 3,6-substitution) via characteristic neutral losses.

Comparative Analysis: Indazole vs. Indole Scaffolds

The primary differentiator in Mass Spectrometry between these two scaffolds is the Nitrogen Rule and the stability of the N-N bond in the indazole ring.

Feature	Indazole Dicarboxylic Acid	Indole Dicarboxylic Acid	MS/MS Differentiator
Core Structure	1,2-Diazole (Benzopyrazole)	Benzopyrrole	Nitrogen Count
Molecular Weight	Even (e.g., C H N O = 206 Da)	Odd (e.g., C H NO = 205 Da)	Nitrogen Rule Validity
Primary Ionization	(Odd mass)	(Even mass)	Precursor Ion Mass Parity
Base Peak (Core)	145 (Acylium-Indazole)	144 (Acylium-Indole)	Core Fragment Mass Shift
Ring Stability	High (N-N bond resists cleavage)	Moderate (C2-C3 cleavage possible)	Retro-Diels-Alder (RDA) prevalence

Fragmentation Mechanisms

A. The Indazole Pathway (The "Stable Core" Mechanism)

Indazole dicarboxylic acids typically undergo sequential neutral losses of water and carbon dioxide before the core ring system fragments. The N-N bond provides significant stability, often preserving the heterocyclic ring until high collision energies are applied.

- Step 1: Dehydration (

-18): The carboxylic acid groups interact, often via an "ortho effect" if adjacent to a ring nitrogen or another substituent, leading to the loss of H

O.

- Step 2: Decarboxylation (

-44): Loss of CO

is the dominant pathway for dicarboxylic acids. In 3-carboxyindazoles, the C3-COOH is labile.

- Step 3: Core Activation (

145): The formation of the acylium ion (

) at

145 is a diagnostic fingerprint for indazole-3-carboxylic acid derivatives.

B. The Indole Pathway (The "Indolic Switch")

Indole analogs follow a similar dehydration/decarboxylation path but result in a mass shift of -1 Da (or +1 Da depending on substitution) in the core fragments due to the single nitrogen atom. The characteristic acylium ion appears at

144.[1]

Visualization: Fragmentation Pathways

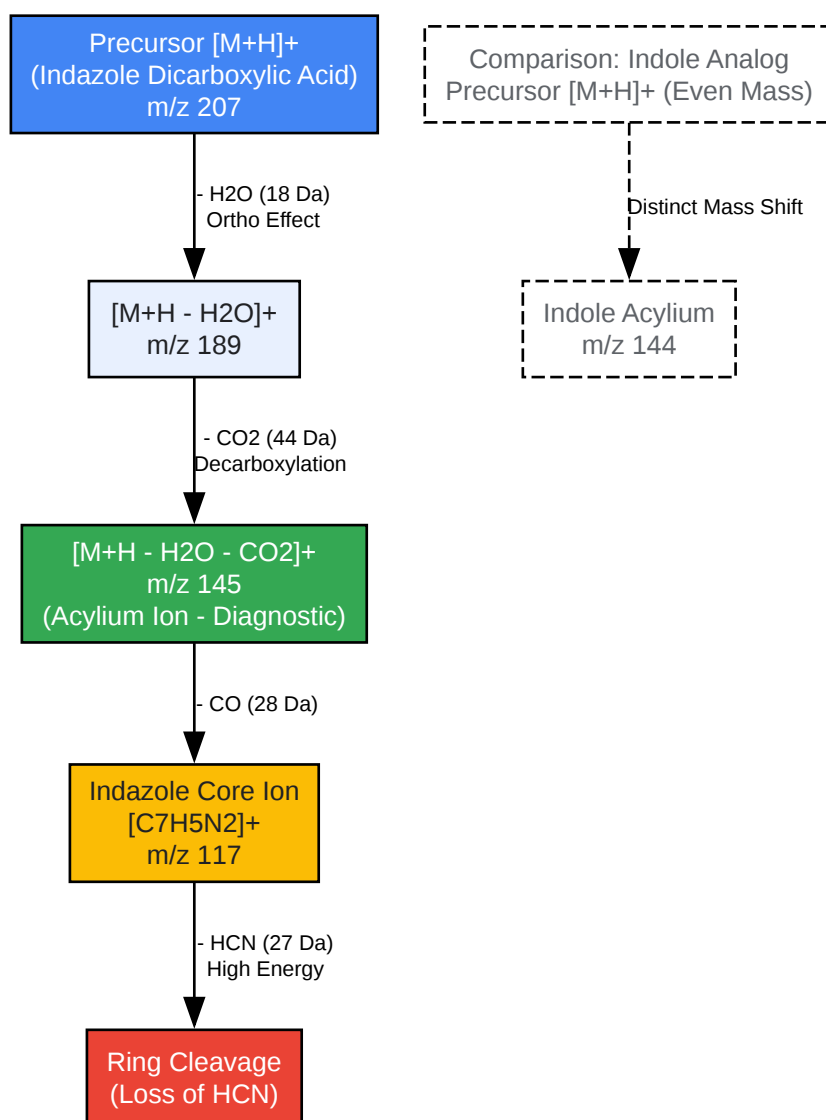

[Click to download full resolution via product page](#)

Caption: Comparative fragmentation pathway of Indazole Dicarboxylic Acid showing the diagnostic m/z 145 acylium ion.

Experimental Protocol

To replicate these fragmentation patterns for structural validation, use the following standardized LC-MS/MS protocol. This workflow maximizes the ionization of the carboxylic acid moieties while promoting informative fragmentation.

Phase 1: Sample Preparation

- Solvent: Dissolve 1 mg of analyte in Methanol:Water (50:50).

- Additive: Add 0.1% Formic Acid. Rationale: Acidic pH ensures protonation of the basic indazole nitrogens () and the carboxylic acids for ESI+ mode.
- Concentration: Dilute to 1 µg/mL for direct infusion or LC injection.

Phase 2: LC-MS/MS Parameters (ESI+)

- Ionization Source: Electrospray Ionization (ESI) – Positive Mode.
- Capillary Voltage: 3.5 kV.
- Cone Voltage: 30 V (Low voltage prevents in-source decarboxylation).
- Collision Energy (CE): Stepped Ramp (10, 20, 40 eV).
 - 10 eV: Retains .
 - 20 eV: Exposes neutral losses (H O, CO).
 - 40 eV: Fragments the aromatic core (RDA cleavage).

Phase 3: Data Interpretation Workflow

- Check Nitrogen Rule: Does the parent ion mass suggest an even (2N) or odd (1N) nitrogen count?
- Identify Neutral Losses: Look for (Water) and (CO).

- Locate Diagnostic Ion:
 - 145: Confirms Indazole-3-carboxyl core.
 - 144: Confirms Indole-3-carboxyl core.

Diagnostic Ion Table

Fragment Ion	(Approx)	Origin	Structural Significance
	207.04	Molecular Ion	Confirm MW & Nitrogen Rule (Odd mass = Even N).
	189.03	Carboxyl Group	Indicates at least one COOH or OH; common in dicarboxylic acids.
	145.04	Acylium Ion	Primary Diagnostic: Indazole ring + Carbonyl. Distinguishes from Indole.
	117.04	Indazole Core	Protonated indazole ring after full side-chain loss.
	90.03	Ring Fragment	Loss of HCN from the core (High Energy).

References

- Shevyrin, V., et al. (2013). Analytical characterization of some synthetic cannabinoids, derivatives of indole-3-carboxylic acid. Forensic Science International. Retrieved from [\[Link\]](#)
- Kusano, M., et al. (2019). Fragmentation of Dicarboxylic and Tricarboxylic Acids in the Krebs Cycle Using GC-EI-MS. Mass Spectrometry (Tokyo). Retrieved from [\[Link\]](#)

- PubChem. (2025).[2][3] 1H-Indazole-3-carboxylic acid Data Sheet. National Library of Medicine. Retrieved from [[Link](#)]
- Longdom Publishing. (2020). Charge reversal derivatization enhances dicarboxylic acid quantification using liquid chromatography tandem mass spectrometry. Retrieved from [[Link](#)]
[4][5]

Need Custom Synthesis?

BenchChem offers custom synthesis for rare earth carbides and specific isotopic labeling.

Email: info@benchchem.com or [Request Quote Online](#).

Sources

- [1. researchgate.net \[researchgate.net\]](https://www.researchgate.net)
- [2. 1H-Imidazole-4,5-dicarboxylic acid | C₅H₄N₂O₄ | CID 68442 - PubChem \[pubchem.ncbi.nlm.nih.gov\]](https://pubchem.ncbi.nlm.nih.gov/compound/1H-Imidazole-4,5-dicarboxylic-acid)
- [3. Indazole-3-carboxylic acid | C₈H₆N₂O₂ | CID 78250 - PubChem \[pubchem.ncbi.nlm.nih.gov\]](https://pubchem.ncbi.nlm.nih.gov/compound/Indazole-3-carboxylic-acid)
- [4. derpharmachemica.com \[derpharmachemica.com\]](https://www.derpharmachemica.com)
- [5. diva-portal.org \[diva-portal.org\]](https://www.diva-portal.org)
- To cite this document: BenchChem. [Mass Spectrometry Fragmentation Patterns: Indazole Dicarboxylic Acids[1]]. BenchChem, [2026]. [Online PDF]. Available at: [<https://www.benchchem.com/product/b11894627/docs#mass-spectrometry-fragmentation-patterns-indazole-dicarboxylic-acids-1>]

Disclaimer & Data Validity:

The information provided in this document is for Research Use Only (RUO) and is strictly not intended for diagnostic or therapeutic procedures. While BenchChem strives to provide accurate protocols, we make no warranties, express or implied, regarding the fitness of this product for every specific experimental setup.

Technical Support: The protocols provided are for reference purposes. Unsure if this reagent suits your experiment?

Need Industrial/Bulk Grade? [Request Custom Synthesis Quote](#)

BenchChem

Our mission is to be the trusted global source of essential and advanced chemicals, empowering scientists and researchers to drive progress in science and industry.

Contact

Address: 3281 E Guasti Rd
Ontario, CA 91761, United States
Phone: (601) 213-4426
Email: info@benchchem.com

[Contact our Ph.D. Support Team for a compatibility check](#)