

Technical Support Center: Stability of 5-Chloro-3-hydroxybenzofuran-2-carboxamide

Author: BenchChem Technical Support Team. **Date:** April 2026

Compound of Interest

Compound Name: 5-Chloro-3-hydroxybenzofuran-2-carboxamide

Cat. No.: B11892310

[Get Quote](#)

Executive Summary: The Chemical "Personality"

5-Chloro-3-hydroxybenzofuran-2-carboxamide is not a static molecule; it is a dynamic tautomeric system highly sensitive to the pH environment. While the 5-chloro substitution provides some metabolic stability compared to the unsubstituted parent, the core scaffold possesses three critical reactivity "hotspots" under basic conditions:

- **Acidity of the 3-OH group:** The electron-withdrawing nature of the 2-carboxamide and 5-chloro groups significantly increases the acidity of the 3-hydroxyl group (Predicted pKa 6.5–7.5). In basic media, it exists almost exclusively as the enolate anion.
- **Oxidative Instability:** The deprotonated enolate is electron-rich and highly susceptible to oxidative dimerization or quinone formation if oxygen is present.
- **Amide Hydrolysis & Ring Opening:** Strong bases (pH > 10) or elevated temperatures trigger irreversible hydrolysis of the amide to the carboxylic acid, and in extreme cases, can force the opening of the furan ring via a "coumaran-3-one" intermediate.

Mechanistic Stability Profile

To troubleshoot effectively, you must understand the degradation pathways. The diagram below illustrates the fate of the molecule when exposed to base (

).

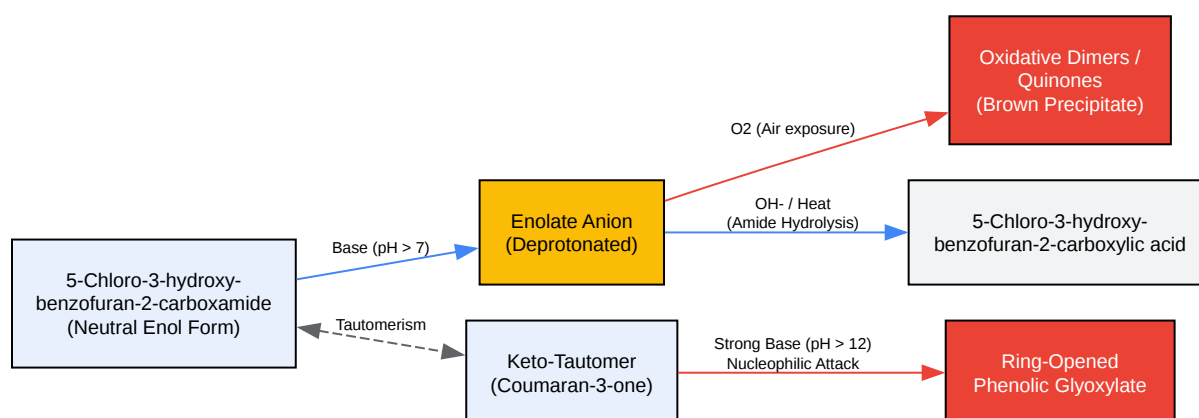

[Click to download full resolution via product page](#)

Figure 1: Degradation network showing the critical pivot point at the Enolate Anion. Note that oxidative degradation is often faster than hydrolysis if oxygen is not excluded.

Troubleshooting Guide (FAQ)

Issue 1: "My solution turned yellow/brown within minutes of adding base."

- **Diagnosis:** Oxidative Degradation. The 3-hydroxybenzofuran enolate is a potent reducing agent. In the presence of dissolved oxygen, it undergoes radical coupling to form colored dimers or quinones. This is similar to the "browning" of apple slices (polyphenol oxidation).
- **Corrective Action:**
 - **Degas Solvents:** Sparge all buffers with Argon or Nitrogen for 15 minutes before dissolving the compound.

- Add Antioxidants: If compatible with your assay, add 1-5 mM Ascorbic Acid or DTT to the buffer.
- Work under Inert Atmosphere: Perform base additions in a glovebox or under a nitrogen blanket.

Issue 2: "I see peak splitting or broad humps in my HPLC chromatogram."

- Diagnosis: Keto-Enol Tautomerism. In neutral or slightly basic HPLC mobile phases, the compound interconverts between the 3-hydroxy (enol) and coumaran-3-one (keto) forms on the timescale of the separation.
- Corrective Action:
 - Acidify Mobile Phase: Ensure your mobile phase contains 0.1% Formic Acid or TFA (pH < 3). This locks the compound in the stable, neutral enol form via intramolecular hydrogen bonding with the amide.
 - Temperature Control: Lower the column temperature (e.g., to 10°C) to slow the tautomerization rate, sharpening the peaks.

Issue 3: "The parent mass (M+) is disappearing, and I see a new peak at M+1."

- Diagnosis: Amide Hydrolysis. The mass shift of +1 Da (actually +0.984 Da:) indicates the conversion of the Carboxamide to the Carboxylic Acid.
- Corrective Action:
 - Lower pH: Avoid pH > 9.0. The hydrolysis rate is second-order with respect to .
 - Switch Buffers: Replace strong nucleophilic bases (like hydroxide) with non-nucleophilic buffers (e.g., Carbonate or Phosphate) if high pH is absolutely required.

- Cold Storage: Never store basic stock solutions. Prepare fresh or freeze at -80°C immediately.

Experimental Protocols

Protocol A: Base Stability Stress Test

Use this protocol to determine the "Safe Time Window" for your specific experiments.

Materials:

- Compound Stock (10 mM in DMSO)
- Buffer A: 50 mM Phosphate Buffer, pH 7.4
- Buffer B: 50 mM Borate Buffer, pH 10.0
- Quench Solution: 10% Formic Acid in Acetonitrile

Workflow:

- Preparation: Dilute Compound Stock to $50\ \mu\text{M}$ in Buffer A and Buffer B in separate amber glass vials (to prevent photodegradation).
- Incubation: Incubate at 25°C .
- Sampling: At

, remove $100\ \mu\text{L}$ of the mixture.
- Quench: Immediately add $100\ \mu\text{L}$ of Quench Solution. (This stops hydrolysis and locks tautomers).
- Analysis: Analyze via HPLC-UV/MS.
 - Success Criteria: $>95\%$ recovery of parent peak.
 - Failure: Appearance of Hydrolysis product (Acid derivative) or loss of mass balance (Oxidation/Polymerization).

Protocol B: Tautomer Identification (NMR)

Use this if you suspect the Keto form is interfering with binding assays.

- Dissolve 5 mg of compound in

.
- Acquire a standard

-NMR.
- Diagnostic Signals:
 - Enol Form: Sharp singlet at

10.0–12.0 ppm (OH, often H-bonded to amide).
 - Keto Form: Look for a singlet at

~5.5–6.0 ppm (the

proton of the coumaran-3-one ring).
- Add 1 drop of

with

(Base). Observe the disappearance of the OH/NH peaks and potential shift in aromatic protons due to increased electron density (Enolate formation).

Summary Data Table: Stability Limits

Parameter	Condition	Stability Status	Primary Risk
Acidic (pH < 4)	Stable	High	Protonation of amide (reversible).
Neutral (pH 7)	Stable	High	Slow oxidation if exposed to light/air over days.
Mild Base (pH 8-9)	Metastable	Moderate	Oxidation (hours in air).
Strong Base (pH > 10)	Unstable	Low	Amide Hydrolysis (hour).
Nucleophiles	Reactive	Very Low	Ring opening (if nucleophile attacks C2).

References

- Tautomerism in 3-Hydroxybenzofurans
 - Mechanism:[\[1\]](#)[\[2\]](#)[\[3\]](#)[\[4\]](#)[\[5\]](#) The equilibrium between 3-hydroxybenzofurans and coumaran-3-ones is pH-dependent. The enol form is generally favored by intramolecular hydrogen bonding with C2-carbonyl substituents (like carboxamides).
 - Source: Benassi, R., et al. "Tautomerism of 3-hydroxybenzofuran derivatives." Journal of the Chemical Society, Perkin Transactions 2, 1993.
- Amide Hydrolysis Kinetics
 - Mechanism:[\[1\]](#)[\[2\]](#)[\[3\]](#)[\[4\]](#)[\[5\]](#) Base-catalyzed hydrolysis of benzofuran-2-carboxamides proceeds via the tetrahedral intermediate. Electron-withdrawing groups (like 5-Cl) accelerate this process by stabilizing the transition state.
 - Source: Bowden, K., et al. "Hydrolysis of amides. Part V. Dilute acid and base hydrolysis of some substituted benzamides." Journal of the Chemical Society B, 1971.

- Ring Opening (Isobenzofuranone Rearrangement)
 - Mechanism:[1][2][3][4][5] Under highly alkaline conditions, the furan ring oxygen can act as a leaving group if the C2 position is attacked, leading to ring-opened phenolic glyoxylates.
 - Source:Heterocyclic Chemistry, 5th Ed. Joule & Mills. (Chapter: Benzo-fused Five-membered Heterocycles).
- Oxidative Instability of Enolates
 - Context: 3-hydroxybenzofurans are structural analogues to flavonoids/aurones, which are known antioxidants that degrade via oxid
 - Source: "Antioxidant activity of benzofuran derivatives." European Journal of Medicinal Chemistry, 2010.

Need Custom Synthesis?

BenchChem offers custom synthesis for rare earth carbides and specific isotopic labeling.

Email: info@benchchem.com or [Request Quote Online](#).

Sources

- [1. A new method for the synthesis of 3-hydroxymethylbenzofuran \[html.rhhz.net\]](#)
- [2. researchgate.net \[researchgate.net\]](#)
- [3. pubs.acs.org \[pubs.acs.org\]](#)
- [4. researchgate.net \[researchgate.net\]](#)
- [5. Ring–chain tautomerism and protolytic equilibria of 3-hydroxy-3-phosphonoisobenzofuranone studied by 1H, 13C and 31P NMR-controlled titrations - New Journal of Chemistry \(RSC Publishing\) \[pubs.rsc.org\]](#)
- To cite this document: BenchChem. [Technical Support Center: Stability of 5-Chloro-3-hydroxybenzofuran-2-carboxamide]. BenchChem, [2026]. [Online PDF]. Available at: [\[https://www.benchchem.com/product/b11892310/docs#technical-support-center-stability-of-5-chloro-3-hydroxybenzofuran-2-carboxamide\]](https://www.benchchem.com/product/b11892310/docs#technical-support-center-stability-of-5-chloro-3-hydroxybenzofuran-2-carboxamide)

Disclaimer & Data Validity:

The information provided in this document is for Research Use Only (RUO) and is strictly not intended for diagnostic or therapeutic procedures. While BenchChem strives to provide accurate protocols, we make no warranties, express or implied, regarding the fitness of this product for every specific experimental setup.

Technical Support: The protocols provided are for reference purposes. Unsure if this reagent suits your experiment?

Need Industrial/Bulk Grade? [Request Custom Synthesis Quote](#)

BenchChem

Our mission is to be the trusted global source of essential and advanced chemicals, empowering scientists and researchers to drive progress in science and industry.

Contact

Address: 3281 E Guasti Rd
Ontario, CA 91761, United States
Phone: (601) 213-4426
Email: info@benchchem.com

[Contact our Ph.D. Support Team for a compatibility check](#)