

# Lipophilicity Modulation in Pyrimidine Boronic Acids: A Comparative Technical Guide

**Author:** BenchChem Technical Support Team. **Date:** April 2026

## Compound of Interest

Compound Name: (2,4-Diethoxypyrimidin-5-yl)boronic acid

Cat. No.: B11891454

[Get Quote](#)

## Executive Summary

In medicinal chemistry and process development, the choice between 2,4-dimethoxypyrimidine-5-boronic acid and its 2,4-diethoxy analog is rarely arbitrary. While they share a core reactivity profile in Suzuki-Miyaura cross-couplings, their physicochemical divergence—specifically lipophilicity (LogP/LogD)—dictates their behavior in biological membranes, solubility in green solvent systems, and hydrolytic stability.

This guide analyzes the lipophilic shift resulting from methylene homologation (addition) and provides a validated protocol for accurately measuring these values, addressing the unique challenge of the boronic acid-boroxine equilibrium.

## Structural Analysis & Theoretical Lipophilicity

The fundamental difference between the two molecules lies in the alkyl chains attached to the pyrimidine oxygens.

- Molecule A: 2,4-Dimethoxypyrimidine-5-boronic acid (

)

- Molecule B: 2,4-Diethoxypyrimidine-5-boronic acid (

)

## The Methylene Effect

According to the principles established by Hansch and Leo, the addition of a single methylene group (

) to an aliphatic chain typically increases the LogP value by approximately 0.5 units.

- Transition: Dimethoxy

Diethoxy involves the addition of two methylene groups.

- Theoretical Shift (

LogP):

LogP units.

Consequently, the diethoxy analog is significantly more lipophilic. This has two immediate causal effects:

- Solubility: The diethoxy analog exhibits reduced aqueous solubility, often requiring higher percentages of organic co-solvents (e.g., THF, Dioxane) during synthesis.
- Permeability: The increased lipophilicity enhances passive diffusion across lipid bilayers, potentially improving cellular potency for drug candidates derived from this scaffold.

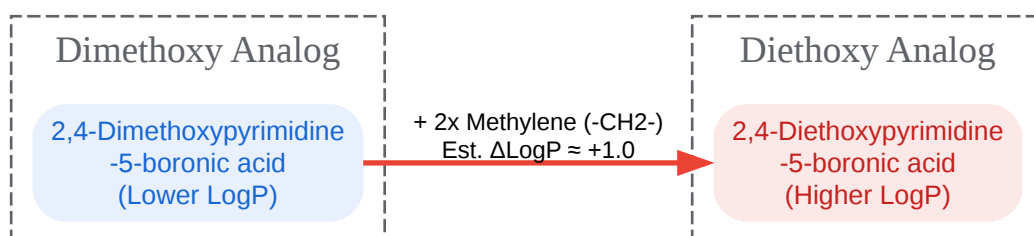

[Click to download full resolution via product page](#)

Figure 1: Structural homologation and predicted lipophilicity shift.

## The Boronic Acid Paradox: Measurement Challenges

Measuring the lipophilicity of boronic acids is not straightforward due to their "chameleon-like" nature. Unlike standard organic molecules, boronic acids exist in a dynamic equilibrium that is solvent- and pH-dependent.

### The Three Species Problem

- Boronic Acid (Monomer): The neutral species, predominant in dilute aqueous solution at neutral pH.
- Boronate Anion: At  $\text{pH} > \text{pKa}$  (~8-9), the boron center accepts a hydroxide ion, becoming negatively charged and highly hydrophilic (LogD drops precipitously).
- Boroxine (Trimer): In non-polar solvents or solid state, three boronic acid molecules dehydrate to form a six-membered boroxine ring. This trimer is much more lipophilic than the monomer.

Critical Insight: Standard "Shake-Flask" (Octanol/Water) methods often fail for boronic acids because the concentration in the octanol phase promotes boroxine formation, artificially inflating the measured LogP.

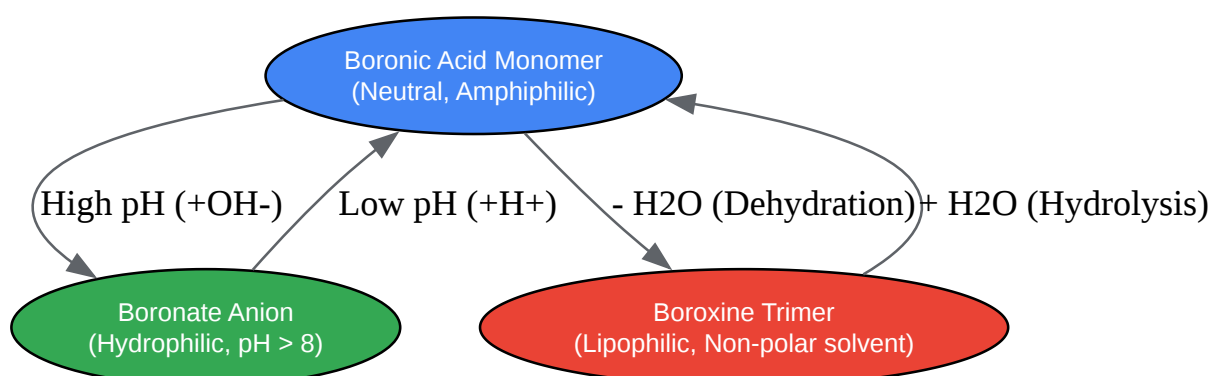

[Click to download full resolution via product page](#)

Figure 2: The dynamic equilibrium of boronic acids affecting lipophilicity measurements.

## Experimental Protocol: HPLC-Based Determination (CHI Method)

To bypass the boroxine artifact, Reversed-Phase HPLC is the gold standard. This method correlates retention time (

) to lipophilicity, preventing high concentrations that favor trimerization.

## Methodology: Chromatographic Hydrophobicity Index (CHI)

Objective: Determine the lipophilicity of 2,4-diethoxypyrimidine-5-boronic acid relative to the dimethoxy analog without interference from boroxine formation.

### Reagents & Equipment

- System: Agilent 1200 Series (or equivalent) with DAD detector.
- Column: C18 Reverse Phase (e.g., Luna C18, 50 x 3 mm, 3  $\mu$ m).
- Mobile Phase A: 50 mM Ammonium Acetate (pH 7.4) — Buffers the boronate equilibrium.
- Mobile Phase B: Acetonitrile (ACN).
- Standards: A set of 5-7 compounds with known LogP values (e.g., Theophylline, Toluene, Triphenylene).

### Step-by-Step Workflow

- Preparation of Standards:
  - Dissolve calibration standards in MeOH/Water (1:1) at 0.5 mg/mL.
  - Note: Avoid dissolving boronic acids in pure alcohol for long periods to prevent esterification.
- Preparation of Analytes:

- Dissolve the Dimethoxy and Diethoxy boronic acids in DMSO (10 mM stock).
- Dilute to 100  $\mu$ M in Mobile Phase A immediately before injection.
- Fast Gradient Run:
  - Flow: 1.0 mL/min.
  - Gradient: 0% B to 100% B over 5 minutes.
  - Detection: UV at 254 nm (pyrimidine absorption).
- Calculation:
  - Plot  
  
of standards vs. their known CHI or LogP values.
  - Derive the regression equation:  
  
.
  - Calculate LogP for the pyrimidine boronic acids based on their retention times.

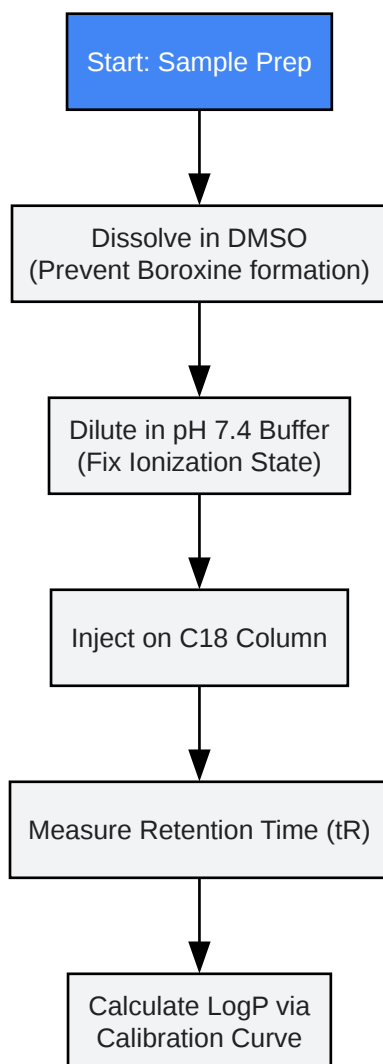

[Click to download full resolution via product page](#)

Figure 3: HPLC workflow for accurate lipophilicity determination.

## Synthetic & Biological Implications

### Data Comparison Table

Feature	Dimethoxy Analog	Diethoxy Analog	Impact
Predicted LogP	~0.5 - 0.8	~1.5 - 1.8	Diethoxy is ~10x more lipid soluble.
Aqueous Solubility	High	Moderate/Low	Dimethoxy prefers aqueous workups.
Suzuki Coupling	Efficient in Water/Alcohol	Requires Dioxane/Toluene	Diethoxy needs lipophilic solvents.
Metabolic Liability	O-Demethylation (Slow)	O-Deethylation (Fast)	Diethoxy may have shorter half-life.

## Strategic Selection

- Choose Dimethoxy if you are designing a fragment for a hydrophilic pocket or require high solubility for an intravenous formulation.
- Choose Diethoxy if you need to cross the Blood-Brain Barrier (BBB) or if the dimethoxy analog shows poor membrane permeability in Caco-2 assays.

## References

- Hansch, C., & Leo, A. (1979). *Substituent Constants for Correlation Analysis in Chemistry and Biology*. Wiley-Interscience. (Foundational text on methylene group contributions to LogP).
- Spring, D. R., et al. (2020). "The Boroxine–Boronic Acid Equilibrium." [1] University of Edinburgh Research Explorer. [Link](#)
- Valko, K., et al. (1997). "Fast Gradient HPLC Method to Determine Compounds' Lipophilicity." *Journal of Chromatography A*. (Establishes the CHI method for polar compounds).
- Hall, D. G. (2011). *Boronic Acids: Preparation and Applications in Organic Synthesis, Medicine and Materials*. Wiley-VCH. (Authoritative source on boronic acid stability and handling).
- BenchChem. (2025). "2,4-Dimethoxypyrimidine-5-boronic acid Technical Guide." [Link](#)

### Need Custom Synthesis?

BenchChem offers custom synthesis for rare earth carbides and specific isotopic labeling.

Email: [info@benchchem.com](mailto:info@benchchem.com) or [Request Quote Online](#).

## Sources

- 1. The Boroxine-Boronic Acid Equilibrium | Article Information | J-GLOBAL [[jglobal.jst.go.jp](http://jglobal.jst.go.jp)]
- To cite this document: BenchChem. [Lipophilicity Modulation in Pyrimidine Boronic Acids: A Comparative Technical Guide]. BenchChem, [2026]. [Online PDF]. Available at: [<https://www.benchchem.com/product/b11891454/docs#lipophilicity-modulation-in-pyrimidine-boronic-acids-a-comparative-technical-guide>]

### Disclaimer & Data Validity:

The information provided in this document is for Research Use Only (RUO) and is strictly not intended for diagnostic or therapeutic procedures. While BenchChem strives to provide accurate protocols, we make no warranties, express or implied, regarding the fitness of this product for every specific experimental setup.

**Technical Support:** The protocols provided are for reference purposes. Unsure if this reagent suits your experiment?

**Need Industrial/Bulk Grade?** [Request Custom Synthesis Quote](#)

## BenchChem

Our mission is to be the trusted global source of essential and advanced chemicals, empowering scientists and researchers to drive progress in science and industry.

### Contact

Address: 3281 E Guasti Rd

Ontario, CA 91761, United States

Phone: (601) 213-4426

Email: [info@benchchem.com](mailto:info@benchchem.com)

Contact our Ph.D. Support Team for a compatibility check