

Application Notes and Protocols: Strategic Thioamide Formation in Spirocyclic Scaffolds

Author: BenchChem Technical Support Team. **Date:** May 2026

Compound of Interest

Compound Name: *1-Oxaspiro[4.5]decane-4-carbothioamide, 2-oxo-*

CAS No.: 137180-69-9

Cat. No.: B11891422

[Get Quote](#)

Introduction: The Rising Prominence of Thioamides in Spirocyclic Drug Candidates

Spirocyclic frameworks have emerged as a privileged structural motif in modern drug discovery. Their inherent three-dimensionality offers a compelling strategy to escape the "flatland" of traditional aromatic compounds, enabling more precise and selective interactions with biological targets.[1] Within these complex architectures, the thioamide functional group serves as a crucial bioisostere of the amide bond.[2][3][4] The substitution of a carbonyl oxygen with sulfur imparts unique physicochemical properties, including altered hydrogen bonding capabilities, increased metabolic stability, and enhanced target affinity.[3][4] These attributes make the strategic incorporation of thioamides into spirocyclic drug candidates a compelling avenue for medicinal chemists to modulate pharmacokinetic and pharmacodynamic profiles.[3][5]

This guide provides a comprehensive overview of the reagents and catalysts employed for thioamide formation, with a specific focus on their application to the sterically demanding and functionally diverse landscape of spirocyclic compounds. We will delve into the mechanistic

underpinnings of these transformations, offering field-proven insights to navigate the challenges associated with these complex syntheses.

Core Principles of Thionation in Complex Molecular Architectures

The conversion of an amide to a thioamide, known as thionation, is a cornerstone of this synthetic strategy. When approaching the thionation of spirocyclic lactams or amides, several key factors must be considered:

- **Steric Hindrance:** The quaternary spirocyclic center can significantly impede the approach of bulky thionating reagents to the amide carbonyl.
- **Functional Group Compatibility:** Spirocyclic molecules often possess a high density of functional groups. The chosen reagent must exhibit high chemoselectivity to avoid unwanted side reactions.
- **Reaction Conditions:** Harsh reaction conditions can lead to epimerization, rearrangement, or degradation of the complex spirocyclic core.

A thorough understanding of the available reagents and their mechanisms is paramount to selecting the optimal conditions for a given spirocyclic substrate.

Stoichiometric Thionating Reagents: The Workhorses of Thioamide Synthesis

Lawesson's Reagent: A Mild and Versatile Option

Lawesson's reagent (LR) is a widely used thionating agent, valued for its mild reaction conditions and broad functional group tolerance.^{[6][7][8][9]} It is particularly well-suited for complex and sensitive substrates, such as those found in natural product synthesis and drug discovery.^[8]

Mechanism of Action: Lawesson's reagent exists in equilibrium with a reactive dithiophosphine ylide intermediate. This intermediate undergoes a [2+2] cycloaddition with the amide carbonyl to form a transient thioxaphosphetane ring. Subsequent cycloreversion, driven by the formation of a stable P=O bond, yields the desired thioamide.^{[6][7][10]}

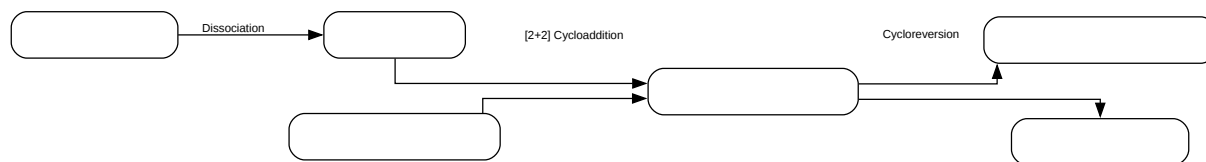

[Click to download full resolution via product page](#)

Figure 1: Mechanism of Thionation with Lawesson's Reagent.

Key Considerations for Spirocyclic Systems:

- **Solvent Choice:** Toluene and xylene are commonly used solvents for reactions with Lawesson's reagent, often requiring elevated temperatures. For heat-sensitive spirocyclic compounds, dichloromethane (DCM) or tetrahydrofuran (THF) may be employed, although longer reaction times may be necessary.
- **Stoichiometry:** While 0.5 equivalents of LR are theoretically sufficient, a slight excess (0.6-1.0 equivalents) is often used to drive the reaction to completion, especially with sterically hindered substrates.
- **Microwave Irradiation:** Microwave-assisted synthesis can significantly accelerate the thionation process, often leading to cleaner reactions and higher yields in shorter timeframes.^[11] This can be particularly advantageous for preventing the degradation of complex spirocyclic molecules.^[11]

Protocol 1: General Procedure for Thionation of a Spirocyclic Lactam using Lawesson's Reagent

- To a solution of the spirocyclic lactam (1.0 mmol) in anhydrous toluene (10 mL) under an inert atmosphere (N₂ or Ar), add Lawesson's reagent (0.6 mmol, 0.6 eq).
- Heat the reaction mixture to 80-110 °C and monitor the progress by thin-layer chromatography (TLC) or liquid chromatography-mass spectrometry (LC-MS).

- Upon completion, cool the reaction mixture to room temperature and concentrate under reduced pressure.
- Purify the crude product by flash column chromatography on silica gel to afford the desired spirocyclic thiolactam.

Phosphorus Pentasulfide (P_4S_{10}): A Powerful, Classical Reagent

Phosphorus pentasulfide is a highly effective, albeit aggressive, thionating agent.^{[8][12]} Its high reactivity often necessitates harsher conditions, which may not be suitable for all spirocyclic substrates.^[6] However, for robust systems, P_4S_{10} can be a cost-effective and efficient option.^{[13][14]}

Key Considerations for Spirocyclic Systems:

- **Reactivity and Selectivity:** The high reactivity of P_4S_{10} can lead to side reactions with other functional groups. Its use in functionally dense spirocycles requires careful optimization.
- **Solvent and Temperature:** Reactions are typically carried out in high-boiling solvents like pyridine or xylene at reflux temperatures.^{[14][15]}
- **P_4S_{10} /HMDO System:** The combination of P_4S_{10} with hexamethyldisiloxane (HMDO) can offer a milder alternative, with improved solubility of the reagent and often leading to cleaner reactions and easier workup.^[16]

Protocol 2: Thionation using P_4S_{10} /Hexamethyldisiloxane (HMDO)

- In a flame-dried flask under an inert atmosphere, suspend P_4S_{10} (0.5 mmol, 0.5 eq) in anhydrous acetonitrile (5 mL).
- Add hexamethyldisiloxane (HMDO) (1.0 mmol, 1.0 eq) and stir the mixture at room temperature for 15 minutes.
- Add a solution of the spirocyclic amide (1.0 mmol) in anhydrous acetonitrile (5 mL).

- Heat the reaction mixture to reflux and monitor its progress.
- After completion, cool the reaction to room temperature and quench by the slow addition of saturated aqueous NaHCO₃ solution.
- Extract the aqueous layer with ethyl acetate, combine the organic layers, wash with brine, dry over anhydrous Na₂SO₄, and concentrate in vacuo.
- Purify the residue by flash chromatography.

Catalytic Approaches to Thioamide Formation

While stoichiometric reagents are prevalent, the development of catalytic methods for thioamide synthesis is an area of growing interest, offering advantages in terms of atom economy and milder reaction conditions.

Elemental Sulfur with a Catalytic Base

Recent advancements have demonstrated the use of elemental sulfur (S₈) in the presence of a catalytic amount of a base, such as sodium sulfide (Na₂S), for the synthesis of thioamides.^[17] This approach is attractive due to the low cost and low toxicity of elemental sulfur.

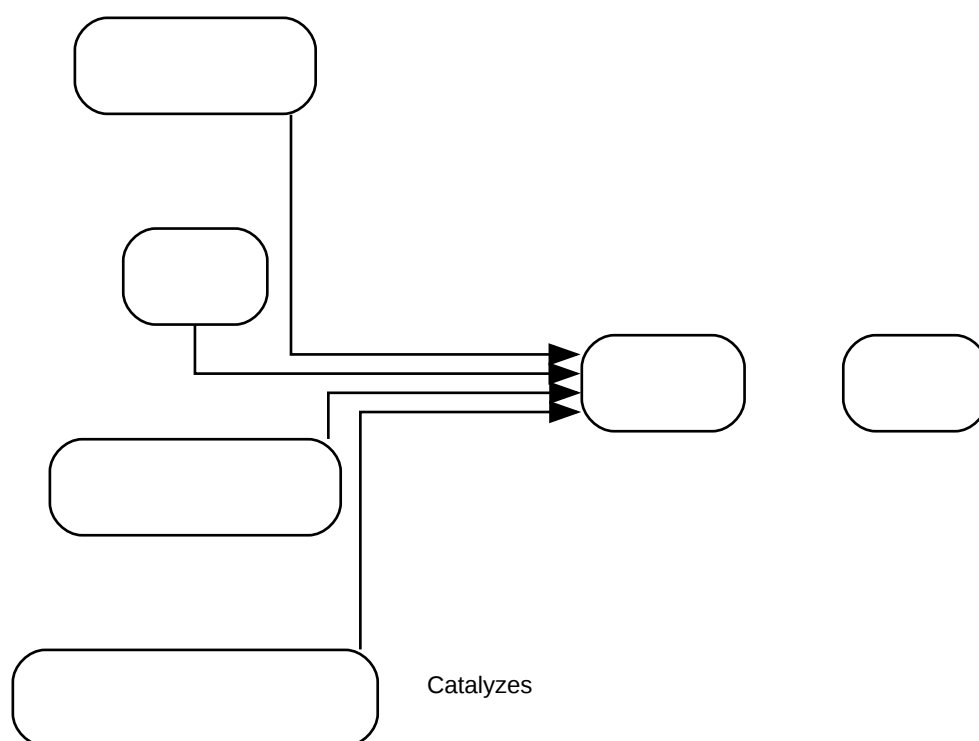

[Click to download full resolution via product page](#)

Figure 2: Conceptual Workflow for Catalytic Thioamide Synthesis.

Key Considerations for Spirocyclic Systems:

- **Substrate Scope:** This method is often employed in multicomponent reactions, for instance, from an aldehyde, an amine, and sulfur.[2][18] Its direct application to pre-formed spirocyclic amides is less common but warrants investigation.
- **Reaction Conditions:** These reactions are often performed under neat conditions or in a minimal amount of a high-boiling solvent.

Comparative Analysis of Thionation Reagents

The choice of thionating reagent is critical and depends heavily on the specific spirocyclic substrate. Below is a comparative table to guide reagent selection.

Reagent/System	Typical Conditions	Advantages	Disadvantages	Suitability for Spirocycles
Lawesson's Reagent	Toluene or DCM, 80-110°C	Mild, good functional group tolerance, high yields.[6][8]	Byproduct removal can be challenging.[16]	High, especially for sensitive and complex molecules.
P ₄ S ₁₀	Pyridine or Xylene, reflux	Highly reactive, cost-effective.[8][14]	Harsh conditions, potential for side reactions.[6]	Moderate, best for robust spirocyclic cores.
P ₄ S ₁₀ /HMDO	Acetonitrile, reflux	Milder than P ₄ S ₁₀ alone, easier workup.[16]	Requires optimization for each substrate.	Good, offers a balance of reactivity and mildness.
Elemental Sulfur/Base	Neat or high-boiling solvent	Atom economical, inexpensive reagent.[17]	Primarily for multicomponent synthesis, not direct thionation of amides.	Low for direct thionation of spirocyclic amides.

Troubleshooting and Optimization

- **Low Yields:** Increase the reaction temperature, reaction time, or the amount of thionating reagent. Consider switching to a more reactive reagent if the substrate is robust. Microwave irradiation can also improve yields.
- **Side Reactions:** Decrease the reaction temperature or use a milder reagent like Lawesson's reagent. Ensure the starting material is pure and the reaction is performed under an inert atmosphere.
- **Difficult Purification:** For reactions using Lawesson's reagent, a modified workup involving an aqueous wash with NaOH or ethylene glycol treatment can help remove the phosphorus-containing byproducts.[19] The P₄S₁₀/HMDO system is also known for a simpler workup.[16]

Conclusion

The synthesis of thioamides in spirocyclic compounds is a vital transformation for the development of novel therapeutics. While Lawesson's reagent remains a reliable and versatile choice for complex substrates, a careful evaluation of the spirocyclic system's stability and functional group array is crucial for selecting the optimal thionation strategy. The ongoing development of milder reagents and catalytic systems promises to further expand the synthetic chemist's toolbox for accessing these valuable and intricate molecules.

References

- Mitchell, J. P., & Mitchell, I. S. (Year). Biosynthesis and Chemical Applications of Thioamides.
- (2020).
- (2023).
- Lawesson's Reagent. Organic Chemistry Portal.
- (2024). Contemporary Applications of Thioamides and Methods for Their Synthesis.
- Hansen, T. N., & Olsen, C. A. (2024). Contemporary Applications of Thioamides and Methods for Their Synthesis. PubMed.
- (2021). A Focused Review of Synthetic Applications of Lawesson's Reagent in Organic Synthesis.
- Chemoselective Transamidation of Thioamides by Transition-Metal-Free N–C(S)
- (2025). Mild Method for the Conversion of Amides to Thioamides.
- Transformation of Amides to Thioamides Using an Efficient and Novel Thi
- Liquid-assisted mechanochemical synthesis of thioamide building blocks with the Lawesson reagent: ex situ monitoring and detection of intermedi
- Nitroalkanes as thioacyl equivalents to access thioamides and thiopeptides. PMC - NIH.
- (2020). Catalytic Hydrogenation of Thioesters, Thiocarbamates, and Thioamides.
- Mechanism of amide thiocarbonylation via Lawesson's reagent.
- A Comparative Guide to Alternative Reagents for Thioamide Synthesis. Benchchem.
- Synthetic Applications of Lawesson's Reagent in Organic Synthesis. Encyclopedia.pub.
- (2016). Computational Mechanistic Study of Thionation of Carbonyl Compounds with Lawesson's Reagent.
- (2024).
- Lawesson's reagent. Wikipedia.
- (2025). A Simple and Effective Method for the Thionation of Amides to Thioamides Using Al₂O₃-Supported P₄S₁₀.
- Synthetic Routes to Approved Drugs Containing a Spirocycle. PMC - NIH.
- Thioamide synthesis by thion
- (2021). A Focused Review of Synthetic Applications of Lawesson's Reagent in Organic Synthesis.

- (Year). Thionation with the reagent combination of phosphorus pentasulfide and hexamethyldisiloxane. PubMed.
- Lawesson's Reagent. Alfa Chemistry.
- Microwave-Assisted Thioamide Synthesis: Research Guide & Papers. PapersFlow.
- (Year).
- Thioamide synthesis by thioacyl
- (2025). A Berzelius Reagent, Phosphorus Decasulfide (P₄S₁₀), in Organic Syntheses.
- Synthetic Routes to Approved Drugs Containing a Spirocycle.

Need Custom Synthesis?

BenchChem offers custom synthesis for rare earth carbides and specific isotopic labeling.

Email: info@benchchem.com or [Request Quote Online](#).

Sources

1. [researchgate.net](https://www.researchgate.net) [[researchgate.net](https://www.researchgate.net)]
2. Towards More Practical Methods for the Chemical Synthesis of Thioamides Using Sulfuration Agents: A Decade Update [[mdpi.com](https://www.mdpi.com)]
3. [researchgate.net](https://www.researchgate.net) [[researchgate.net](https://www.researchgate.net)]
4. Contemporary Applications of Thioamides and Methods for Their Synthesis - PubMed [pubmed.ncbi.nlm.nih.gov]
5. Thioamides: Biosynthesis of Natural Compounds and Chemical Applications - PMC [[pmc.ncbi.nlm.nih.gov](https://pubmed.ncbi.nlm.nih.gov)]
6. Lawesson's Reagent [[organic-chemistry.org](https://www.organic-chemistry.org)]
7. Lawesson's reagent - Wikipedia [en.wikipedia.org]
8. A Focused Review of Synthetic Applications of Lawesson's Reagent in Organic Synthesis - PMC [[pmc.ncbi.nlm.nih.gov](https://pubmed.ncbi.nlm.nih.gov)]
9. [alfa-chemistry.com](https://www.alfa-chemistry.com) [[alfa-chemistry.com](https://www.alfa-chemistry.com)]
10. [researchgate.net](https://www.researchgate.net) [[researchgate.net](https://www.researchgate.net)]
11. [papersflow.ai](https://www.papersflow.ai) [[papersflow.ai](https://www.papersflow.ai)]
12. [encyclopedia.pub](https://www.encyclopedia.pub) [[encyclopedia.pub](https://www.encyclopedia.pub)]
13. [benchchem.com](https://www.benchchem.com) [[benchchem.com](https://www.benchchem.com)]

- [14. researchgate.net \[researchgate.net\]](#)
- [15. Transformation of Amides to Thioamides Using an Efficient and Novel Thiating Reagent - PMC \[pmc.ncbi.nlm.nih.gov\]](#)
- [16. Thionation with the reagent combination of phosphorus pentasulfide and hexamethyldisiloxane - PubMed \[pubmed.ncbi.nlm.nih.gov\]](#)
- [17. mdpi.com \[mdpi.com\]](#)
- [18. Thioamide synthesis by thioacylation \[organic-chemistry.org\]](#)
- [19. mdpi.com \[mdpi.com\]](#)
- To cite this document: BenchChem. [Application Notes and Protocols: Strategic Thioamide Formation in Spirocyclic Scaffolds]. BenchChem, [2026]. [Online PDF]. Available at: [\[https://www.benchchem.com/product/b11891422/docs#application-notes-and-protocols-strategic-thioamide-formation-in-spirocyclic-scaffolds\]](https://www.benchchem.com/product/b11891422/docs#application-notes-and-protocols-strategic-thioamide-formation-in-spirocyclic-scaffolds)

Disclaimer & Data Validity:

The information provided in this document is for Research Use Only (RUO) and is strictly not intended for diagnostic or therapeutic procedures. While BenchChem strives to provide accurate protocols, we make no warranties, express or implied, regarding the fitness of this product for every specific experimental setup.

Technical Support: The protocols provided are for reference purposes. Unsure if this reagent suits your experiment?

Need Industrial/Bulk Grade? [Request Custom Synthesis Quote](#)

BenchChem

Our mission is to be the trusted global source of essential and advanced chemicals, empowering scientists and researchers to drive progress in science and industry.

Contact

Address: 3281 E Guasti Rd
Ontario, CA 91761, United States
Phone: (601) 213-4426
Email: info@benchchem.com

Contact our Ph.D. Support Team for a compatibility check