

# Advanced Comparison Guide: Solar Cell Efficiency and Stability Across Different Anchor Groups

**Author:** BenchChem Technical Support Team. **Date:** April 2026

## Compound of Interest

Compound Name:	5-Methyl-[2,3'-bipyridine]-5'-carboxylic acid
CAS No.:	1346686-72-3
Cat. No.:	B11890059

[Get Quote](#)

As photovoltaic technologies evolve from traditional Dye-Sensitized Solar Cells (DSSCs) to highly efficient Inverted Perovskite Solar Cells (IPSCs), the interface between the photoactive layer and the charge transport layer remains the primary bottleneck for device performance. At the heart of this interface is the anchor group—a chemical moiety responsible for binding the light-harvesting molecule or hole-transporting self-assembled monolayer (SAM) to the metal oxide substrate.

As an application scientist, I often see researchers select anchor groups based solely on precedent rather than mechanistic fit. This guide provides an objective, data-driven comparison of the most prominent anchor groups, explaining the causality behind their performance differences and detailing self-validating protocols for their application.

## Mechanistic Causality: The Dual Role of the Anchor Group

An effective anchor group must perform two competing functions simultaneously:

- **Thermodynamic Adsorption:** It must form robust covalent or ionic bonds (e.g., ester, chelating, or bidentate linkages) with the hydroxylated surface of metal oxides ( $\text{TiO}_2$ ,  $\text{NiO}_x$ , ITO) to ensure long-term device stability.
- **Electronic Coupling:** It must facilitate strong orbital overlap. In DSSCs, this means bridging the Lowest Unoccupied Molecular Orbital (LUMO) of the dye with the Conduction Band (CB) of the semiconductor. In IPSCs, it involves tuning the work function of the substrate via dipole moments to match the perovskite's valence band.

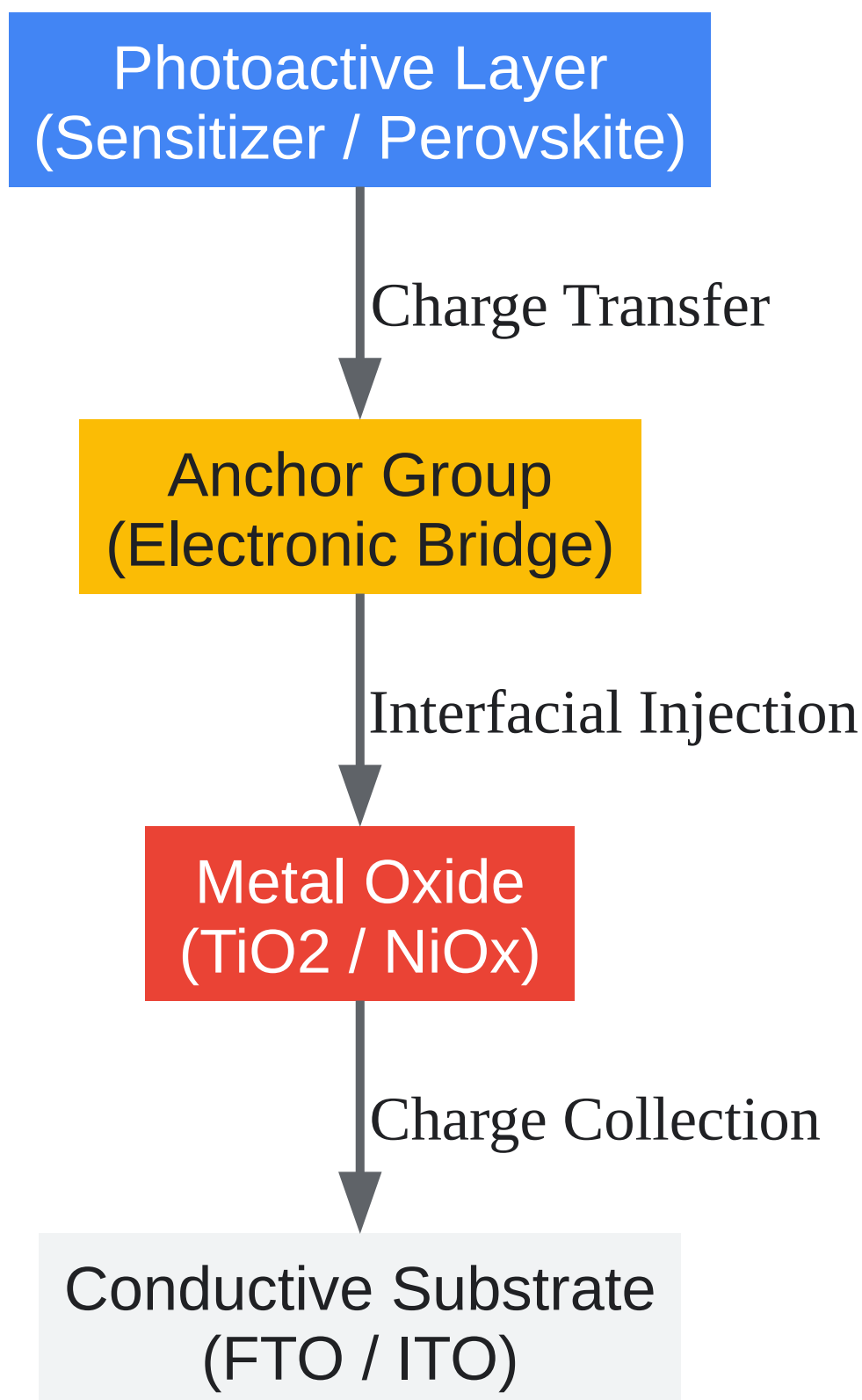

[Click to download full resolution via product page](#)

*Charge transfer pathway from sensitizer through the anchor group to the electrode.*

## Comparative Analysis of Key Anchor Groups

### Carboxylic Acid (-COOH)

Historically the gold standard for DSSCs, carboxylic acids bind to  $\text{TiO}_2$  via ester or chelating linkages.

- **The Advantage:** They provide excellent electronic coupling. The  $\text{sp}^2$  hybridization of the carboxylate carbon allows for extended  $\pi$ -conjugation, resulting in ultrafast electron injection times[1].
- **The Drawback:** Carboxylate bonds are highly susceptible to hydrolysis. In the presence of trace water or under long-term thermal stress, the dye easily desorbs from the semiconductor surface, severely limiting the commercial lifespan of the device[2].

### Cyanoacrylic Acid

Widely utilized in modern organic D- $\pi$ -A (Donor-Pi-Acceptor) dyes.

- **The Advantage:** The addition of the cyano (-CN) group acts as a powerful electron-withdrawing moiety. This pulls electron density toward the anchor, stabilizing the LUMO and extending the spectral response (red-shifting) of the dye to capture more near-infrared photons. It is the most commonly reported anchoring group for high-efficiency organic DSSCs[3].

### Phosphonic Acid (- $\text{PO}_3\text{H}_2$ )

Phosphonic acids are the undisputed champions of stability and are currently revolutionizing SAM-based Perovskite Solar Cells.

- **The Advantage:** They bind to metal oxides via robust tridentate P-O-M bonds. Experimental data shows that phosphonic acid anchors desorb 5 to 1000 times more slowly than carboxylic acids[4]. In inverted PSCs, phosphonic acid SAMs (like Me-4PACz) create a permanent dipole moment that perfectly aligns the work function of ITO with the perovskite layer, passivating interfacial defects and pushing power conversion efficiencies (PCE) beyond 26%[5].

- The Drawback: In traditional DSSCs, the tetrahedral ( $sp^3$ ) geometry of the phosphorus atom breaks the  $\pi$ -conjugation between the dye and the  $TiO_2$  surface. This leads to weaker interfacial electronic coupling and electron injection times that are roughly twice as slow as those of carboxylic acids[1].

## Quantitative Efficiency & Stability Comparison

The following table synthesizes experimental data comparing these anchor groups across different device architectures.

Anchor Group	Primary Application	Binding Motif	Desorption Resistance	Electronic Coupling	Typical Device Efficiency
Carboxylic Acid	DSSCs (Ru-dyes)	Ester / Chelating	Low (Hydrolyzes easily)	Excellent (Fast injection)	10.0% - 14.0%
Cyanoacrylic Acid	DSSCs (Organic D- $\pi$ -A)	Chelating	Moderate	Excellent (Extended $\pi$ )	12.0% - 14.7%
Phosphonic Acid	DSSCs (High Stability)	Tridentate (P-O-M)	Very High	Moderate (Slower injection)	4.0% - 5.0%
Phosphonic Acid	IPSCs (SAM HTLs)	Tridentate (P-O-M)	Very High	Excellent (Work function tuning)	> 26.0%

## Experimental Workflow: Self-Validating Monolayer Deposition

To achieve the efficiencies listed above, the deposition protocol cannot be treated as a simple "dip and dry" procedure. The following step-by-step methodology ensures a self-validating system for depositing phosphonic or carboxylic acid SAMs/dyes onto metal oxide substrates.

## Step-by-Step Methodology

### Step 1: Substrate Activation (Hydroxyl Generation)

- Action: Treat the FTO/ITO or metal oxide substrates with UV-Ozone or O<sub>2</sub> plasma for 15 minutes immediately prior to deposition.
- Causality: Anchor groups require active surface hydroxyl (-OH) sites to undergo condensation reactions. Without this activation, the anchor will only physisorb via weak Van der Waals forces rather than forming covalent M-O-P or M-O-C bonds.

### Step 2: Monolayer Adsorption

- Action: Immerse the activated substrate into a 0.5 - 1.0 mM solution of the anchor-functionalized molecule (e.g., Me-4PACz in ethanol) for 2 to 12 hours at room temperature.
- Causality: Low concentrations prevent rapid, disordered aggregation, allowing the molecules to thermodynamically self-assemble into a dense, vertically aligned monolayer.

### Step 3: Aggressive Solvent Wash (Critical Step)

- Action: Remove the substrate and immediately spin-rinse or sonicate in the neat deposition solvent (e.g., pure ethanol) for 30 seconds.
- Causality: This removes physisorbed multilayers. Excess unbound molecules act as an insulating barrier, disrupting charge tunneling and severely reducing the fill factor (FF) of the final device.

### Step 4: Surface Validation (The Self-Validating Check)

- Action: Measure the water contact angle of the dried substrate.
- Causality: A successful SAM deposition will drastically alter the wettability of the surface. For example, a bare, UV-treated ITO surface is highly hydrophilic (< 10°). A successfully anchored carbazole-phosphonic acid SAM will shift the contact angle to ~60-80°, definitively proving surface modification without requiring vacuum-based XPS characterization.

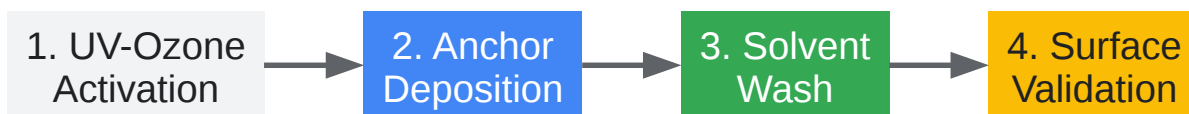

[Click to download full resolution via product page](#)

*Step-by-step experimental workflow for anchor group deposition and validation.*

## References

- Anchoring Groups for Dye-Sensitized Solar Cells ACS Applied Materials & Interfaces[[Link](#)][2]
- Computational Investigation of Dye-Sensitized Solar Cells Uppsala University (Diva-portal) [[Link](#)][1]
- A Comprehensive Review of Self-Assembled Monolayers as Hole-Transport Layers in Inverted Perovskite Solar Cells MDPI[[Link](#)][5]
- Self-assembled monolayers as hole-transporting materials for inverted perovskite solar cells Molecular Systems Design & Engineering (RSC Publishing)[[Link](#)][6]
- A perspective on using experiment and theory to identify design principles in dye-sensitized solar cells Taylor & Francis[[Link](#)][4]
- Anchoring Groups for Dye-Sensitized Solar Cells (ResearchGate Overview) ResearchGate[[Link](#)][3]

### *Need Custom Synthesis?*

*BenchChem offers custom synthesis for rare earth carbides and specific isotopic labeling.*

*Email: [info@benchchem.com](mailto:info@benchchem.com) or [Request Quote Online](#).*

## Sources

- [1. diva-portal.org \[diva-portal.org\]](https://diva-portal.org)
- [2. pubs.acs.org \[pubs.acs.org\]](https://pubs.acs.org)

- [3. researchgate.net \[researchgate.net\]](#)
- [4. tandfonline.com \[tandfonline.com\]](#)
- [5. mdpi.com \[mdpi.com\]](#)
- [6. Self-assembled monolayers as hole-transporting materials for inverted perovskite solar cells - Molecular Systems Design & Engineering \(RSC Publishing\) DOI:10.1039/D3ME00144J \[pubs.rsc.org\]](#)
- To cite this document: BenchChem. [Advanced Comparison Guide: Solar Cell Efficiency and Stability Across Different Anchor Groups]. BenchChem, [2026]. [Online PDF]. Available at: [<https://www.benchchem.com/product/b11890059/docs#advanced-comparison-guide-solar-cell-efficiency-and-stability-across-different-anchor-groups>]

---

### Disclaimer & Data Validity:

The information provided in this document is for Research Use Only (RUO) and is strictly not intended for diagnostic or therapeutic procedures. While BenchChem strives to provide accurate protocols, we make no warranties, express or implied, regarding the fitness of this product for every specific experimental setup.

**Technical Support:** The protocols provided are for reference purposes. Unsure if this reagent suits your experiment?

**Need Industrial/Bulk Grade?** [Request Custom Synthesis Quote](#)

## BenchChem

Our mission is to be the trusted global source of essential and advanced chemicals, empowering scientists and researchers to drive progress in science and industry.

### Contact

Address: 3281 E Guasti Rd  
Ontario, CA 91761, United States  
Phone: (601) 213-4426  
Email: [info@benchchem.com](mailto:info@benchchem.com)

Contact our Ph.D. Support Team for a compatibility check