

# Suzuki-Miyaura Coupling Support Center: Mitigating Protodeboronation

**Author:** BenchChem Technical Support Team. **Date:** May 2026

## Compound of Interest

Compound Name: (5'-Methyl-[2,2'-bithiophen]-5-yl)boronic acid

CAS No.: 918412-93-8

Cat. No.: B11885633

[Get Quote](#)

## Topic: Troubleshooting Boronic Acid Instability & Deboronation

### Diagnostic Module: Is it Deboronation?

Before altering reaction parameters, confirm that the yield loss is due to protodeboronation and not catalyst deactivation or homocoupling.

The Symptom:

- Low conversion of the aryl halide.
- The aryl halide remains unreacted.
- Crucial Indicator: LCMS or GCMS shows a major byproduct corresponding to the mass of the boronic acid minus the boron moiety, replaced by a proton ( ).

The "Silent Killer" Mechanism: Protodeboronation is not a random decomposition; it is a competitive pathway driven by the boronate anion. Under basic conditions (required for transmetalation), the boronic acid forms a boronate "ate" complex. While this species is necessary for the reaction, it is also the species that undergoes hydrolysis/protonolysis.

## Visualizing the Competition

The following diagram illustrates the "Fork in the Road" where your reaction succeeds or fails.

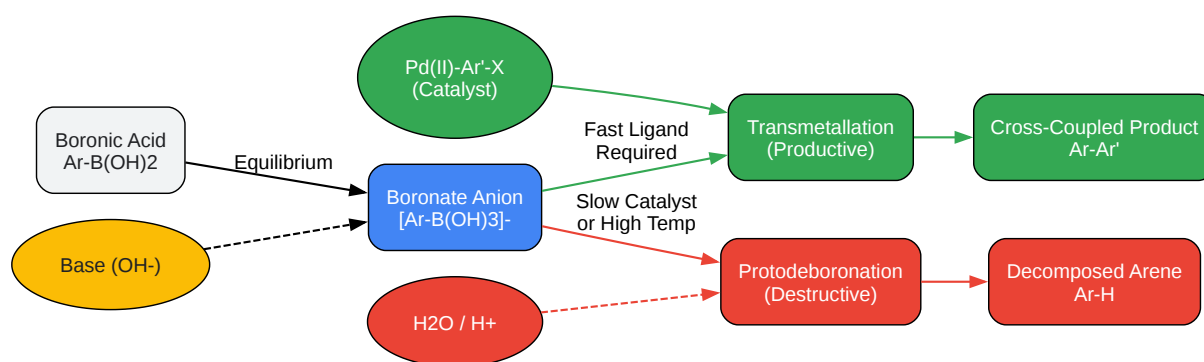

[Click to download full resolution via product page](#)

Figure 1: The Kinetic Competition. The boronate anion is required for both the desired reaction (Green) and the destructive deboronation (Red).

## Troubleshooting Guides & FAQs

### Q1: My 2-pyridineboronic acid yields are near zero. Why is this specific substrate failing?

Technical Insight: 2-Heterocyclic boronic acids (2-pyridyl, 2-thiazolyl) are uniquely unstable. Unlike phenyl rings, the nitrogen lone pair in the pyridine ring stabilizes the negative charge on the carbon during the transition state, accelerating C-B bond cleavage. This often proceeds via

a unimolecular fragmentation of a zwitterionic intermediate, which is extremely rapid at neutral pH.<sup>[1]</sup>

The Fix: Switch to MIDA Boronates. Standard boronic acids are often too unstable for these couplings. Use N-methyliminodiacetic acid (MIDA) boronates.<sup>[2][3][4][5]</sup> The MIDA ligand rehybridizes the boron from

to

, removing the Lewis acidity and preventing the formation of the reactive boronate anion until it is slowly hydrolyzed in situ.

- Protocol: See Protocol B (Slow Release) below.
- Reference: Burke et al. (2009) demonstrated this as the primary solution for the "2-pyridyl problem."

## Q2: I am using K<sub>2</sub>CO<sub>3</sub> in Dioxane/Water. Should I switch to a stronger base like NaOH?

Technical Insight: NO. Increasing basicity (pH) generally accelerates protodeboronation. Cox et al. (2017) proved that the rate of deboronation correlates with the concentration of the boronate anion

. Stronger bases push the equilibrium entirely toward this unstable anion.

The Fix: Base Tuning.

- Lower the pH: Switch to (anhydrous or monohydrate) or .
- Anhydrous Conditions: If the substrate is extremely sensitive, water must be removed entirely. Hydrolytic deboronation cannot occur without protons.
  - Recommendation: Use TMSOK (Potassium Trimethylsilanolate) in THF or Toluene. This acts as an anhydrous hydroxide surrogate.

Base	pH (approx in H2O)	Risk of Deboronation	Recommended For
NaOH / KOH	>14	Critical	Only highly stable aryls
Cs2CO3	~12	High	Sterically hindered couplings
K3PO4	~11.5	Moderate	General purpose
KF	~8.5	Low	Sensitive heterocycles
TMSOK	N/A (Anhydrous)	Minimal	Unstable boronic esters

### Q3: Can the catalyst choice prevent deboronation?

Technical Insight: Yes, by kinetics. You cannot stop deboronation, but you can outrun it. If the rate of Transmetallation (

) is faster than the rate of Deboronation (

), you get product. Electron-rich, bulky phosphine ligands accelerate oxidative addition and transmetallation.

The Fix: The "Buchwald" Strategy. Switch to Pd-G3/G4 precatalysts containing dialkylbiaryl phosphines:

- XPhos: Excellent for general heteroaryl couplings.
- SPhos: Good for sterically hindered systems.
- P(t-Bu)<sub>3</sub> (Fu's Ligand): High reactivity for chlorides.

## Experimental Protocols

### Protocol A: The "Speed Run" (High Turnover)

Best for: Moderately unstable substrates where speed is key.

- Catalyst: XPhos Pd G4 (2-3 mol%).
- Base:  
(0.5 M aqueous solution, 2.0 equiv).
- Solvent: THF or 1,4-Dioxane (degassed).
- Temperature: 40–60 °C (Do not overheat; heat accelerates deboronation > transmetallation).
- Procedure:
  - Charge aryl halide (1.0 equiv) and boronic acid (1.5 equiv).[2]
  - Add degassed solvent and base.
  - Add catalyst last as a solid or stock solution.
  - Why? Ensures Pd enters the cycle immediately when heating starts.

## Protocol B: The "Slow Release" (MIDA Boronates)

Best for: 2-Pyridyl, Vinyl, and Cyclopropyl boronates.[2]

- Reagent: MIDA Boronate ester (1.2–1.5 equiv).
- Catalyst: Pd(OAc)<sub>2</sub> (2 mol%) + SPhos (4 mol%) OR XPhos Pd G3.
- Base:  
(anhydrous, 5.0 equiv).
- Solvent: 1,4-Dioxane / Water (10:1 ratio).
- Temperature: 60 °C.
- Mechanism: The low water content and sparing solubility of the base cause the MIDA boronate to hydrolyze slowly. The free boronic acid concentration never spikes, keeping the "destructive" pathway suppressed.

## Protocol C: Anhydrous TMSOK Method

Best for: Substrates that decompose instantly in water.

- Reagent: Pinacol Boronate Ester (Ar-Bpin).
- Base: Potassium Trimethylsilanolate (TMSOK) (1.5 equiv).
- Solvent: Anhydrous THF or DME.
- Catalyst: Pd(dppf)Cl<sub>2</sub> or Pd(PPh<sub>3</sub>)<sub>4</sub>.
- Note: TMSOK generates the active boronate species without water.

## Strategic Decision Logic

Use this logic flow to select your troubleshooting path.

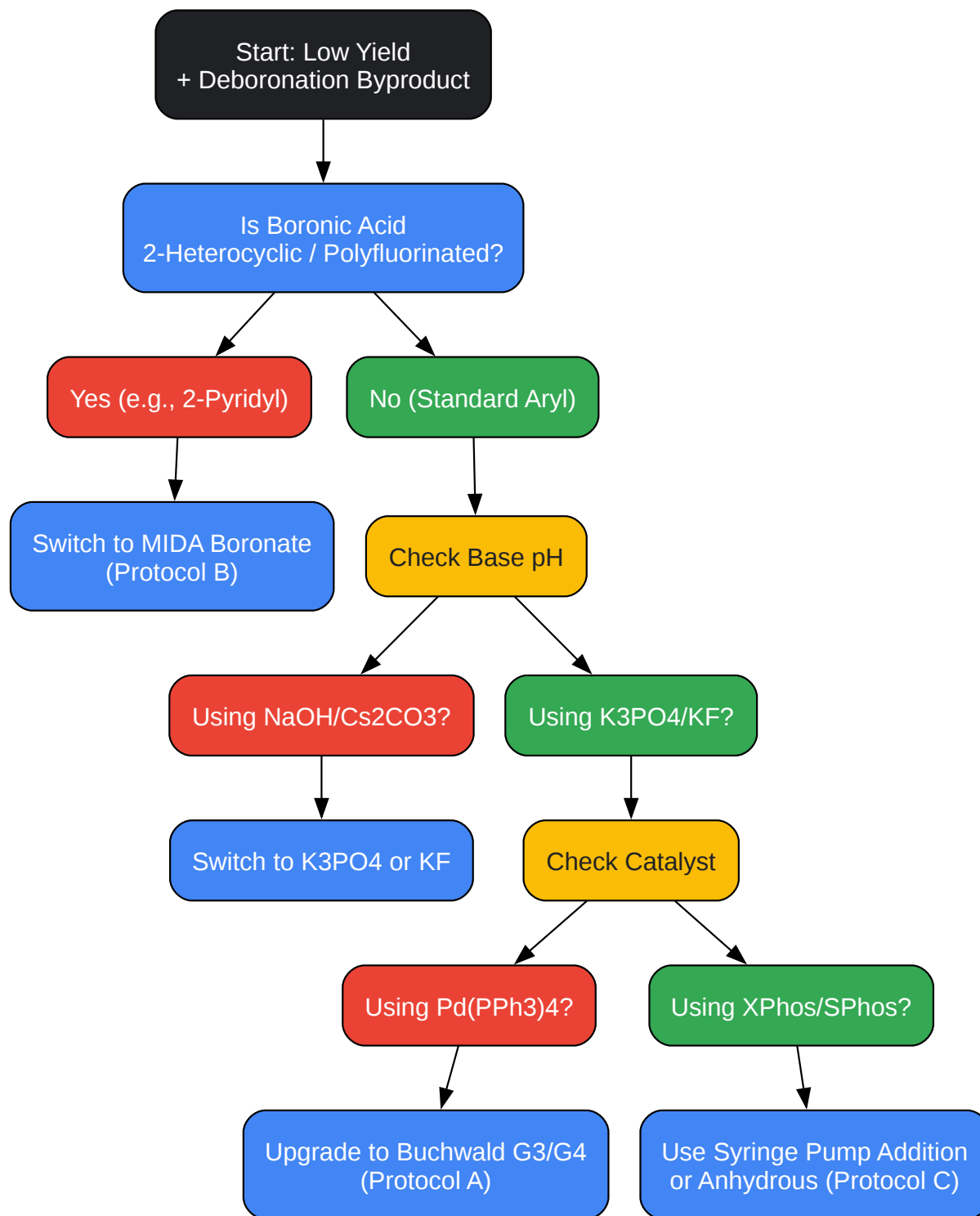

[Click to download full resolution via product page](#)

Figure 2: Troubleshooting Decision Matrix.

## References

- Cox, P. A., et al. (2017).[6] "Base-Catalyzed Aryl-B(OH)<sub>2</sub> Protodeboronation Revisited: From Concerted Proton Transfer to Liberation of a Transient Aryl Anion." *Journal of the American Chemical Society*.
- Knapp, D. M., Gillis, E. P., & Burke, M. D. (2009). "A General Solution for Unstable Boronic Acids: Slow-Release Cross-Coupling from Air-Stable MIDA Boronates." *Journal of the American Chemical Society*.
- Kassel, W. S., & Denmark, S. E. (2021).[7] "Anhydrous, Homogeneous, Suzuki-Miyaura Cross-Coupling of Boronic Esters using Potassium Trimethylsilanolate." *Organic Syntheses*.
- Kinzel, T., Zhang, Y., & Buchwald, S. L. (2010). "A New Palladium Precatalyst Allows for the Fast Suzuki–Miyaura Coupling Reactions of Unstable Polyfluorophenylboronic Acids." *Journal of the American Chemical Society*.

### Need Custom Synthesis?

BenchChem offers custom synthesis for rare earth carbides and specific isotopic labeling.

Email: [info@benchchem.com](mailto:info@benchchem.com) or [Request Quote Online](#).

## Sources

- [1. Protodeboronation - Wikipedia \[en.wikipedia.org\]](#)
- [2. pubs.acs.org \[pubs.acs.org\]](#)
- [3. ボロン酸MIDAエステル類 \[sigmaaldrich.com\]](#)
- [4. research.ed.ac.uk \[research.ed.ac.uk\]](#)
- [5. A General Solution for the 2-Pyridyl Problem - PMC \[pmc.ncbi.nlm.nih.gov\]](#)
- [6. researchgate.net \[researchgate.net\]](#)
- [7. Yoneda Labs \[yonedalabs.com\]](#)
- To cite this document: BenchChem. [Suzuki-Miyaura Coupling Support Center: Mitigating Protodeboronation]. BenchChem, [2026]. [Online PDF]. Available at:

[\[https://www.benchchem.com/product/b11885633/docs#suzuki-miyaura-coupling-support-center-mitigating-protodeboronation\]](https://www.benchchem.com/product/b11885633/docs#suzuki-miyaura-coupling-support-center-mitigating-protodeboronation)

### Disclaimer & Data Validity:

The information provided in this document is for Research Use Only (RUO) and is strictly not intended for diagnostic or therapeutic procedures. While BenchChem strives to provide accurate protocols, we make no warranties, express or implied, regarding the fitness of this product for every specific experimental setup.

**Technical Support:** The protocols provided are for reference purposes. Unsure if this reagent suits your experiment?

**Need Industrial/Bulk Grade?** [Request Custom Synthesis Quote](#)

## BenchChem

Our mission is to be the trusted global source of essential and advanced chemicals, empowering scientists and researchers to drive progress in science and industry.

### Contact

Address: 3281 E Guasti Rd  
Ontario, CA 91761, United States  
Phone: (601) 213-4426  
Email: [info@benchchem.com](mailto:info@benchchem.com)

[Contact our Ph.D. Support Team for a compatibility check](#)