

Technical Guide: Mass Spectrometry

Fragmentation of 3-Nitro-2,4-dimethoxyacetophenone

Author: BenchChem Technical Support Team. **Date:** May 2026

Compound of Interest

Compound Name:	1-(2,4-Dimethoxy-3-nitrophenyl)ethanone
CAS No.:	102652-87-9
Cat. No.:	B11882633

[Get Quote](#)

Executive Summary

This guide provides a comparative technical analysis of the mass spectrometric behavior of 3-Nitro-2,4-dimethoxyacetophenone (

, MW 225.19 Da). As a highly functionalized aromatic intermediate often encountered in the synthesis of chalcones and pharmacophores, its characterization requires a nuanced understanding of competing fragmentation pathways.

We compare two primary ionization modalities: Electron Ionization (EI) and Electrospray Ionization (ESI-MS/MS).[1] While EI provides a structural "fingerprint" driven by radical-cation chemistry, ESI offers sensitivity for bioanalytical quantification but requires specific Collision-Induced Dissociation (CID) energies to yield diagnostic fragments.

Mechanistic Fragmentation Analysis (EI)

In Electron Ionization (70 eV), the molecule forms a radical cation

at m/z 225. The fragmentation is governed by the interplay between the electron-withdrawing nitro group and the electron-donating methoxy groups, further complicated by steric "ortho effects."

Key Fragmentation Pathways[2]

- -Cleavage (Loss of Methyl/Acetyl):
 - The acetophenone core typically undergoes

-cleavage.
 - Path A: Loss of the methyl radical (

, 15 Da) from the acetyl group creates the acylium ion

.
 - Path B: Loss of the acetyl radical (

, 43 Da) yields the phenyl cation

.
- Nitro Group Elimination:
 - Loss of

(46 Da): A diagnostic cleavage for nitro-aromatics, typically yielding a peak at m/z 179.
 - Loss of NO (30 Da): Often observed if a rearrangement occurs prior to fragmentation, leading to a phenoxy-type ion.
- The "Ortho Effect" (Crucial for Isomer Specificity):
 - Acetyl vs. 2-Methoxy: The 2-methoxy group contains

-hydrogens relative to the acetyl carbonyl. This allows for a McLafferty-like rearrangement, potentially leading to the loss of formaldehyde (

, 30 Da) or an

radical transfer.

- 3-Nitro vs. 2-Methoxy: Steric crowding between the 2-OMe and 3- groups weakens the bond, enhancing the intensity of the fragment compared to isomers where these groups are para/meta.

Visualization of Fragmentation Pathways

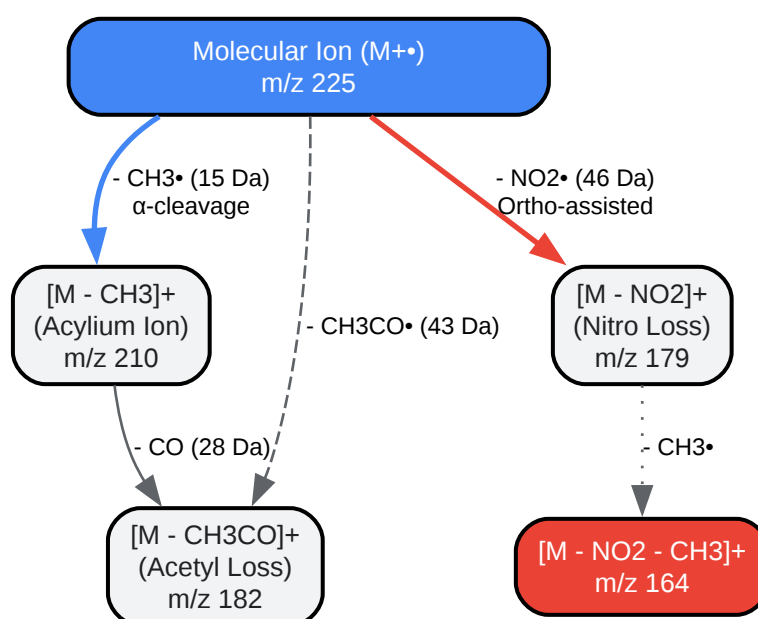

[Click to download full resolution via product page](#)

Figure 1: Primary EI fragmentation pathways for 3-Nitro-2,4-dimethoxyacetophenone. The competition between nitro loss and methyl/acetyl loss is the defining spectral characteristic.

Comparative Analysis: EI vs. ESI-MS/MS

This section compares the utility of Hard Ionization (EI) versus Soft Ionization (ESI) for this specific analyte.

Performance Matrix

Feature	Electron Ionization (EI)	Electrospray Ionization (ESI)
Ionization Mode	Hard (70 eV)	Soft (Positive/Negative Mode)
Primary Ion	(m/z 225) - often low intensity	(m/z 226) or (m/z 248)
Base Peak	Often m/z 210 () or 179 ()	m/z 226 (Intact Protonated Molecule)
Structural Data	Rich fragmentation without collision cell.	Requires CID (MS/MS) to generate fragments.
Sensitivity	Moderate (ng range)	High (pg range)
Matrix Tolerance	High (Gas Phase)	Low (Susceptible to Ion Suppression)
Best Application	Impurity identification, library matching.	PK studies, trace quantification in plasma.

ESI-MS/MS Specifics (CID Behavior)

In ESI (+), the protonated molecule

is stable. Upon Collision Induced Dissociation (CID):

- Water Loss: Rare for this structure (no -OH groups), unless nitro-rearrangement occurs.
- Methanol Loss: Loss of neutral (32 Da) is common from the methoxy groups, yielding m/z 194.
- Radical vs. Neutral Loss: Unlike EI, ESI prefers even-electron pathways. Direct loss of (radical) is less favored than loss of neutral (47 Da) or similar rearrangements.

Experimental Protocols

Workflow A: GC-MS (EI) for Impurity Profiling

Objective: Confirm structural identity via spectral library matching.

- Sample Preparation: Dissolve 1 mg of sample in 1 mL Dichloromethane (DCM).
- Inlet: Splitless injection at 250°C.
- Column: DB-5ms or equivalent (30m x 0.25mm, 0.25µm film).
- Oven Program:
 - Hold 60°C for 1 min.
 - Ramp 20°C/min to 300°C.
 - Hold 5 min.
- MS Source: 230°C, 70 eV. Scan range 40–400 amu.

Workflow B: LC-MS/MS (ESI) for Quantification

Objective: High-sensitivity detection in biological matrices.

- Mobile Phase:
 - A: 0.1% Formic Acid in Water.
 - B: 0.1% Formic Acid in Acetonitrile.
- Gradient: 5% B to 95% B over 5 minutes.
- Ion Source: ESI Positive Mode.
 - Capillary Voltage: 3.5 kV.
 - Desolvation Temp: 350°C.

- MRM Transitions (Quantification):
 - Precursor: 226.1 ()
 - Product 1: 179.0 (Loss of / - Quantifier)
 - Product 2: 194.1 (Loss of - Qualifier)

Workflow Logic Diagram

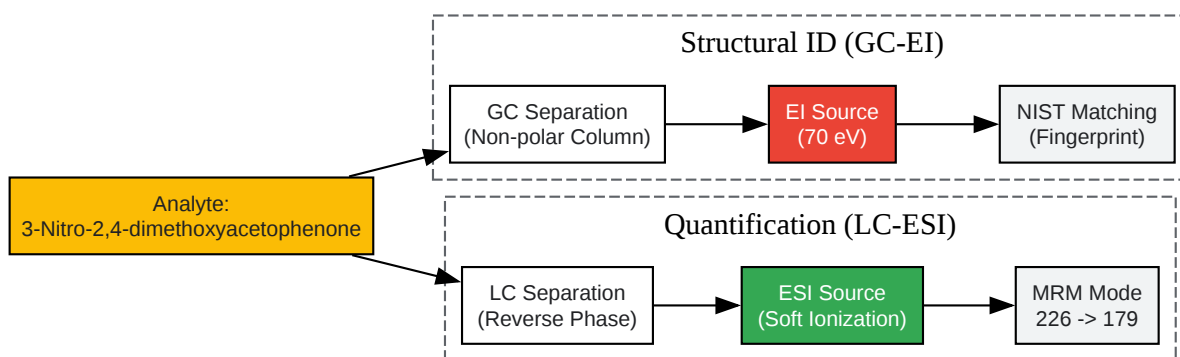

[Click to download full resolution via product page](#)

Figure 2: Decision workflow for selecting the appropriate ionization technique based on analytical goals (Identification vs. Quantification).

References

- McLafferty, F. W., & Tureček, F. (1993). Interpretation of Mass Spectra (4th ed.). University Science Books. (The foundational text for interpreting McLafferty rearrangements and ortho-effects).

- NIST Mass Spectrometry Data Center. (2026). NIST/EPA/NIH Mass Spectral Library. [[Link](#)]
- Holčapek, M., et al. (2010). "Basic rules for the interpretation of atmospheric pressure ionization mass spectra of small molecules." *Journal of Mass Spectrometry*, 45(9). [[Link](#)]
- Yinon, J. (1982). "Mass spectrometry of explosives: Nitro compounds." *Mass Spectrometry Reviews*, 1(1). (Authoritative source on nitro-group fragmentation). [[Link](#)]

Need Custom Synthesis?

BenchChem offers custom synthesis for rare earth carbides and specific isotopic labeling.

Email: info@benchchem.com or [Request Quote Online](#).

Sources

- [1. researchgate.net](https://www.researchgate.net) [[researchgate.net](https://www.researchgate.net)]
- To cite this document: BenchChem. [Technical Guide: Mass Spectrometry Fragmentation of 3-Nitro-2,4-dimethoxyacetophenone]. BenchChem, [2026]. [Online PDF]. Available at: [<https://www.benchchem.com/product/b11882633/docs#technical-guide-mass-spectrometry-fragmentation-of-3-nitro-2-4-dimethoxyacetophenone>]

Disclaimer & Data Validity:

The information provided in this document is for Research Use Only (RUO) and is strictly not intended for diagnostic or therapeutic procedures. While BenchChem strives to provide accurate protocols, we make no warranties, express or implied, regarding the fitness of this product for every specific experimental setup.

Technical Support: The protocols provided are for reference purposes. Unsure if this reagent suits your experiment?

Need Industrial/Bulk Grade? [Request Custom Synthesis Quote](#)

BenchChem

Our mission is to be the trusted global source of essential and advanced chemicals, empowering scientists and researchers to drive progress in science and industry.

Contact

Address: 3281 E Guasti Rd

Ontario, CA 91761, United States

Phone: (601) 213-4426

Email: info@benchchem.com

[Contact our Ph.D. Support Team for a compatibility check](#)