

# Technical Support Center: Navigating the Challenges in Trifluoromethylation

**Author:** BenchChem Technical Support Team. **Date:** April 2026

## Compound of Interest

Compound Name: 4-[2-(Trifluoromethyl)pyrrolidin-1-yl]aniline

CAS No.: 1395031-65-8

Cat. No.: B11879431

[Get Quote](#)

Welcome to the comprehensive support guide for researchers, scientists, and drug development professionals engaged in the synthesis of trifluoromethyl-containing compounds. The introduction of the trifluoromethyl (CF<sub>3</sub>) group is a transformative strategy in modern chemistry, capable of enhancing metabolic stability, lipophilicity, and the binding affinity of molecules.<sup>[1][2][3]</sup> However, the synthetic pathways to these valuable compounds are frequently paved with challenges, from reagent instability to unpredictable side reactions and purification difficulties.<sup>[3]</sup>

This guide is structured to provide practical, in-depth solutions to the common problems encountered in electrophilic, nucleophilic, and radical trifluoromethylation reactions. Here, you will find not just protocols, but the rationale behind them, empowering you to troubleshoot effectively and optimize your synthetic outcomes.

## Frequently Asked Questions (FAQs)

Q1: What are the primary categories of trifluoromethylation reactions?

A1: Trifluoromethylation reactions are broadly classified into three types based on the reactive nature of the trifluoromethylating agent:

- **Electrophilic Trifluoromethylation:** This involves a nucleophilic substrate reacting with an electrophilic "CF<sub>3</sub><sup>+</sup>" source. Key reagents in this category include hypervalent iodine compounds (e.g., Togni's reagents) and sulfonium salts (e.g., Umemoto's reagents).[4][5]
- **Nucleophilic Trifluoromethylation:** This method involves an electrophilic substrate reacting with a nucleophilic "CF<sub>3</sub><sup>-</sup>" source. The most prominent reagent is the Ruppert-Prakash reagent (TMSCF<sub>3</sub>).[4]
- **Radical Trifluoromethylation:** This approach utilizes a trifluoromethyl radical (CF<sub>3</sub>•) to react with the substrate. These radicals are typically generated from precursors like sodium trifluoromethanesulfinate (Langlois' reagent) or trifluoroiodomethane (CF<sub>3</sub>I) under oxidative or photoredox conditions.[4]

Q2: How do I choose the right trifluoromethylating reagent for my substrate?

A2: The choice of reagent is critical and depends on the substrate's electronic properties and the desired transformation.

- For electron-rich systems, such as activated methylene compounds (e.g., β-ketoesters), electrophilic reagents are generally preferred. Umemoto-type sulfonium salts often provide higher yields than Togni's hypervalent iodine reagents for these substrates.[1][5]
- For direct C-H functionalization of heterocycles, radical methods using the cost-effective and stable Langlois' reagent are a robust option.[1]
- For the trifluoromethylation of carbonyl compounds, the nucleophilic Ruppert-Prakash reagent is highly effective.[2]

Q3: My trifluoromethylated product seems to be unstable on silica gel. What are my purification options?

A3: The acidic nature of standard silica gel can lead to the degradation of sensitive compounds. Here are some alternative strategies:

- Deactivated Silica Gel: Prepare a slurry of silica gel with your eluent and add a small amount of a basic modifier like triethylamine (~0.5-1% by volume).
- Alternative Stationary Phases: Neutral alumina can be a good substitute for basic compounds.
- Reversed-Phase Chromatography: Using a C18-functionalized silica with polar mobile phases (e.g., acetonitrile/water) is another effective option.
- Recrystallization: If your compound is a solid with relatively high purity (>90%), recrystallization is often the most efficient method to achieve high purity.[6]

## Troubleshooting Guides

This section is dedicated to addressing specific issues you might encounter during your experiments.

### Category: Electrophilic Trifluoromethylation (e.g., using Togni or Umemoto Reagents)

Problem 1: Low to no conversion of my starting material, especially with electron-rich aromatic substrates.

This is a common issue that often points to insufficient activation of the trifluoromethylating reagent.

- Causality: Electrophilic trifluoromethylating reagents, particularly Togni's reagents, often require an activator to enhance their electrophilicity.[4]
- Troubleshooting Protocol:
  - Introduce a Lewis or Brønsted Acid: The addition of a catalytic amount of a strong acid can significantly boost the reagent's reactivity.
    - Lewis Acids: Zinc salts can be effective, particularly for O-trifluoromethylation.
    - Brønsted Acids: Strong acids like triflic acid have been shown to activate hypervalent iodine reagents.[4][5][7] For sulfonic acids, the Brønsted acidity of the substrate itself

can activate the reagent.[5]

- Optimize Reaction Conditions:
  - Temperature: While many reactions proceed at room temperature, some substrates may need elevated temperatures.
  - Solvent: Screen polar aprotic solvents like DMF or acetonitrile.[4]
- Check Reagent Integrity: Togni's reagents can be sensitive to moisture and light.[4]
  - Use a fresh batch of the reagent.
  - Ensure proper storage under anhydrous and dark conditions.
  - Conduct the reaction under an inert atmosphere (e.g., nitrogen or argon).

Problem 2: Poor selectivity between C- and O-trifluoromethylation of phenols.

The competing nucleophilicity of the oxygen atom and the aromatic ring in phenols can lead to a mixture of products.

- Causality: The reaction conditions, particularly the choice of base and solvent, play a critical role in directing the selectivity.
- Troubleshooting Protocol:
  - Base Selection: Using a strong base like sodium hydride (NaH) to fully deprotonate the phenol to the more nucleophilic phenoxide is a crucial first step.
  - Solvent Effects: A less coordinating solvent may favor O-trifluoromethylation. In contrast, coordinating solvents like DMF can promote C-trifluoromethylation.
  - Steric Hindrance: If possible, introduce bulky groups at the ortho-positions of the phenol to sterically block C-attack and favor O-trifluoromethylation.

## Category: Nucleophilic Trifluoromethylation (e.g., using Ruppert-Prakash Reagent - $\text{TMSCF}_3$ )

Problem 1: Sluggish reaction and low yields when trifluoromethylating an aldehyde or ketone.

This issue often stems from problems with the generation or stability of the trifluoromethyl anion ( $\text{CF}_3^-$ ).

- Causality: The Ruppert-Prakash reagent ( $\text{TMSCF}_3$ ) requires a nucleophilic initiator, typically a fluoride source, to generate the reactive trifluoromethyl anion. The presence of water can quench this anion.[4]
- Troubleshooting Protocol:
  - Ensure Anhydrous Conditions: Your fluoride source (e.g., TBAF, CsF) must be anhydrous. Water will protonate the trifluoromethyl anion, halting the reaction.
  - Increase Initiator Stoichiometry: In some cases, catalytic amounts of the fluoride initiator are insufficient. Try increasing to stoichiometric amounts.
  - Consider Alternative Initiation Systems: Some catalytic systems do not require an external fluoride source.

Problem 2: Formation of hydrodefluorination byproducts.

The loss of a fluorine atom from the trifluoromethyl group can sometimes occur.

- Causality: This can be promoted by certain reaction conditions or the presence of reducing agents.
- Troubleshooting Protocol:
  - Control Reaction Temperature: Lowering the reaction temperature can often suppress this side reaction.
  - Scrutinize Reagents: Ensure that no unintended reducing agents are present in your reaction mixture.
  - Modify Workup: A careful aqueous workup can help to remove species that might promote hydrodefluorination.

## Category: Radical Trifluoromethylation (e.g., using Langlois' Reagent)

Problem 1: Low yields and formation of dimerized side products in the trifluoromethylation of an alkene.

Dimerization suggests that the concentration of the trifluoromethyl radical is not optimized for the desired reaction pathway.

- Causality: A higher concentration of the  $\text{CF}_3$  radical can favor the reaction with the alkene over the dimerization of the substrate radical intermediate.
- Troubleshooting Protocol:
  - Increase Catalyst Concentration: For copper-catalyzed systems, increasing the amount of the copper catalyst can lead to a higher steady-state concentration of the trifluoromethyl radical.
  - Optimize Initiation: The method of radical initiation is crucial. For photoredox catalysis, ensure your light source is of the appropriate wavelength and intensity. For chemical initiation (e.g., with an oxidant like t-BuOOH), control the rate of addition.[1]
  - Solvent Choice: The solvent can influence the regioselectivity of radical addition. For instance, in the trifluoromethylation of 4-acetylpyridine, a switch from a dichloromethane/water system to a DMSO/water system can reverse the regioselectivity. [8]

Problem 2: Significant polymerization of conjugated olefins like styrene.

Styrenic substrates are prone to polymerization under radical conditions.

- Causality: The key is to ensure the rate of trifluoromethylation is significantly faster than the rate of polymerization.
- Troubleshooting Protocol:

- Temperature Control: Lowering the reaction temperature generally disfavors polymerization.[4]
- Slow Addition: The slow addition of the radical initiator or the trifluoromethylating reagent can maintain a low concentration of radical species, thereby minimizing polymerization.[4]

## Data & Reagent Comparison

For a more informed selection of your trifluoromethylating reagent, the following table provides a comparative overview of commonly used reagents.

Reagent Class	Common Examples	Primary Application	Key Advantages	Common Challenges
Electrophilic	Togni's Reagents, Umemoto's Reagents	Trifluoromethylation of nucleophiles (e.g., $\beta$ -ketoesters, indoles)	Broad functional group tolerance; commercially available.	May require activation (Lewis/Brønsted acids); reagent stability can be an issue; C- vs. O-selectivity challenges with phenols.[1][4][5]
Nucleophilic	Ruppert-Prakash Reagent (TMSCF <sub>3</sub> )	Trifluoromethylation of carbonyls and imines	Highly effective for carbonyl compounds.	Requires a nucleophilic initiator (e.g., fluoride); highly sensitive to moisture.[4]
Radical	Langlois' Reagent (CF <sub>3</sub> SO <sub>2</sub> Na), CF <sub>3</sub> I	C-H trifluoromethylation of heterocycles; trifluoromethylation of alkenes	Cost-effective and stable reagent; operationally simple protocols.	Potential for side reactions like dimerization and polymerization; regioselectivity can be an issue. [1][4]

## Experimental Protocols

### Protocol 1: General Procedure for Electrophilic Trifluoromethylation of a $\beta$ -Ketoester with an Umemoto Reagent

This protocol is representative for the trifluoromethylation of an activated methylene compound.

- **Preparation of the Enolate:** To a solution of the  $\beta$ -ketoester (1.0 equiv) in a suitable solvent (e.g., DMF), add a base (e.g., NaH, 1.1 equiv) at room temperature. Stir for 15-30 minutes.
- **Trifluoromethylation:** Cool the reaction mixture to the desired temperature (e.g., -20 °C to room temperature). Add the Umemoto reagent (1.0-1.2 equiv) portion-wise.
- **Reaction Monitoring:** Monitor the reaction progress by TLC or LC-MS.
- **Workup:** Upon completion, quench the reaction with a saturated aqueous solution of  $\text{NH}_4\text{Cl}$ . Extract the aqueous layer with an organic solvent (e.g., ethyl acetate).
- **Purification:** Wash the combined organic layers with brine, dry over anhydrous  $\text{Na}_2\text{SO}_4$ , and concentrate under reduced pressure. Purify the crude product by flash column chromatography.

### Protocol 2: General Procedure for Radical C-H Trifluoromethylation of a Heterocycle with Langlois' Reagent

This protocol is suitable for the direct functionalization of many heterocyclic systems.<sup>[1]</sup>

- **Reaction Setup:** To a solution of the heterocycle (1.0 equiv) in a solvent system (e.g.,  $\text{CH}_2\text{Cl}_2/\text{H}_2\text{O}$ ), add sodium trifluoromethanesulfinate (Langlois' reagent, 3.0 equiv).
- **Initiation:** Add an oxidant, such as tert-butyl hydroperoxide (t-BuOOH, 5.0 equiv).
- **Reaction:** Stir the mixture at ambient temperature for 3-24 hours. For less reactive substrates, a second addition of the Langlois' reagent and oxidant may be necessary.<sup>[1]</sup>
- **Workup and Purification:** Upon completion, perform a standard aqueous workup and extract with an organic solvent. Purify the product by column chromatography.

## Visualizing Reaction Pathways

The following diagrams illustrate key concepts in trifluoromethylation.

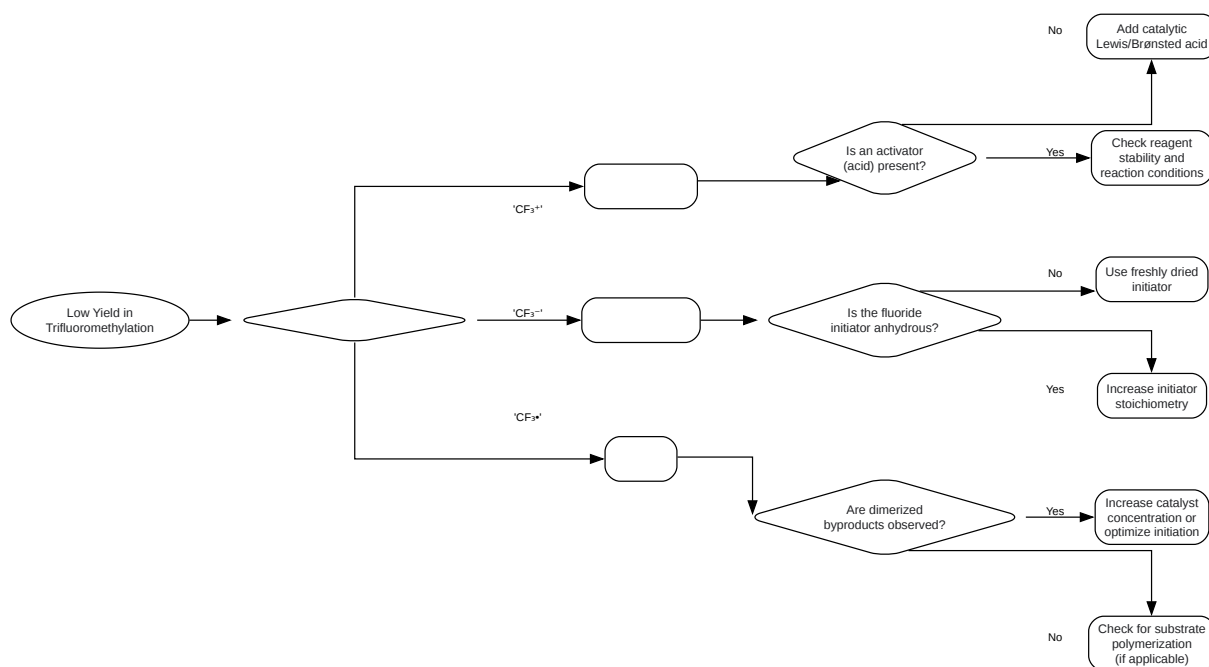

[Click to download full resolution via product page](#)

Caption: A troubleshooting decision tree for low-yield trifluoromethylation reactions.

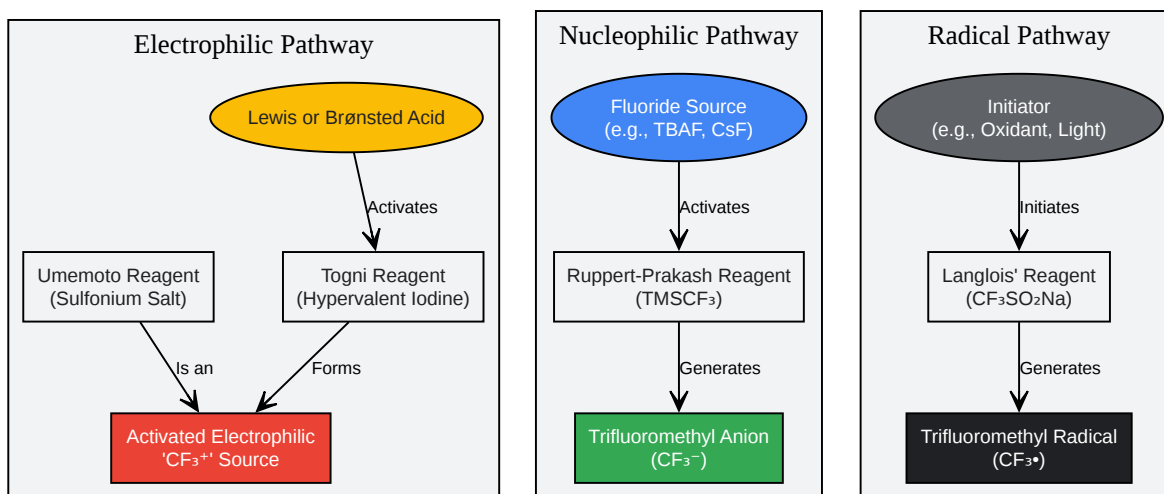

[Click to download full resolution via product page](#)

Caption: Activation pathways for different classes of trifluoromethylating reagents.

## References

- Shibata, N., Matsnev, A., & Cahard, D. (2010). Shelf-stable electrophilic trifluoromethylating reagents: A brief historical perspective. *Beilstein Journal of Organic Chemistry*, 6, 65. Available at: [\[Link\]](#)
- MacMillan, D. W. C., et al. (2011). Innate C-H trifluoromethylation of heterocycles. *Proceedings of the National Academy of Sciences*, 108(51), 20614-20619. Available at: [\[Link\]](#)
- Baran, P. S., et al. (2011). Innate C-H trifluoromethylation of heterocycles. *Proceedings of the National Academy of Sciences*, 108(35), 14411-14415.
- Qing, F.-L., et al. (2009). Brønsted Acid Mediated ( $\text{sp}^3$ )Carbon-Fluorine Bond Activation: Inter- and Intramolecular Arylation of Trifluoromethylated Arenes. *Chinese Journal of Chemistry*, 27(8), 1573-1578.

- Langlois, B. R., et al. (2017). CF<sub>3</sub>SO<sub>2</sub>X (X = Na, Cl) as reagents for trifluoromethylation, trifluoromethylsulfenyl-, -sulfinyl- and -sulfonylation. Part 1: Use of CF<sub>3</sub>SO<sub>2</sub>Na. *Beilstein Journal of Organic Chemistry*, 13, 2856-2901. Available at: [\[Link\]](#)
- SigutLabs. (2022). Reagent of the month – November - Langlois reagent. Available at: [\[Link\]](#)
- Beller, M., et al. (2018). Progress in copper-catalyzed trifluoromethylation.
- Togni, A. (2014). Electrophilic Trifluoromethylation by Use of Hypervalent Iodine Reagents.
- Mayr, H., et al. (2014). Cation versus Radical: Studies on the C/O Regioselectivity in Electrophilic Tri-, Di- and Monofluoromethylations of β-Ketoesters. *Chemistry – A European Journal*, 20(43), 14075-14084.
- Ley, S. V., et al. (2017). Real-Time Spectroscopic Analysis Enabling Quantitative and Safe Consumption of Fluoroform during Nucleophilic Trifluoromethylation in Flow. *Organic Letters*, 19(24), 6638-6641.
- Wang, J., et al. (2021). Recent advances in the application of Langlois' reagent in olefin difunctionalization. *Organic & Biomolecular Chemistry*, 19(4), 735-746.
- Gouverneur, V., et al. (2020). Quantification of the Activation Capabilities of Lewis/Brønsted Acid for Electrophilic Trifluoromethylthiolating Reagents. *The Journal of Organic Chemistry*, 85(15), 9684-9693.
- Sodeoka, M., et al. (2019). Regioselective C–H Trifluoromethylation of Aromatic Compounds by Inclusion in Cyclodextrins. *Organic Letters*, 21(16), 6439-6443.
- Beller, M., et al. (2012). Copper-catalyzed trifluoromethylation of aryl- and vinylboronic acids with generation of CF<sub>3</sub>-radicals.
- Bayer AG. (1981). Process for the preparation of 2-trifluoromethyl aniline.
- Qing, F.-L., et al. (2012). Copper-Catalyzed Oxidative Trifluoromethylation of Terminal Alkynes and Aryl Boronic Acids Using (Trifluoromethyl)trimethylsilane. *The Journal of Organic Chemistry*, 77(2), 1251-1257.
- Galić, N., et al. (2017). Rapid Identification of Unknown Impurities in 3-Bromo-5-(trifluoromethyl)aniline by LC-SPE/NMR.
- Togni, A., et al. (2016). Protocol for the Synthesis of Ortho-trifluoromethoxylated Aniline Derivatives. *Journal of Visualized Experiments*, (107), e53569.
- Sanford, M. S., et al. (2013). Practical Method for the Cu-Mediated Trifluoromethylation of Arylboronic Acids with CF<sub>3</sub> Radicals Derived from NaSO<sub>2</sub>CF<sub>3</sub> and tert-Butyl Hydroperoxide (TBHP). *Organic Letters*, 15(1), 10-13.
- Qing, F.-L., et al. (2019). Zinc–Brønsted acid mediated practical hydrotrifluoromethylation of alkenes with CF<sub>3</sub>Br. *Organic Chemistry Frontiers*, 6(16), 2899-2903.

- Mulder, J., et al. (2013). Industrial-scale trifluoromethylation challenges. Organic Chemistry Portal. Available at: [[Link](#)]
- Baran, P. S., et al. (2012). Radical trifluoromethylation using the Umemoto's reagents and Togni's reagents.
- Liu, G., et al. (2011). Copper-catalyzed trifluoromethylation of aryl boronic acids using a CF<sub>3</sub><sup>+</sup> reagent.
- Zhang, C. (2014). Recent advances in trifluoromethylation of organic compounds using Umemoto's reagents. Organic & Biomolecular Chemistry, 12(35), 6580-6589.
- Francis, M. B., et al. (2018). Selective Radical Trifluoromethylation of Native Residues in Proteins. Journal of the American Chemical Society, 140(2), 799-805.
- Pomerantz, W. C., et al. (2013). A comparison of chemical shift sensitivity of trifluoromethyl tags: optimizing resolution in <sup>19</sup>F NMR studies of proteins. Journal of Biomolecular NMR, 56(4), 323-334.
- Lu, L., et al. (2022). Application of Langlois' reagent (NaSO<sub>2</sub>CF<sub>3</sub>) in C–H functionalisation. Organic & Biomolecular Chemistry, 20(11), 2143-2154.
- Mayr, H., et al. (2019). Reactivity of Electrophilic Trifluoromethylating Reagents. Chemistry – A European Journal, 25(52), 12098-12111.
- Roy, D., et al. (2022). Solvent Effects in the Regioselective N-Functionalization of Tautomerizable Heterocycles Catalyzed by Methyl Trifluoromethanesulfonate: A Density Functional Theory Study with Implicit Solvent Model. Molecules, 27(19), 6439.
- Wikipedia. (n.d.). Trifluoromethylation. Retrieved from [[Link](#)]
- Stephenson, C. R. J., et al. (2015). A scalable and operationally simple radical trifluoromethylation.
- Liu, G., et al. (2015). Trifluoromethylation of Alkyl Radicals: Breakthrough and Challenges.
- Scaiano, J. C., et al. (2014). Metal-Free Photocatalytic Radical Trifluoromethylation Utilizing Methylene Blue and Visible Light Irradiation.
- MacMillan, D. W. C., et al. (2009). Enantioselective  $\alpha$ -Trifluoromethylation of Aldehydes via Photoredox Organocatalysis. Journal of the American Chemical Society, 131(30), 10810-10811.

### Need Custom Synthesis?

BenchChem offers custom synthesis for rare earth carbides and specific isotopic labeling.

Email: [info@benchchem.com](mailto:info@benchchem.com) or [Request Quote Online](#).

## Sources

- [1. pdf.benchchem.com \[pdf.benchchem.com\]](https://pdf.benchchem.com)
- [2. pdf.benchchem.com \[pdf.benchchem.com\]](https://pdf.benchchem.com)
- [3. kmt.vander-lingen.nl \[kmt.vander-lingen.nl\]](https://kmt.vander-lingen.nl)
- [4. pdf.benchchem.com \[pdf.benchchem.com\]](https://pdf.benchchem.com)
- [5. BJOC - Shelf-stable electrophilic trifluoromethylating reagents: A brief historical perspective \[beilstein-journals.org\]](https://beilstein-journals.org)
- [6. pdf.benchchem.com \[pdf.benchchem.com\]](https://pdf.benchchem.com)
- [7. pubs.acs.org \[pubs.acs.org\]](https://pubs.acs.org)
- [8. researchgate.net \[researchgate.net\]](https://researchgate.net)
- To cite this document: BenchChem. [Technical Support Center: Navigating the Challenges in Trifluoromethylation]. BenchChem, [2026]. [Online PDF]. Available at: [\[https://www.benchchem.com/product/b11879431/docs#technical-support-center-navigating-the-challenges-in-trifluoromethylation\]](https://www.benchchem.com/product/b11879431/docs#technical-support-center-navigating-the-challenges-in-trifluoromethylation)

---

### Disclaimer & Data Validity:

The information provided in this document is for Research Use Only (RUO) and is strictly not intended for diagnostic or therapeutic procedures. While BenchChem strives to provide accurate protocols, we make no warranties, express or implied, regarding the fitness of this product for every specific experimental setup.

**Technical Support:** The protocols provided are for reference purposes. Unsure if this reagent suits your experiment?

**Need Industrial/Bulk Grade?** [Request Custom Synthesis Quote](#)

# BenchChem

Our mission is to be the trusted global source of essential and advanced chemicals, empowering scientists and researchers to drive progress in science and industry.

## Contact

Address: 3281 E Guasti Rd

Ontario, CA 91761, United States

Phone: (601) 213-4426

Email: [info@benchchem.com](mailto:info@benchchem.com)

[Contact our Ph.D. Support Team for a compatibility check](#)