

Application Notes & Protocols: Synthesis of Hole Transport Materials

Author: BenchChem Technical Support Team. **Date:** April 2026

Compound of Interest

Compound Name: Silane, (4-bromophenyl)methoxydimethyl-

CAS No.: 17021-92-0

Cat. No.: B11866523

[Get Quote](#)

Introduction: The Critical Role of Hole Transport Materials in Modern Electronics

Hole Transport Materials (HTMs) are a cornerstone of high-performance organic and hybrid optoelectronic devices, including Perovskite Solar Cells (PSCs) and Organic Light-Emitting Diodes (OLEDs). Their primary function is to efficiently extract and transport positive charge carriers (holes) from the active layer (e.g., the perovskite absorber) to the anode, while simultaneously blocking electrons to prevent charge recombination losses.[1][2] The properties of the HTM profoundly influence overall device efficiency, stability, and longevity.[3]

An ideal HTM should possess a specific set of characteristics:

- **Appropriate Energy Levels:** The Highest Occupied Molecular Orbital (HOMO) energy level must be well-aligned with the valence band of the perovskite or the emissive layer to ensure efficient hole injection with minimal energy loss.[4][5]

- **High Hole Mobility:** Rapid charge transport (ideally $>10^{-3} \text{ cm}^2 \text{ V}^{-1} \text{ s}^{-1}$) is essential to minimize charge buildup and recombination at the interface.[4][6]
- **Optical Transparency:** The material should be transparent in the visible spectrum to avoid parasitic absorption and allow maximum light to reach the active layer.[4]
- **Thermal and Morphological Stability:** A high glass transition temperature (T_g) and the ability to form uniform, pinhole-free amorphous films are crucial for device durability and to prevent crystallization.[4][6]
- **Hydrophobicity:** In PSCs, a hydrophobic HTM can act as a barrier, protecting the sensitive perovskite layer from degradation by moisture.[3]

For years, 2,2',7,7'-tetrakis(N,N-di-p-methoxyphenylamine)-9,9'-spirobifluorene, widely known as Spiro-OMeTAD, has been the benchmark HTM, particularly in high-efficiency PSCs.[7][8] However, its widespread commercial application is hampered by a complex, multi-step synthesis, high purification costs, and mediocre intrinsic hole mobility that necessitates the use of performance-enhancing, yet stability-compromising, additives like Li-TFSI and tBP.[4][8][9] This has spurred intensive research into the design and synthesis of novel, cost-effective, and stable HTMs.

This guide provides an in-depth overview of the key synthetic strategies employed in the production of state-of-the-art HTMs, followed by a detailed, field-proven protocol for an efficient and sustainable synthesis of the benchmark material, Spiro-OMeTAD.

Core Synthetic Strategies for HTM Development

The molecular architecture of most organic HTMs is centered around an electron-rich core, often featuring triarylamine moieties. The synthesis of these complex molecules relies heavily on modern organometallic cross-coupling reactions, which allow for the precise and efficient formation of carbon-nitrogen (C-N) and carbon-carbon (C-C) bonds.

Buchwald-Hartwig Amination: The Workhorse of C-N Bond Formation

The Palladium-catalyzed Buchwald-Hartwig amination is arguably the most vital reaction in the HTM synthesis toolbox. It enables the coupling of an aryl halide (or triflate) with an amine, the

fundamental bond-forming step for creating the triarylamine structures that are ubiquitous in high-performance HTMs.^{[6][10]}

Causality of the Reaction: The reaction's efficacy stems from a Palladium catalyst that cycles between Pd(0) and Pd(II) oxidation states. A crucial component is the choice of a bulky, electron-rich phosphine ligand (e.g., XPhos, tBuXPhos), which stabilizes the palladium center, promotes the key steps of oxidative addition and reductive elimination, and prevents catalyst deactivation.^{[11][12]} A base is required to deprotonate the amine, making it a more active nucleophile for the coupling process.

Below is a diagram illustrating the catalytic cycle.

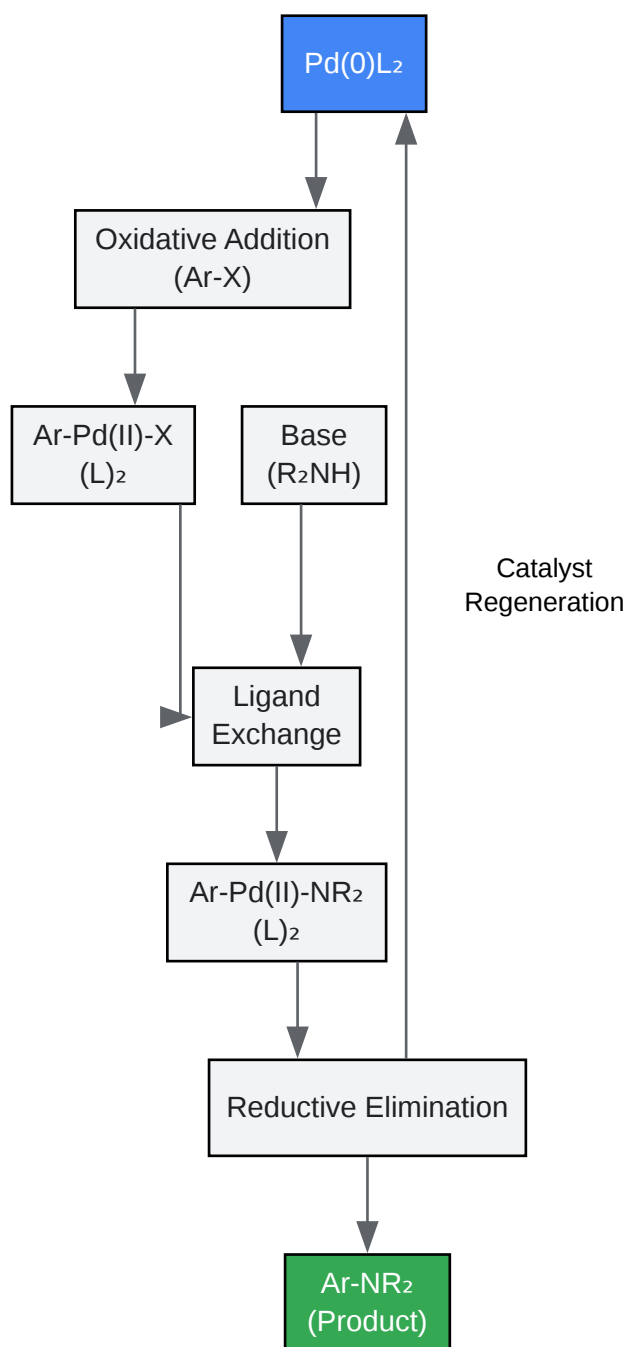

[Click to download full resolution via product page](#)

Caption: Catalytic cycle of the Buchwald-Hartwig amination.

Suzuki-Miyaura Coupling: Forging the Carbon Skeleton

The Suzuki-Miyaura coupling is another indispensable palladium-catalyzed reaction, used for forming C-C bonds between an organoboron species (like a boronic acid or ester) and an aryl

halide or triflate.^{[13][14]} This reaction is frequently used to synthesize the core structures of HTMs (e.g., fluorene or carbazole backbones) or to extend the π -conjugation of the molecule, which can tune its electronic properties.^{[15][16]}

Causality of the Reaction: The Suzuki reaction's success relies on a three-step catalytic cycle: oxidative addition of the aryl halide to the Pd(0) catalyst, transmetalation where the organic group from the boron reagent is transferred to the palladium center, and reductive elimination to form the new C-C bond and regenerate the catalyst.^{[14][17]} A base is essential for activating the organoboron compound, facilitating the transmetalation step.^[13]

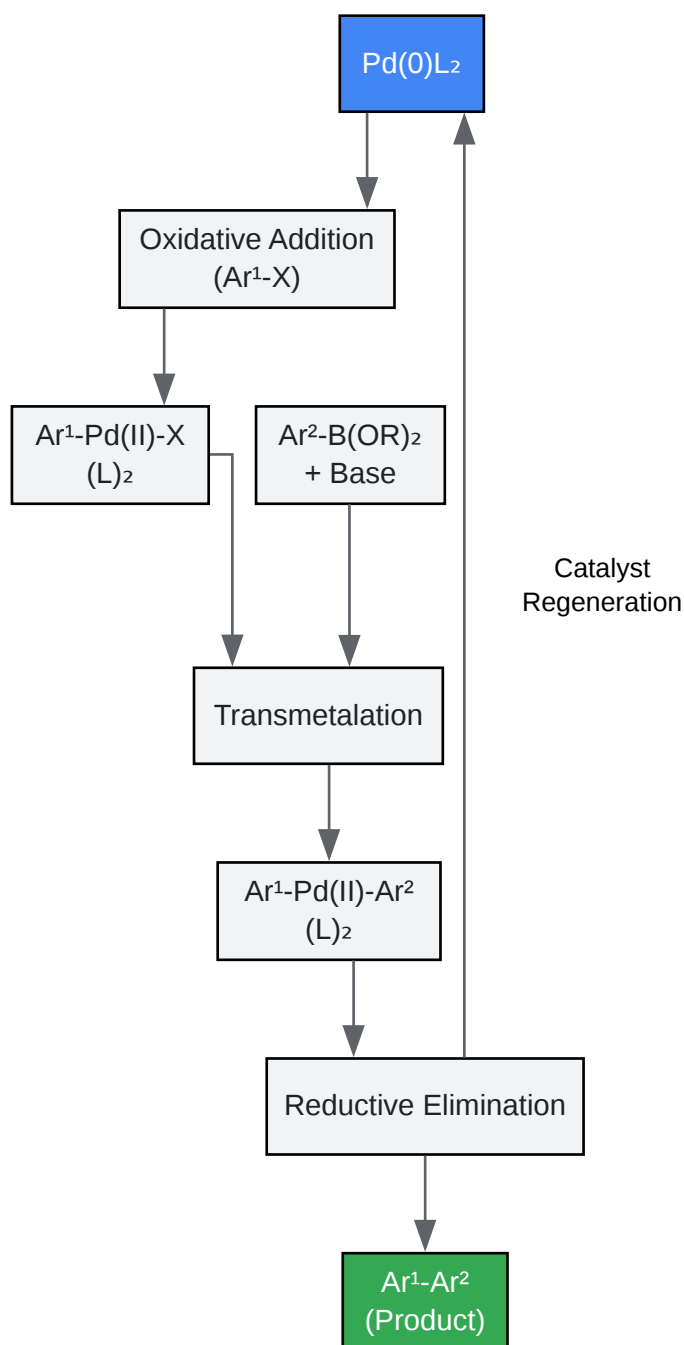

[Click to download full resolution via product page](#)

Caption: Catalytic cycle of the Suzuki-Miyaura cross-coupling.

Ullmann Condensation: A Classic Route

The Ullmann condensation is a classic copper-catalyzed reaction for forming C-N, C-O, and C-S bonds.[18][19][20] While largely superseded by the milder and more versatile palladium-

catalyzed methods for many applications, it remains relevant, especially in industrial-scale synthesis. The reaction typically involves coupling an aryl halide with an alcohol, amine, or thiol.

Causality of the Reaction: Traditional Ullmann reactions are notorious for requiring harsh conditions, such as high temperatures (often >200 °C) and polar, high-boiling solvents.[20] The mechanism involves the in-situ formation of a copper(I) species which then reacts with the aryl halide.[19] Modern advancements have introduced soluble copper catalysts with ligands (like 1,10-phenanthroline) that can significantly lower the required reaction temperature.[21]

Application Protocol: Sustainable Synthesis of Spiro-OMeTAD

This section details a green, efficient, and scalable protocol for the synthesis of Spiro-OMeTAD, adapted from advanced synthetic methodologies that minimize hazardous waste and improve overall efficiency.[22][23] The protocol avoids pyrophoric reagents and halogenated solvents, making it safer and more environmentally friendly than traditional routes.

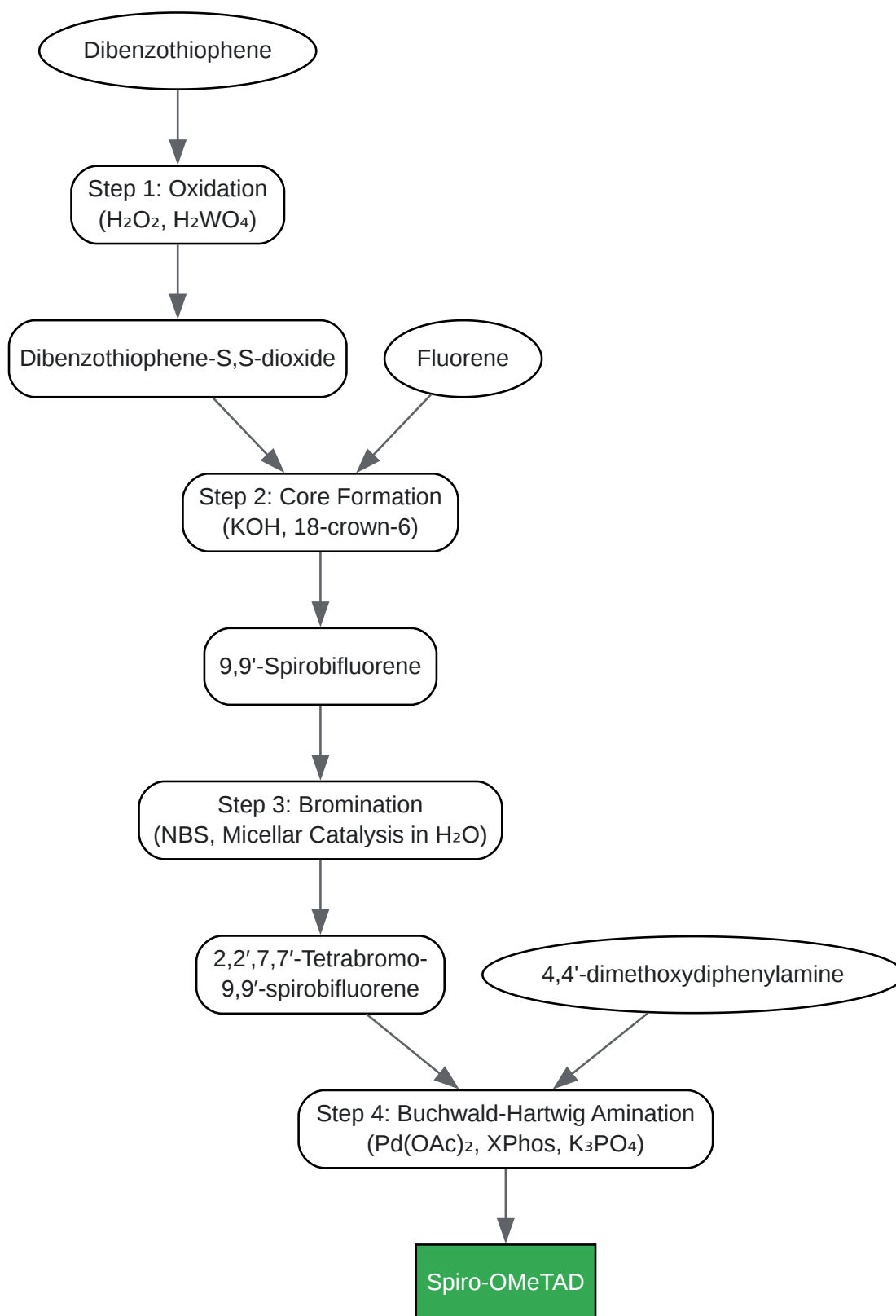

[Click to download full resolution via product page](#)

Need Custom Synthesis?

BenchChem offers custom synthesis for rare earth carbides and specific isotopic labeling.

Email: info@benchchem.com or [Request Quote Online](#).

Sources

- 1. [mdpi.com](https://www.mdpi.com) [[mdpi.com](https://www.mdpi.com)]
- 2. Data-Driven Analysis of Hole-Transporting Materials for Perovskite Solar Cells Performance - PMC [[pmc.ncbi.nlm.nih.gov](https://pubmed.ncbi.nlm.nih.gov/)]
- 3. Hole transport layer selection for stable and efficient carbon electrode-based perovskite solar cells - RSC Advances (RSC Publishing) DOI:10.1039/D5RA01694K [pubs.rsc.org]
- 4. Hole-Transporting Materials for Printable Perovskite Solar Cells - PMC [[pmc.ncbi.nlm.nih.gov](https://pubmed.ncbi.nlm.nih.gov/)]
- 5. pubs.acs.org [pubs.acs.org]
- 6. An efficient Buchwald–Hartwig amination protocol enables the synthesis of new branched and polymeric hole transport materials for perovskite solar cel ... - Energy Advances (RSC Publishing) DOI:10.1039/D2YA00135G [pubs.rsc.org]
- 7. trepo.tuni.fi [trepo.tuni.fi]
- 8. Unlocking the full potential of spiro-OMeTAD in perovskite solar cells: towards synthetic routes, doping mechanism, degradation, and stability - Journal of Materials Chemistry C (RSC Publishing) [pubs.rsc.org]
- 9. Unlocking the full potential of spiro-OMeTAD in perovskite solar cells: towards synthetic routes, doping mechanism, degradation, and stability - Journal of Materials Chemistry C (RSC Publishing) [pubs.rsc.org]
- 10. [researchgate.net](https://www.researchgate.net) [[researchgate.net](https://www.researchgate.net)]
- 11. pubs.acs.org [pubs.acs.org]
- 12. hammer.purdue.edu [hammer.purdue.edu]
- 13. Suzuki Coupling [[organic-chemistry.org](https://www.organic-chemistry.org)]
- 14. [youtube.com](https://www.youtube.com) [[youtube.com](https://www.youtube.com)]
- 15. [researchgate.net](https://www.researchgate.net) [[researchgate.net](https://www.researchgate.net)]
- 16. [researchgate.net](https://www.researchgate.net) [[researchgate.net](https://www.researchgate.net)]

- [17. pubs.rsc.org \[pubs.rsc.org\]](https://pubs.rsc.org)
- [18. discovery.researcher.life \[discovery.researcher.life\]](https://discovery.researcher.life)
- [19. Ullmann Reaction \[organic-chemistry.org\]](https://organic-chemistry.org)
- [20. Ullmann condensation - Wikipedia \[en.wikipedia.org\]](https://en.wikipedia.org)
- [21. scispace.com \[scispace.com\]](https://scispace.com)
- [22. pubs.acs.org \[pubs.acs.org\]](https://pubs.acs.org)
- [23. boa.unimib.it \[boa.unimib.it\]](https://boa.unimib.it)
- To cite this document: BenchChem. [Application Notes & Protocols: Synthesis of Hole Transport Materials]. BenchChem, [2026]. [Online PDF]. Available at: [\[https://www.benchchem.com/product/b11866523/docs#application-notes-protocols-synthesis-of-hole-transport-materials\]](https://www.benchchem.com/product/b11866523/docs#application-notes-protocols-synthesis-of-hole-transport-materials)

Disclaimer & Data Validity:

The information provided in this document is for Research Use Only (RUO) and is strictly not intended for diagnostic or therapeutic procedures. While BenchChem strives to provide accurate protocols, we make no warranties, express or implied, regarding the fitness of this product for every specific experimental setup.

Technical Support: The protocols provided are for reference purposes. Unsure if this reagent suits your experiment?

Need Industrial/Bulk Grade? [Request Custom Synthesis Quote](#)

BenchChem

Our mission is to be the trusted global source of essential and advanced chemicals, empowering scientists and researchers to drive progress in science and industry.

Contact

Address: 3281 E Guasti Rd

Ontario, CA 91761, United States

Phone: (601) 213-4426

Email: info@benchchem.com

Contact our Ph.D. Support Team for a compatibility check