

# Technical Guide: Discovery and Synthesis of Halogenated Quinoline Compounds

**Author:** BenchChem Technical Support Team. **Date:** February 2026

## Compound of Interest

Compound Name: *2-Chloro-6-(chloromethyl)quinoline hydrochloride*  
Cat. No.: *B11865991*

[Get Quote](#)

## Strategic Overview: The Halogen Advantage in Quinoline Scaffolds

In modern medicinal chemistry, the quinoline core is a "privileged structure," serving as the backbone for antimalarials (Chloroquine), broad-spectrum antibiotics (Ciprofloxacin), and emerging kinase inhibitors (Lenvatinib). However, the naked quinoline ring is rarely the final drug. The strategic introduction of halogen atoms (F, Cl, Br, I) is the critical differentiator that transforms this heterocycle into a bioactive therapeutic.

### Why Halogenate?

- **Metabolic Blocking:** Halogens at the C2 or C4 positions block oxidative metabolism (e.g., preventing P450-mediated oxidation), significantly extending half-life ( ).
- **Lipophilicity Modulation:** Introducing chlorine or bromine increases , facilitating membrane permeability and blood-brain barrier (BBB) penetration.
- **Halogen Bonding:** Unlike hydrogen bonds, heavy halogens (Cl, Br, I) possess a "sigma-hole"—a region of positive electrostatic potential opposite the C-X bond—that allows for

specific, high-affinity interactions with carbonyl oxygens or aromatic systems in the target protein binding pocket.

## Decision Framework: De Novo Assembly vs. Late-Stage Functionalization

The synthesis of halogenated quinolines requires a bifurcation in strategy based on the desired substitution pattern.

- Route A: De Novo Construction (Ring Closure)
  - Best for: 4-substituted, 2-substituted, or polysubstituted quinolines where the halogen is on the benzene ring (positions 5, 6, 7, 8).
  - Classic Method:[\[1\]](#) Gould-Jacobs Reaction.[\[2\]](#)[\[3\]](#)[\[4\]](#)
- Route B: Late-Stage Functionalization (C-H Activation/Substitution)
  - Best for: Introducing halogens onto a pre-formed quinoline core, particularly at "difficult" positions (C3, C5, C8) or for diversifying a lead compound library.
  - Modern Method: Directed C-H Activation or Metal-Free Regioselective Halogenation.

## Visualization: Synthetic Decision Matrix

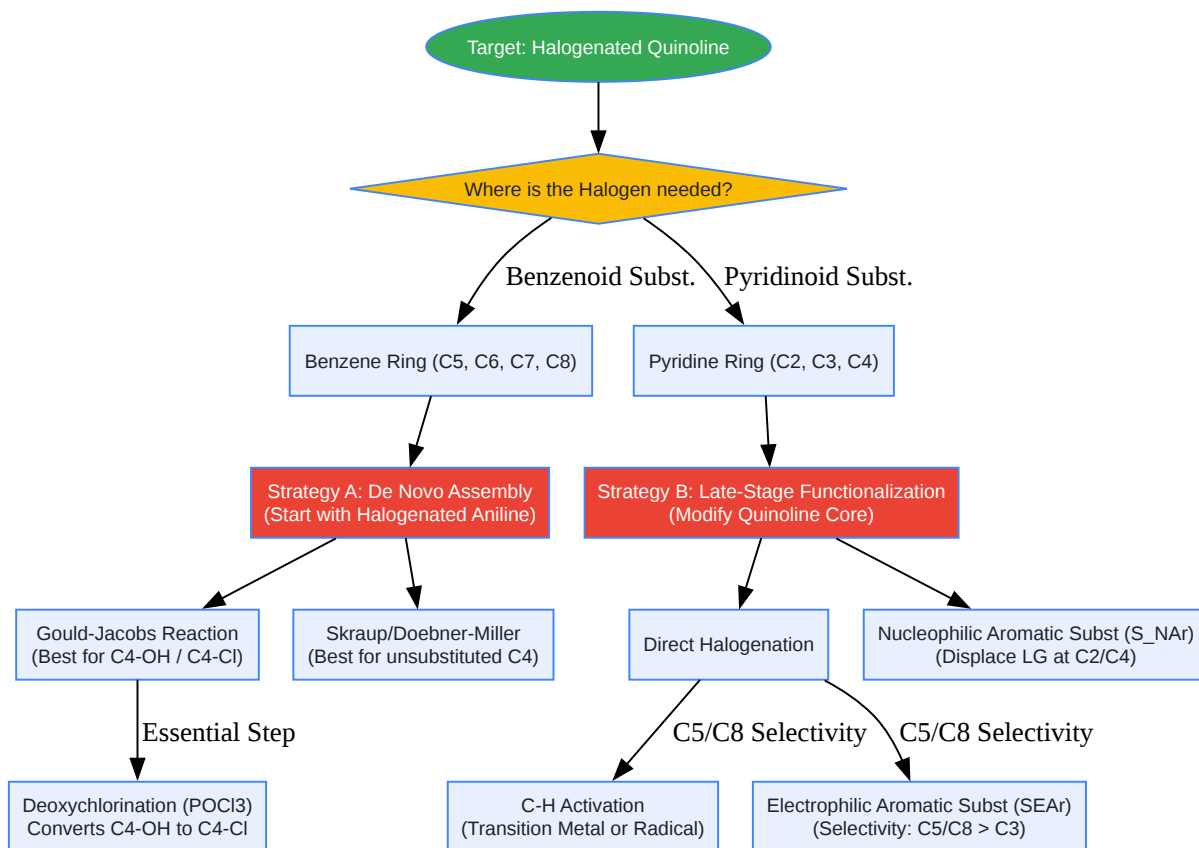

[Click to download full resolution via product page](#)

Figure 1: Strategic decision tree for selecting the optimal synthetic pathway based on regiochemical requirements.

## Protocol A: The "Classic" Industrial Standard Synthesis of 4,7-Dichloroquinoline (Chloroquine Precursor)

This protocol utilizes the Gould-Jacobs reaction, the industry standard for generating 4-hydroxyquinolines which are subsequently aromatized to 4-chloroquinolines. This route is

preferred for its scalability and the availability of cheap starting materials (

-chloroaniline).

Mechanism & Rationale:

- Condensation: Aniline reacts with EMME (diethyl ethoxymethylenemalonate).<sup>[2]</sup><sup>[4]</sup>
- Cyclization: Thermal electrocyclization ( ) forms the pyridine ring.<sup>[4]</sup> The high temperature is necessary to overcome the aromatic stability of the benzene ring during the transition state.
- Aromatization: The resulting 4-hydroxyquinoline is actually a 4-quinolone tautomer. Treatment with phosphorus oxychloride ( ) converts the C=O into a C-Cl bond via an imidoyl chloride intermediate, restoring full aromaticity to the pyridine ring and creating a reactive handle for further functionalization ( ).

## Experimental Workflow

Reagents:

- -Chloroaniline (1.0 eq)
- Diethyl ethoxymethylenemalonate (EMME) (1.1 eq)
- Diphenyl ether (Dowtherm A) (Solvent for high T)
- Sodium Hydroxide (NaOH)<sup>[4]</sup>
- Phosphorus Oxychloride ( )

Step-by-Step Protocol:

- Enamine Formation:

- Charge a reactor with
  - chloroaniline (127.6 g, 1.0 mol) and EMME (237.8 g, 1.1 mol).
- Heat to
  - for 2 hours under vacuum or with a distillation head to remove the ethanol byproduct. This drives the equilibrium forward.
- Checkpoint: The mixture solidifies upon cooling (Enamine intermediate).
- Thermal Cyclization (Gould-Jacobs):
  - Add the enamine to boiling Diphenyl ether (
    - ).). Caution: Exothermic cyclization.
  - Maintain reflux for 1-2 hours.[2][4]
  - Cool to room temperature.[5] The ester intermediate (ethyl 7-chloro-4-hydroxyquinoline-3-carboxylate) will precipitate. Filter and wash with hexane.
- Hydrolysis & Decarboxylation:
  - Reflux the ester in 10% NaOH solution for 3 hours (Saponification).
  - Acidify with HCl to precipitate the carboxylic acid.[4]
  - Heat the dry acid in Dowtherm A at
    - until
    - evolution ceases. This yields 7-chloro-4-hydroxyquinoline.[6]
- Deoxychlorination:
  - Suspend the 7-chloro-4-hydroxyquinoline in toluene.
  - Add

(1.5 eq) dropwise at

.

- Reflux for 2 hours.[4] The solution will clarify as the starting material is consumed.
- Quench: Pour onto crushed ice/ammonia water (exothermic!).
- Extract with dichloromethane (DCM), dry over  
  
, and concentrate.
- Yield: ~80-85% of 4,7-dichloroquinoline.

## Protocol B: Modern Late-Stage Functionalization Metal-Free Regioselective C5-Halogenation

While the Gould-Jacobs route builds the ring, modern drug discovery often requires modifying an existing quinoline scaffold. The C5 position is notoriously difficult to access via standard electrophilic aromatic substitution (EAS) due to the competing protonation of the nitrogen, which deactivates the ring.

The following protocol uses Trihaloisocyanuric Acids (TCCA/TBCA) to achieve exclusive C5 regioselectivity under mild conditions, avoiding toxic transition metals.

Mechanism: The reaction proceeds via a radical pathway or a highly polarized complex where the amide/amine substituent at C8 (if present) or the inherent electronics of the quinoline directs the halogen to the C5 position (the most electron-rich position on the carbocycle).

### Experimental Workflow

Reagents:

- 8-Substituted Quinoline substrate (e.g., 8-methoxyquinoline or 8-aminoquinoline)
- Trichloroisocyanuric acid (TCCA) or Tribromoisocyanuric acid (TBCA) (0.34 eq - note: each mole provides 3 halogen atoms)
- Solvent: Acetonitrile (

) or Water (

)

Step-by-Step Protocol:

- Preparation:
  - Dissolve the quinoline substrate (1.0 mmol) in (5 mL).
- Addition:
  - Add TCCA (0.34 mmol) or TBCA (0.34 mmol) in one portion.
- Reaction:
  - Stir at room temperature (RT) for 1-4 hours.
  - Monitoring: Check TLC for the disappearance of the starting material. The reaction is typically very fast.
- Workup:
  - Filter off the cyanuric acid byproduct (white solid).
  - Concentrate the filtrate.
  - Purify via silica gel flash chromatography (Hexane/EtOAc).
- Result:
  - Yields are typically >90% with >95:5 regioselectivity for the 5-haloquinoline.<sup>[7]</sup>

## Visualization: Regioselectivity & Mechanism<sup>[7]</sup><sup>[8]</sup>

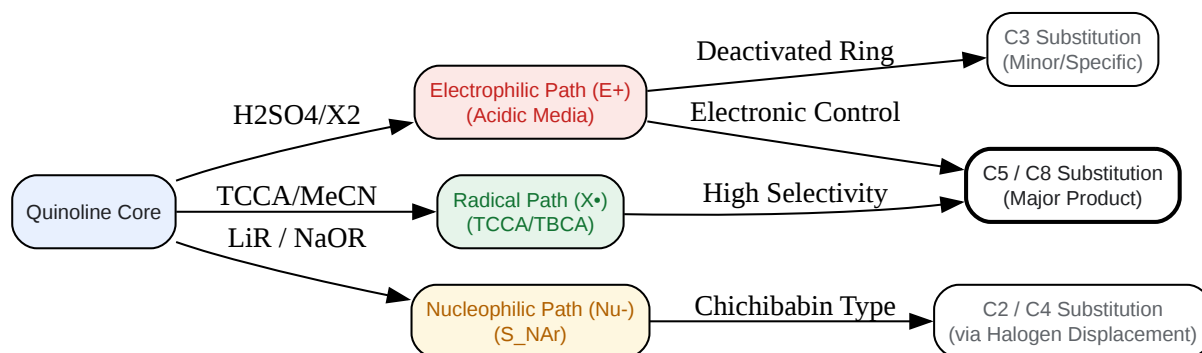

[Click to download full resolution via product page](#)

Figure 2: Mechanistic map showing how reaction conditions dictate regioselectivity on the quinoline scaffold.

## Structure-Activity Relationship (SAR) Data

When designing halogenated quinolines, the choice of halogen impacts physicochemical properties. The table below summarizes the effects of substituting a Hydrogen (H) with a Halogen at the C7 position (relevant to chloroquine analogs).

Substituent (C7)	(Hammett)	(Lipophilicity)	Metabolic Stability	Primary Effect
-H	0.00	2.50	Low	Baseline
-F	0.06	2.65	High	Blocks metabolic oxidation; minimal steric clash.
-Cl	0.23	3.21	High	Optimal lipophilicity boost; strong metabolic block.
-Br	0.23	3.38	Moderate	Enhanced hydrophobic binding; exploitable for cross-coupling.
-I	0.18	3.62	Low	Halogen bonding capability; photolabile.

Note: Data derived from standard QSAR models for quinoline antimalarials.

## References

- Gould, R. G., & Jacobs, W. A. (1939).[8] The Synthesis of Certain Substituted Quinolines and 5,6-Benzoquinolines. *Journal of the American Chemical Society*, 61(10), 2890–2895. [Link](#)
- Price, C. C., & Roberts, R. M. (1948). 4,7-Dichloroquinoline.[6][9] *Organic Syntheses*, 28, 38. [Link](#)
- Motati, D. R., Uredi, D., & Watkins, E. B. (2018).[10] A general method for the metal-free, regioselective, remote C–H halogenation of 8-substituted quinolines.[5][7][10][11] *Chemical Science*, 9(7), 1782–1788. [Link](#)

- Doraghi, F., et al. (2024).[12] Transition Metal-Catalyzed C-H Activation/Functionalization of 8-Methylquinolines. *The Chemical Record*, 24(11), e202400116.[12] [Link](#)
- Wilcken, R., et al. (2013).[13] Principles and Applications of Halogen Bonding in Medicinal Chemistry and Chemical Biology. *Journal of Medicinal Chemistry*, 56(4), 1363–1388. [Link](#)

### Need Custom Synthesis?

BenchChem offers custom synthesis for rare earth carbides and specific isotopic labeling.

Email: [info@benchchem.com](mailto:info@benchchem.com) or [Request Quote Online](#).

## Sources

- 1. Quinolin-4-ones: Methods of Synthesis and Application in Medicine - PMC [[pmc.ncbi.nlm.nih.gov](http://pmc.ncbi.nlm.nih.gov)]
- 2. [thieme-connect.com](http://thieme-connect.com) [[thieme-connect.com](http://thieme-connect.com)]
- 3. Gould–Jacobs reaction - Wikipedia [[en.wikipedia.org](http://en.wikipedia.org)]
- 4. [pdf.benchchem.com](http://pdf.benchchem.com) [[pdf.benchchem.com](http://pdf.benchchem.com)]
- 5. A general method for the metal-free, regioselective, remote C–H halogenation of 8-substituted quinolines - *Chemical Science* (RSC Publishing) [[pubs.rsc.org](http://pubs.rsc.org)]
- 6. [benchchem.com](http://benchchem.com) [[benchchem.com](http://benchchem.com)]
- 7. [pubs.rsc.org](http://pubs.rsc.org) [[pubs.rsc.org](http://pubs.rsc.org)]
- 8. Gould-Jacobs Reaction [[drugfuture.com](http://drugfuture.com)]
- 9. [mdpi.com](http://mdpi.com) [[mdpi.com](http://mdpi.com)]
- 10. A general method for the metal-free, regioselective, remote C–H halogenation of 8-substituted quinolines - *Chemical Science* (RSC Publishing) DOI:10.1039/C7SC04107A [[pubs.rsc.org](http://pubs.rsc.org)]
- 11. [researchgate.net](http://researchgate.net) [[researchgate.net](http://researchgate.net)]
- 12. Transition Metal-Catalyzed C-H Activation/Functionalization of 8-Methylquinolines - PubMed [[pubmed.ncbi.nlm.nih.gov](http://pubmed.ncbi.nlm.nih.gov)]
- 13. [namiki-s.co.jp](http://namiki-s.co.jp) [[namiki-s.co.jp](http://namiki-s.co.jp)]
- To cite this document: BenchChem. [Technical Guide: Discovery and Synthesis of Halogenated Quinoline Compounds]. BenchChem, [2026]. [Online PDF]. Available at:

[\[https://www.benchchem.com/product/b11865991#discovery-and-synthesis-of-halogenated-quinoline-compounds\]](https://www.benchchem.com/product/b11865991#discovery-and-synthesis-of-halogenated-quinoline-compounds)

---

### Disclaimer & Data Validity:

The information provided in this document is for Research Use Only (RUO) and is strictly not intended for diagnostic or therapeutic procedures. While BenchChem strives to provide accurate protocols, we make no warranties, express or implied, regarding the fitness of this product for every specific experimental setup.

**Technical Support:** The protocols provided are for reference purposes. Unsure if this reagent suits your experiment? [[Contact our Ph.D. Support Team for a compatibility check](#)]

**Need Industrial/Bulk Grade?** [Request Custom Synthesis Quote](#)

## BenchChem

Our mission is to be the trusted global source of essential and advanced chemicals, empowering scientists and researchers to drive progress in science and industry.

### Contact

Address: 3281 E Guasti Rd

Ontario, CA 91761, United States

Phone: (601) 213-4426

Email: [info@benchchem.com](mailto:info@benchchem.com)