

Application Note: Scalable Synthesis of 4-Iodo-1-methyl-1H-indole

Author: BenchChem Technical Support Team. **Date:** April 2026

Compound of Interest

Compound Name: 4-Iodo-1-methyl-1H-indole

Cat. No.: B11860132

[Get Quote](#)

Executive Summary

This application note details the process optimization and scalable protocols for the

-methylation of 4-iodoindole to produce **4-iodo-1-methyl-1H-indole** (CAS: 885519-01-7). This intermediate is a critical scaffold in the synthesis of kinase inhibitors and 5-HT6 antagonists, where the C4-iodine serves as a regioselective handle for subsequent Suzuki-Miyaura or Buchwald-Hartwig couplings.

While indole methylation is a textbook transformation, the presence of the C4-iodine moiety and the requirement for multi-kilogram scalability introduce specific challenges regarding regioselectivity (N1 vs. C3 alkylation) and process safety (exotherm control and halogen stability).

This guide presents two validated methodologies:

- Method A (High-Throughput): A Sodium Hydride (NaH) mediated route offering maximal conversion (>98%) and N1-selectivity.[1]
- Method B (Process-Safety): A Phase-Transfer Catalysis (PTC) route utilizing KOH/Toluene, designed to eliminate hydrogen gas evolution and reduce engineering controls required for

scale-up.

Reaction Engineering & Mechanism

The Chemoselectivity Challenge

Indole is an ambident nucleophile. Deprotonation yields an indolyl anion that can react at the Nitrogen (N1) or Carbon (C3).

- Kinetic Control (N1): Favored by hard electrophiles (MeI) and highly ionic metal-nitrogen bonds (Na-N, K-N) in polar aprotic solvents (DMF, DMSO).
- Thermodynamic Control (C3): Favored by soft electrophiles, magnesium salts, or non-polar solvents.

To ensure exclusive N1-methylation of 4-iodoindole, we utilize a hard base to form the salt, followed by rapid quenching with Methyl Iodide (MeI).

Reaction Scheme

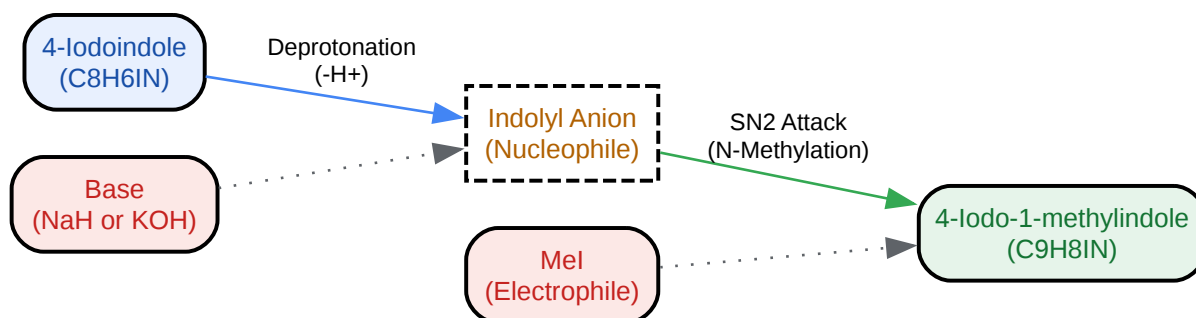

[Click to download full resolution via product page](#)

Figure 1: Mechanistic pathway for the N-methylation of 4-iodoindole.

Experimental Protocols

Method A: NaH/DMF (The "Gold Standard" for Yield)

Best for: Laboratory scale (1g – 100g) where yield and purity are paramount. Critical Hazard: Evolution of Hydrogen gas (

).

Materials

- 4-Iodoindole (1.0 equiv)
- Sodium Hydride (60% dispersion in mineral oil) (1.2 equiv)
- Methyl Iodide (MeI) (1.3 equiv)
- DMF (Anhydrous) (10 vol)

Step-by-Step Protocol

- System Prep: Flame-dry a 3-neck round bottom flask equipped with a magnetic stir bar, nitrogen inlet, and temperature probe.
- Base Charge: Charge NaH (1.2 equiv) into the flask. Add anhydrous DMF (5 vol) and cool to 0 °C using an ice/water bath.
- Substrate Addition: Dissolve 4-iodoindole (1.0 equiv) in DMF (5 vol). Add this solution dropwise to the NaH suspension over 30 minutes.
 - Checkpoint: Observe vigorous bubbling. Maintain internal temperature < 10 °C.
 - Hold: Stir at 0 °C for 30 minutes to ensure complete deprotonation (solution typically turns yellow/brown).
- Alkylation: Add MeI (1.3 equiv) dropwise via syringe or addition funnel.
 - Caution: This step is exothermic. Rate of addition must control temperature to < 20 °C.
- Reaction: Remove ice bath and allow to warm to Room Temperature (RT). Stir for 2 hours.
- IPC (In-Process Control): Check TLC (Hexane/EtOAc 9:1) or HPLC.^{[2][3][4]} Target: < 1% remaining starting material.
- Quench: Cool back to 0 °C. Carefully add saturated

solution (slowly!) to quench excess hydride.

- Workup: Dilute with water (20 vol) and extract with Ethyl Acetate (3 x 10 vol). Wash combined organics with water (2x) and brine (1x). Dry over

.^[3]^[5]^[6]^[7]

- Purification: Concentrate in vacuo. If mineral oil (from NaH) is problematic, wash the crude solid with hexanes or perform a short silica plug filtration.

Method B: Phase-Transfer Catalysis (Scalable & Safer)

Best for: Large scale (>100g to kg) production. Advantage: Avoids

generation and uses cheaper, non-pyrophoric bases.

Materials

- 4-Iodoindole (1.0 equiv)
- Potassium Hydroxide (KOH, powdered) (2.0 equiv)
- Tetrabutylammonium Bromide (TBAB) (0.05 equiv / 5 mol%)
- Methyl Iodide (MeI) (1.5 equiv)
- Toluene (10 vol) or DCM (10 vol)

Step-by-Step Protocol

- Charge: To a reactor, charge 4-iodoindole, Toluene, TBAB, and powdered KOH.
- Temperature: Adjust jacket temperature to 20–25 °C.
- Addition: Add MeI (1.5 equiv) slowly over 1 hour.
 - Note: The biphasic solid-liquid reaction is slower than Method A but easier to control thermally.
- Agitation: High-speed stirring is critical for phase transfer efficiency. Stir for 4–6 hours.

- IPC: Monitor conversion. If stalled, add additional KOH (0.5 equiv).
- Workup: Filter off the inorganic solids (, excess). Wash the filtrate with water.[\[4\]](#)[\[5\]](#)[\[7\]](#)
- Isolation: Concentrate the Toluene layer. The product often crystallizes upon cooling or solvent swap to Heptane.

Workup and Purification Workflow

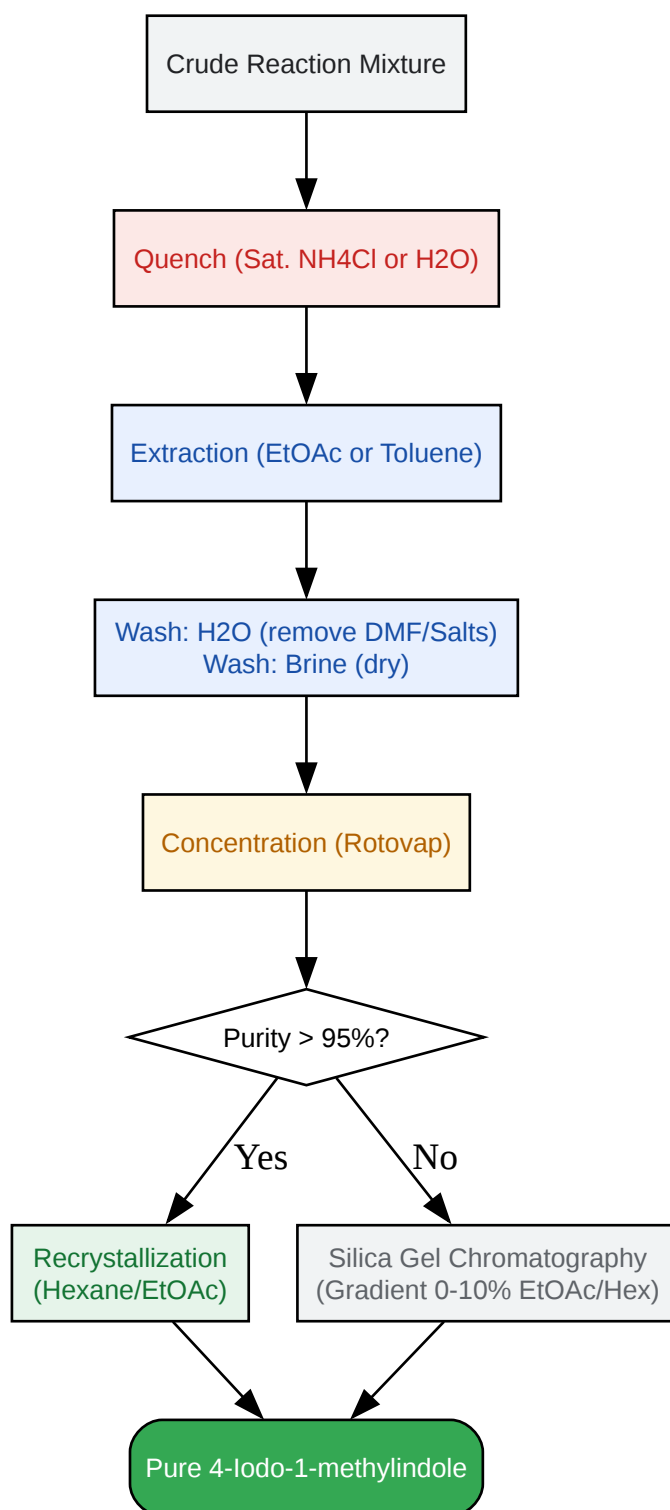

[Click to download full resolution via product page](#)

Figure 2: Downstream processing decision tree for isolation of high-purity intermediate.

Analytical Data & Specifications

Product: **4-Iodo-1-methyl-1H-indole** Appearance: Pale yellow oil or low-melting solid (dependent on purity).

Parameter	Specification	Notes
1H NMR (CDCl ₃)	3.82 (s, 3H, N-Me)	Diagnostic singlet. Absence of NH (~8.4 ppm).
1H NMR (Aromatic)	7.55 (d, 1H), 7.15 (d, 1H), 6.95 (t, 1H)	Characteristic indole pattern.
HPLC Purity	> 98.0% (a/a)	Critical for subsequent metal-catalyzed couplings.
Water Content	< 0.1%	Karl Fischer titration.
Residual Solvent	DMF < 880 ppm	ICH Q3C limits.

Process Safety & Troubleshooting

Critical Process Parameters (CPPs)

- **Temperature Control:** During MeI addition, T > 30°C increases the risk of C3-methylation (impurity). Keep T < 20°C.
- **Stoichiometry:** Excess MeI (>1.5 equiv) can lead to quaternization (formation of dimethylindolium salts).
- **Water Content:** In Method A, wet DMF destroys NaH, generating excess heat and reducing yield. DMF KF must be < 0.05%.

Troubleshooting Guide

Issue	Probable Cause	Corrective Action
Low Conversion	Old NaH or wet solvent.	Use fresh NaH. Dry DMF over molecular sieves.
C3-Methylation	Reaction too hot or wrong solvent.	Ensure T < 10°C during addition. Ensure polar solvent (DMF) is used for Method A.
Dark Coloration	Oxidation of indole.	Degas solvents with prior to use. Add antioxidant (BHT) if storing.

References

- BenchChem.Large-Scale Synthesis of 4-Iodo-3-methyl-1H-indazole (Analogous Protocol). Technical Support Center. [Link](#)
- Organic Syntheses.1-Methylindole.[5][6] Org.[4][5][6][7][8][9][10] Synth. 1974, 54, 58. [Link](#)
- National Institutes of Health (PMC).Monoselective N-Methylation of Amides, Indoles, and Related Structures. PMC9536640. [Link](#)
- Jiang, X., et al.A Practical Method for N-Methylation of Indoles Using Dimethyl Carbonate.[4] Org.[4][5][6][7][8][9][10] Process Res. Dev. 2001.[9] (Green Chemistry Alternative).[11] [Link](#)
- Beilstein Journals.Regioselective N-alkylation of the 1H-indazole scaffold. Beilstein J. Org. Chem. 2021, 17, 1969–1978. [Link](#)

Need Custom Synthesis?

BenchChem offers custom synthesis for rare earth carbides and specific isotopic labeling.

Email: info@benchchem.com or [Request Quote Online](#).

Sources

- 1. BJOC - Regioselective N-alkylation of the 1H-indazole scaffold; ring substituent and N-alkylating reagent effects on regioisomeric distribution [[beilstein-journals.org](#)]
- 2. [patentimages.storage.googleapis.com](#) [[patentimages.storage.googleapis.com](#)]
- 3. [pdf.benchchem.com](#) [[pdf.benchchem.com](#)]
- 4. [researchgate.net](#) [[researchgate.net](#)]
- 5. Organic Syntheses Procedure [[orgsyn.org](#)]
- 6. [rjpbcs.com](#) [[rjpbcs.com](#)]
- 7. [rsc.org](#) [[rsc.org](#)]
- 8. EP1829872B1 - Processes for production of indole compounds - Google Patents [[patents.google.com](#)]
- 9. [re.public.polimi.it](#) [[re.public.polimi.it](#)]
- 10. CN101157650B - Preparation method of methyl indole-1-carboxylate and derivatives thereof - Google Patents [[patents.google.com](#)]
- 11. [researchgate.net](#) [[researchgate.net](#)]
- To cite this document: BenchChem. [Application Note: Scalable Synthesis of 4-Iodo-1-methyl-1H-indole]. BenchChem, [2026]. [Online PDF]. Available at: [<https://www.benchchem.com/product/b11860132/docs#application-note-scalable-synthesis-of-4-iodo-1-methyl-1h-indole>]

Disclaimer & Data Validity:

The information provided in this document is for Research Use Only (RUO) and is strictly not intended for diagnostic or therapeutic procedures. While BenchChem strives to provide accurate protocols, we make no warranties, express or implied, regarding the fitness of this product for every specific experimental setup.

Technical Support: The protocols provided are for reference purposes. Unsure if this reagent suits your experiment?

Need Industrial/Bulk Grade? [Request Custom Synthesis Quote](#)

BenchChem

Our mission is to be the trusted global source of essential and advanced chemicals, empowering scientists and researchers to drive progress in science and industry.

Contact

Address: 3281 E Guasti Rd
Ontario, CA 91761, United States
Phone: (601) 213-4426
Email: info@benchchem.com

[Contact our Ph.D. Support Team for a compatibility check](#)