

Optimizing Suzuki coupling yield with 3-iodo-indazole substrates

Author: BenchChem Technical Support Team. **Date:** May 2026

Compound of Interest

Compound Name: *3-Iodo-4-methoxy-1-methyl-1H-indazole*

Cat. No.: *B11839617*

[Get Quote](#)

Technical Support Center: 3-Iodo-Indazole Cross-Coupling

Executive Summary & Chemical Context[1][2][3][4][5][6][7][8][9]

The Challenge: Coupling 3-iodo-1H-indazole substrates presents a unique "bimodal" failure mechanism compared to standard aryl halides. The core issue is the amphoteric nature of the indazole core:

- Acidity (

): The N1-H proton is acidic. Standard Suzuki bases (carbonates, phosphates) deprotonate this position, creating an indazolyl anion. This species is an excellent ligand for Palladium, often forming stable $[Pd(\text{Indazolyl})L_2]$ complexes that stall the catalytic cycle (catalyst poisoning).

- Coordination: The N₂ nitrogen is pyridine-like and can competitively bind to the metal center, displacing phosphine ligands.

The Solution Matrix: Success requires a binary decision early in your workflow: Protect the Nitrogen (High Reliability) or Tune the System for Unprotected Substrates (High Efficiency/Step-Economy).

Decision Matrix & Workflow (Visual)

The following logic tree outlines the recommended optimization path based on your substrate's stability and your lab's capabilities.

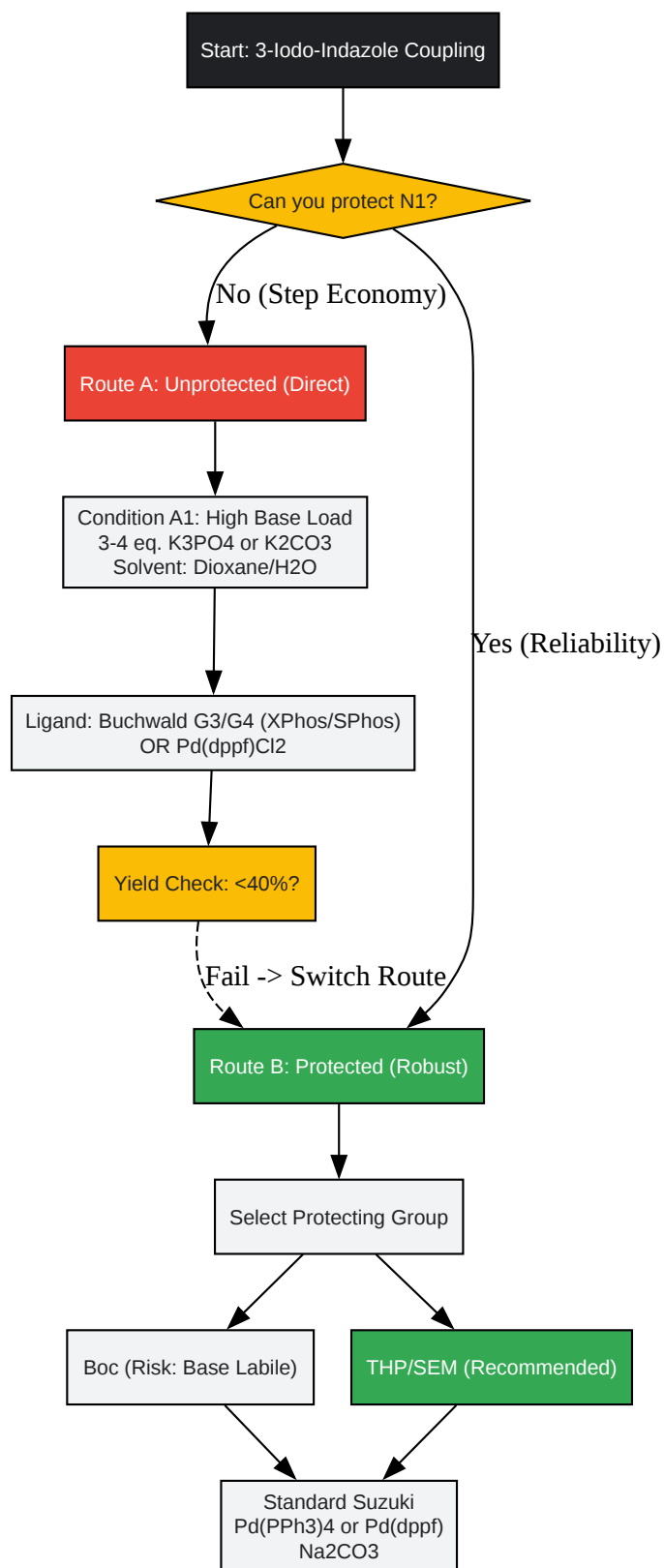

[Click to download full resolution via product page](#)

Caption: Optimization logic tree for 3-iodo-indazole coupling. Route A prioritizes speed; Route B prioritizes yield reliability.

Module 1: The "Unprotected" Strategy

Use Case: You need to avoid protection/deprotection steps, or your substrate has electron-withdrawing groups (EWGs) like nitro/cyano at C5/C7.

Troubleshooting Guide

Q: Why does my reaction stall at 20% conversion even with fresh catalyst? A: You are likely experiencing "Anionic Poisoning." When you use 1.5–2.0 equivalents of base, you generate the indazolyl anion. This anion binds to the Pd(II) intermediate more tightly than the boronic acid can transmetallate.

- The Fix: Increase base concentration to 3.0–4.0 equivalents. This forces the equilibrium but requires a ligand that prevents the Pd center from being "choked" by the nitrogen.

Q: Which catalyst system works for unprotected indazoles? A: Stop using

. It is too labile.

- Recommendation: Use Buchwald Precatalysts (Gen 2/3) with bulky biaryl phosphine ligands.
 - XPhos Pd G3: Excellent for steric bulk.
 - SPhos Pd G3: Universal choice for heteroaryl chlorides/iodides.
 - Alternative:

is a robust, cheaper alternative that resists N-coordination better than triphenylphosphine.

Protocol: Optimized Unprotected Coupling

Valid for: 3-iodo-1H-indazole + Aryl Boronic Acid

Component	Equivalents	Notes
Substrate	1.0	3-iodo-1H-indazole
Boronic Acid	1.5 - 2.0	Excess required due to potential protodeboronation.
Catalyst	0.02 - 0.05 (2-5 mol%)	XPhos Pd G3 or Pd(dppf)Cl ₂
Base	3.0 - 4.0	(preferred) or .
Solvent	0.1 - 0.2 M	1,4-Dioxane : Water (4:1). Water is critical for boronic acid solubility.
Temp/Time	100°C (12h) or 120°C (MW 40min)	Microwave is superior for difficult substrates.

Critical Note: If your substrate has an EWG (e.g., -NO₂) on the ring, the unprotected reaction often works better than the protected version because the anion is stabilized and less nucleophilic toward Palladium [1].

Module 2: The "Protected" Strategy (Gold Standard)

Use Case: Complex substrates, late-stage functionalization, or when Route A fails.

Troubleshooting Guide

Q: I used N-Boc protection, but I see deprotected starting material (3-iodo-1H-indazole) in the LCMS. A: Boc groups are thermally unstable in aqueous base at >80°C.

- The Fix: Switch to THP (Tetrahydropyranyl) or SEM (2-(Trimethylsilyl)ethoxymethyl).
 - THP: Installed easily (DHP, pTsoH), stable to base, removed with mild acid.
 - SEM: extremely robust, but harder to put on/take off.

- If you MUST use Boc: Lower the temperature to 60-70°C and use a more active catalyst (e.g.,) to compensate for the lower rate [3].

Q: Does the protecting group position matter (N1 vs N2)? A: Yes, but you usually get N1 thermodynamically. N1-protection prevents the "poisoning" effect completely, restoring the reactivity of the 3-iodo bond to that of a standard aryl iodide.

Comparative Data: Protecting Group Performance[2]

Protecting Group	Stability (Suzuki Conditions)	Removal Difficulty	Recommendation Score
None (H)	Low (Poisoning risk)	N/A	★★★ (Situational)
Boc	Low (Deprotects >80°C)	Easy (TFA/HCl)	★ (Avoid if possible)
THP	High	Easy (HCl/MeOH)	★★★★★ (Best Balance)
SEM	Very High	Medium (TBAF)	★★★★★ (For tough cases)
Tosyl	Medium	Medium	★★★

Module 3: Mechanism of Failure (Why protocols fail)

Understanding the failure mode allows you to choose the right fix.

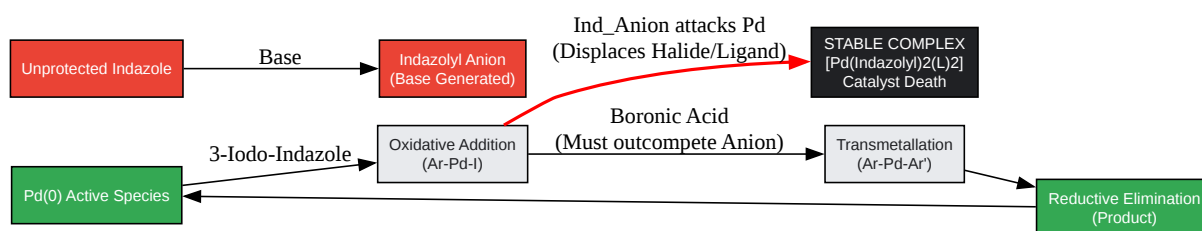

[Click to download full resolution via product page](#)

Caption: The "Death Loop" (Red) occurs when the indazolyl anion outcompetes the boronic acid during transmetallation.

FAQ: Advanced Troubleshooting

Q: My LCMS shows the de-iodinated product (indazole). What happened? A: This is Protodehalogenation. It happens when the catalytic cycle initiates (Oxidative Addition) but Transmetallation is too slow. The Pd species grabs a hydride (from solvent or impurities) and reductively eliminates.

- Fix:
 - Use anhydrous solvents (DMF/Dioxane) if possible (switch base to CsF or dry).
 - Increase the concentration of Boronic Acid (push kinetics).
 - Switch to a catalyst with a faster Transmetallation rate (e.g., Pd-116 or XPhos Pd G3).

Q: Can I use microwave irradiation? A: Yes, it is highly recommended for 3-iodoindazoles.

- Protocol: 120°C for 20-40 minutes often pushes the reaction to completion before catalyst deactivation can occur. Unprotected substrates tolerate this well [1].

Q: How do I remove the Palladium black residues from the product? A: Indazoles are "sticky" for metals due to the nitrogens.

- Fix: Treat the crude organic layer with Thiol-functionalized Silica (SiliaMetS® Thiol) or wash with an aqueous solution of N-Acetylcysteine before column chromatography.

References

- Vera, G., et al. (2018).[1][2] "Suzuki-Type Cross-Coupling Reaction of Unprotected 3-Iodoindazoles with Pinacol Vinyl Boronate: An Expeditive C-3 Vinylation of Indazoles under Microwave Irradiation." *Molecules*, 23(8), 2051.[1]

- Lott, J., et al. (2023). "The C-3 Functionalization of 1H-Indazole through Suzuki–Miyaura Cross-Coupling Catalyzed by a Ferrocene-Based Divalent Palladium Complex." *Molecules*, 28(7), 2908.
- Billingsley, K., & Buchwald, S. L. (2007). "An Improved System for the Suzuki–Miyaura Coupling of Heteroaryl Halides." *Journal of the American Chemical Society*, 129(11), 3358–3366.
- Hauser, M. R., et al. (2014). "Suzuki-Miyaura Cross-Coupling of Unprotected, Nitrogen-Rich Heterocycles: Substrate Scope and Mechanistic Investigation." *Journal of Organic Chemistry*, 79(21), 10256–10268.

Need Custom Synthesis?

BenchChem offers custom synthesis for rare earth carbides and specific isotopic labeling.

Email: info@benchchem.com or [Request Quote Online](#).

Sources

- [1. Suzuki-Type Cross-Coupling Reaction of Unprotected 3-Iodoindazoles with Pinacol Vinyl Boronate: An Expeditive C-3 Vinylation of Indazoles under Microwave Irradiation - PubMed \[pubmed.ncbi.nlm.nih.gov\]](#)
- [2. researchgate.net \[researchgate.net\]](#)
- To cite this document: BenchChem. [Optimizing Suzuki coupling yield with 3-iodo-indazole substrates]. BenchChem, [2026]. [Online PDF]. Available at: [<https://www.benchchem.com/product/b11839617/docs#optimizing-suzuki-coupling-yield-with-3-iodo-indazole-substrates>]

Disclaimer & Data Validity:

The information provided in this document is for Research Use Only (RUO) and is strictly not intended for diagnostic or therapeutic procedures. While BenchChem strives to provide accurate protocols, we make no warranties, express or implied, regarding the fitness of this product for every specific experimental setup.

Technical Support: The protocols provided are for reference purposes. Unsure if this reagent suits your experiment?

Need Industrial/Bulk Grade? [Request Custom Synthesis Quote](#)

BenchChem

Our mission is to be the trusted global source of essential and advanced chemicals, empowering scientists and researchers to drive progress in science and industry.

Contact

Address: 3281 E Guasti Rd
Ontario, CA 91761, United States
Phone: (601) 213-4426
Email: info@benchchem.com

[Contact our Ph.D. Support Team for a compatibility check](#)