

Application Note: Strategic Design & Synthesis of Fluorescent Probes via 7-Bromoquinoline Functionalization

Author: BenchChem Technical Support Team. **Date:** April 2026

Compound of Interest

Compound Name:	7-Bromoquinoline-2,3-dicarboxylic acid
CAS No.:	892874-38-3
Cat. No.:	B11838143

[Get Quote](#)

Abstract

The 7-bromoquinoline scaffold represents a privileged starting point for the development of "push-pull" Intramolecular Charge Transfer (ICT) fluorescent probes. Unlike the more common 2- or 4-substituted quinolines, the 7-position offers a unique vector for extending conjugation and introducing electron-donating groups (EDGs) para to the nitrogen center. This Application Note details a modular synthetic workflow for transforming commercially available 7-bromoquinoline into high-performance bioimaging tools. We focus on Palladium-catalyzed cross-coupling (Suzuki-Miyaura) followed by N-alkylation to engineer red-shifted, environmentally sensitive fluorophores.

Introduction: The 7-Bromoquinoline Advantage

In fluorescent probe design, the quinoline ring acts as a robust electron-withdrawing core. The specific utility of 7-bromoquinoline lies in its electronic geometry. When the quinoline nitrogen is

quaternized (alkylated), it becomes a strong electron acceptor. A substituent at the 7-position is electronically conjugated to this nitrogen, allowing for the construction of a linear Donor-

-Acceptor (D-

-A) system.

Mechanistic Logic (ICT & Solvatochromism)

The primary mechanism exploited here is Intramolecular Charge Transfer (ICT).

- Ground State: The electron density is distributed across the molecule.
- Excited State: Upon photoexcitation, electron density shifts from the donor (at C7) to the acceptor (Quinolinium Nitrogen).
- Environmental Sensitivity: This large dipole moment change makes these probes highly sensitive to solvent polarity (solvatochromism) and micro-viscosity (molecular rotor effect), making them ideal for organelle-specific imaging (e.g., Mitochondria, RNA).

Strategic Design Workflow

The synthesis follows a "Function-First" approach:

- Step 1: Conjugation Extension (Suzuki Coupling). Replace the bromine with an electron-rich aryl ring.
- Step 2: Acceptor Activation (N-Alkylation). Convert the quinoline to a quinolinium cation to lower the LUMO energy and red-shift emission.

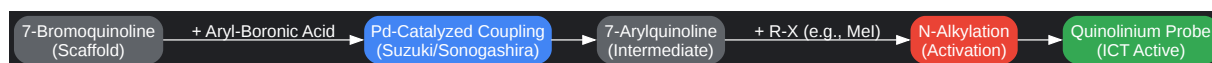

[Click to download full resolution via product page](#)

Figure 1: Modular synthetic workflow transforming the halogenated scaffold into a functional ICT probe.

Experimental Protocols

Protocol A: Suzuki-Miyaura Coupling at C7

Objective: To introduce an electron-donating phenyl or heterocyclic group at the 7-position.

Target: 7-(4-methoxyphenyl)quinoline (Example).

Reagents:

- 7-Bromoquinoline (1.0 equiv)[1]
- 4-Methoxyphenylboronic acid (1.2 equiv)
- Catalyst:
(5 mol%) or
(for sterically hindered substrates)
- Base:
(2.0 M aqueous solution)
- Solvent: 1,4-Dioxane (degassed)

Procedure:

- Setup: Flame-dry a two-neck round-bottom flask equipped with a condenser and a magnetic stir bar.
- Loading: Add 7-bromoquinoline (1.0 mmol, 208 mg) and 4-methoxyphenylboronic acid (1.2 mmol, 182 mg) to the flask.
- Inert Atmosphere: Evacuate and backfill with Argon () three times.[1][2] This is a Critical Checkpoint: Oxygen irreversibly oxidizes Pd(0) to Pd(II), killing the catalytic cycle.
- Solvent Addition: Syringe in degassed 1,4-dioxane (10 mL) and 2.0 M

(2 mL).

- Catalyst Addition: Under a positive stream of Argon, quickly add (58 mg). The solution typically turns yellow/orange.
- Reaction: Heat to reflux (100°C) for 12–16 hours. Monitor by TLC (Hexane:EtOAc 4:1). The starting bromide () should disappear, and a fluorescent product spot should appear.
- Workup: Cool to room temperature. Filter through a Celite pad to remove Palladium black. Dilute with EtOAc, wash with brine (), dry over , and concentrate.
- Purification: Flash column chromatography (Silica gel, Gradient 0-20% EtOAc in Hexane).

Expert Insight: If the reaction stalls, add a fresh portion of boronic acid (0.5 equiv) and catalyst (2 mol%). Boronic acids can undergo protodeboronation (degradation) over long reflux times.

Protocol B: N-Alkylation (Quaternization)

Objective: To activate the fluorophore by creating the cationic quinolinium center. Target: 7-(4-methoxyphenyl)-1-methylquinolin-1-ium iodide.

Reagents:

- 7-(4-methoxyphenyl)quinoline (from Protocol A)
- Methyl Iodide (MeI) (Caution: Neurotoxin)
- Solvent: Acetonitrile () or Toluene

Procedure:

- Safety First: Perform this reaction in a well-ventilated fume hood. MeI is a volatile alkylating agent.
- Dissolution: Dissolve the intermediate (0.5 mmol) in anhydrous Acetonitrile (5 mL) in a pressure tube or sealed vial.
- Alkylation: Add Methyl Iodide (5.0 equiv, excess).
- Reflux: Seal the tube and heat to 80°C for 6–12 hours.
 - Observation: The reaction mixture usually darkens, and a precipitate (the product salt) often forms.
- Workup (Precipitation): Cool the vial to room temperature. Add cold Diethyl Ether (, 20 mL) to force full precipitation of the product.
- Isolation: Filter the solid, wash extensively with to remove unreacted starting material and MeI.
- Drying: Vacuum dry the solid.[3] Quinolinium salts are often hygroscopic; store in a desiccator.

Expert Insight: If the product serves as a mitochondrial probe, the lipophilicity of the counter-ion matters. You can perform an ion exchange (e.g., using

) to swap Iodide for Hexafluorophosphate, improving cell membrane permeability.

Characterization & Data Interpretation

Spectral Validation

Upon quaternization, expect a significant bathochromic shift (Red Shift) due to the lowered LUMO energy of the cationic system.

Table 1: Expected Photophysical Shifts (Example Data)

Compound Stage	Solvent	(nm)	(nm)	Stokes Shift (nm)	Visual Color
7-Bromoquinoline	DCM	~310	~380	70	UV/Blue
7-Aryl-Intermediate	DCM	~340	~420	80	Blue/Cyan
Quinolinium Probe	DCM	~480	~590	110	Orange/Red
Quinolinium Probe	Water	~470	~610	140	Red (Weak)

Note: In water, ICT probes often suffer from fluorescence quenching due to H-bonding. They typically "turn on" in viscous environments or upon binding to biomolecules (DNA/RNA/Proteins).

Mechanism of Action (Signal Transduction)

The probe operates via a push-pull mechanism. The efficiency of this transfer determines the Quantum Yield (

).[4]

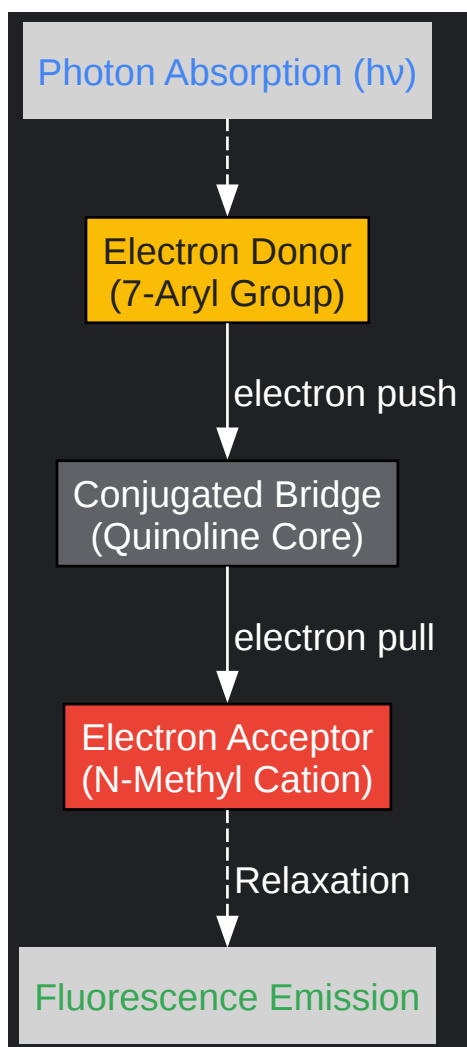

[Click to download full resolution via product page](#)

Figure 2: The Intramolecular Charge Transfer (ICT) pathway. The N-methylation is the critical step that increases the 'pull' strength, shifting emission to longer wavelengths.

Troubleshooting & Critical Checkpoints

- Catalyst Death (Black Precipitate early on):
 - Cause: Oxygen in the solvent or poor quality Boronic Acid.
 - Fix: Freeze-pump-thaw degas solvents. Use fresh catalyst.
- Incomplete Alkylation:

- Cause: Steric hindrance from peri-hydrogens (H8 position) interacting with the N-methyl group.
- Fix: Switch to a more reactive alkylating agent (Methyl Triflate - Extreme Caution required) or increase temperature/time in a sealed tube.
- Purification Issues:
 - Issue: Quinolinium salts streak on silica.
 - Fix: Switch to Alumina (Neutral) or use Reverse-Phase (C18) chromatography. Alternatively, use Methanol/DCM mixtures with 1%

(though this may deprotonate if the probe is pH sensitive).

References

- Suzuki-Miyaura Coupling Mechanism & Protocols
 - Miyaura, N., & Suzuki, A. (1995). Palladium-Catalyzed Cross-Coupling Reactions of Organoboron Compounds. *Chemical Reviews*.
- Quinolinium Probes for RNA/Mitochondria (QUCO-1)
 - Wang, L., et al. (2023).^[3] Fluorescent Quinolinium Derivative as Novel Mitochondria Probe and Function Modulator by Targeting Mitochondrial RNA.^[3] *Molecules*.
- 7-Substituted Quinoline Synthesis via Pd-Catalysis
 - BenchChem Application Note. (2025).^{[1][2][4][5][6][7][8][9]} Application Notes and Protocols: Suzuki-Miyaura Coupling with Brominated Quinolines.
 - (General Protocol Reference)
- ICT Probe Design Principles
 - Xiao, Y., et al. (2010).^[6] New Strategies for Fluorescent Probe Design in Medical Diagnostic Imaging. *Chemical Reviews*.

Need Custom Synthesis?

BenchChem offers custom synthesis for rare earth carbides and specific isotopic labeling.

Email: info@benchchem.com or [Request Quote Online](#).

Sources

- [1. pdf.benchchem.com \[pdf.benchchem.com\]](https://pdf.benchchem.com)
- [2. pdf.benchchem.com \[pdf.benchchem.com\]](https://pdf.benchchem.com)
- [3. mdpi.com \[mdpi.com\]](https://mdpi.com)
- [4. pdf.benchchem.com \[pdf.benchchem.com\]](https://pdf.benchchem.com)
- [5. researchgate.net \[researchgate.net\]](https://researchgate.net)
- [6. Quinoline-substituted excited-state intramolecular proton transfer fluorophores as stimuli-sensitive dual-state fluorophores - Organic Chemistry Frontiers \(RSC Publishing\)](#)
[DOI:10.1039/D5QO00639B \[pubs.rsc.org\]](https://doi.org/10.1039/D5QO00639B)
- [7. Synthesis of quinoline-based fluorescence probe for Zn\(II\) sensing and its applications in anti-counterfeiting ink and imaging in plants and living cells - Arabian Journal of Chemistry \[arabjchem.org\]](#)
- [8. pdf.benchchem.com \[pdf.benchchem.com\]](https://pdf.benchchem.com)
- [9. researchgate.net \[researchgate.net\]](https://researchgate.net)
- To cite this document: BenchChem. [Application Note: Strategic Design & Synthesis of Fluorescent Probes via 7-Bromoquinoline Functionalization]. BenchChem, [2026]. [Online PDF]. Available at: [<https://www.benchchem.com/product/b11838143/docs#application-note-strategic-design-synthesis-of-fluorescent-probes-via-7-bromoquinoline-functionalization>]

Disclaimer & Data Validity:

The information provided in this document is for Research Use Only (RUO) and is strictly not intended for diagnostic or therapeutic procedures. While BenchChem strives to provide accurate protocols, we make no warranties, express or implied, regarding the fitness of this product for every specific experimental setup.

Technical Support: The protocols provided are for reference purposes. Unsure if this reagent suits your experiment?

Need Industrial/Bulk Grade? [Request Custom Synthesis Quote](#)

BenchChem

Our mission is to be the trusted global source of essential and advanced chemicals, empowering scientists and researchers to drive progress in science and industry.

Contact

Address: 3281 E Guasti Rd
Ontario, CA 91761, United States
Phone: (601) 213-4426
Email: info@benchchem.com

[Contact our Ph.D. Support Team for a compatibility check](#)