

# Technical Guide: Validation of CRBN Binding Affinity Using Competition Assays

**Author:** BenchChem Technical Support Team. **Date:** April 2026

## Compound of Interest

Compound Name: Thalidomide-NH-PEG3-CH2CHO

Cat. No.: B11832995

[Get Quote](#)

## Executive Summary

This guide provides a rigorous technical comparison of methodologies for determining the binding affinity of small molecules (IMiDs, CELMoDs, and PROTAC linkers) to the Cereblon (CRBN) E3 ligase complex. We evaluate the performance of High-Sensitivity TR-FRET Competition Assays against the kinetic "gold standard" of Surface Plasmon Resonance (SPR) and legacy Fluorescence Polarization (FP) methods.

Key Takeaway: While SPR provides real-time kinetics (

, modern TR-FRET assays utilizing high-affinity tracers (e.g., BODIPY-based) offer superior throughput and sensitivity comparable to SPR, provided that thermodynamic corrections (Cheng-Prusoff) are applied correctly.

## Scientific Context: The CRBN-DDB1-CUL4A Complex

Cereblon (CRBN) functions as the substrate receptor for the CRL4 E3 ubiquitin ligase complex. [1][2] Immunomodulatory drugs (IMiDs) like thalidomide bind to the tri-tryptophan pocket of

CRBN, altering its surface topology to recruit neosubstrates (e.g., IKZF1/3) for ubiquitination.

In drug discovery, particularly for PROTACs, accurately measuring the binary affinity (

or

) of a ligand to CRBN is the critical first step before assessing ternary complex formation.

## Mechanism of Action: Competition Assay

In a competition assay, a known fluorescent "tracer" is bound to CRBN.[3][4] The test compound displaces this tracer. The signal loss is proportional to the inhibitor's affinity.

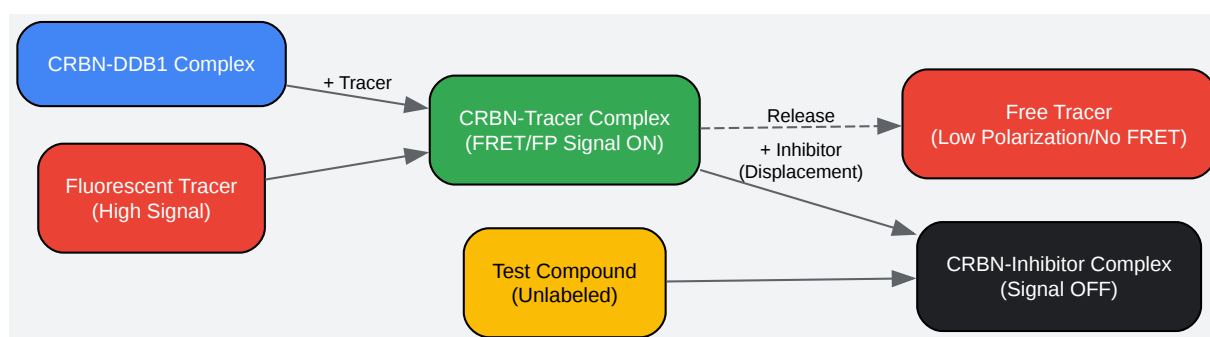

[Click to download full resolution via product page](#)

Figure 1: Mechanism of competitive displacement. The test compound competes with a labeled tracer for the CRBN binding pocket.

## Methodology Comparison: TR-FRET vs. SPR vs. FP[5]

The following table synthesizes performance data, highlighting the sensitivity gap between legacy FP and modern TR-FRET.

Feature	High-Sensitivity TR-FRET	Surface Plasmon Resonance (SPR)	Standard Fluorescence Polarization (FP)
Readout	Ratiometric (665/620 nm)	Refractive Index Unit (RU)	Milli-Polarization (mP)
Throughput	High (384/1536-well)	Low/Medium	High
Sensitivity	High (resolvable < 10 nM)	High (Label-free detection)	Moderate (Limited by tracer intensity)
Data Output	(convertible to )	,	,
Sample Consumption	Low (< 10 L/well)	High (Flow-based)	Low
Key Limitation	Requires specific fluorophore pair optimization	Expensive; immobilization artifacts	Susceptible to autofluorescence interference

## Comparative Data: Binding Affinities ( / )

Note: Values represent consensus ranges from literature. TR-FRET sensitivity depends heavily on the tracer used (e.g., Cy5 vs. BODIPY).

Compound	SPR ( ) [1, 2]	TR-FRET ( ) [3, 4]	FP ( ) [3]
Pomalidomide	~100 - 300 nM	3.0 - 6.4 nM	~150 nM
Lenalidomide	1.5 - 3.0 M	4.2 - 8.9 nM	~170 nM
Thalidomide	~3.0 M	10.6 nM*	~250 nM

\*Note: The significantly lower (tighter) values in modern TR-FRET (Source 3) reflect the use of high-affinity BODIPY tracers and optimized buffers compared to earlier Cy5-based assays. This highlights the importance of "Assay Sensitivity" – a weaker tracer (FP) often yields higher apparent

values if not perfectly equilibrated.

## Detailed Protocol: High-Sensitivity TR-FRET Competition Assay

Role: Application Scientist Validation

This protocol utilizes a Terbium (Tb) cryptate donor conjugated to anti-tag antibodies and a Red acceptor (e.g., BODIPY or Alexa647) conjugated to a Thalidomide analog.

### Reagents & Equipment[1][3][4]

- Protein: Human His-tagged CRBN-DDB1 complex.[5]
- Tracer: Thalidomide-Red Acceptor (optimized ~3-5 nM).
- Detection: Anti-6His-Tb Cryptate Donor.

- Buffer: 50 mM HEPES pH 7.5, 150 mM NaCl, 0.1% Pluronic F-127 (Crucial for preventing stickiness), 1 mM DTT.
- Plate: 384-well Low Volume White ProxiPlate.[1]

## Step-by-Step Workflow

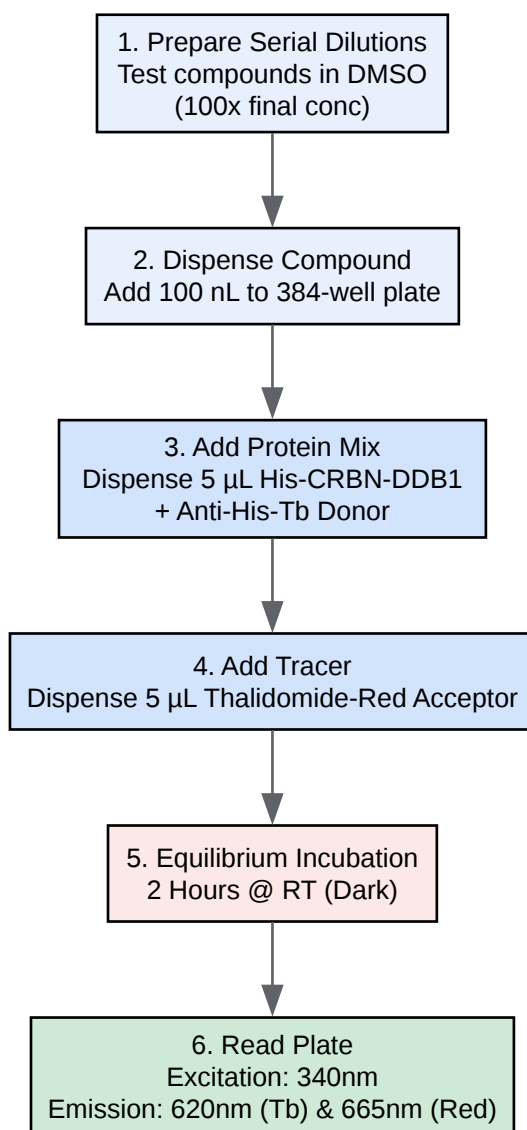

[Click to download full resolution via product page](#)

Figure 2: High-throughput workflow for TR-FRET competition screening.

## Critical "Self-Validating" Controls

To ensure data trustworthiness, every plate must include:

- Max Signal ( ): Protein + Tracer + DMSO (No inhibitor). Defines 100% binding.
- Min Signal (NSB): Buffer + Tracer (No protein) OR Protein + Tracer + Excess Competitor (e.g., 100 M Pomalidomide). Defines 0% binding.
- Z' Factor: Must be > 0.5. Calculated using:

## Data Analysis: From to

A common error in CRBN research is reporting

as affinity.

is dependent on the concentration of the tracer and the protein. You must convert to

using the Cheng-Prusoff equation to allow valid comparisons between different assay formats (e.g., comparing your TR-FRET data to literature SPR data).

## The Mathematical Logic

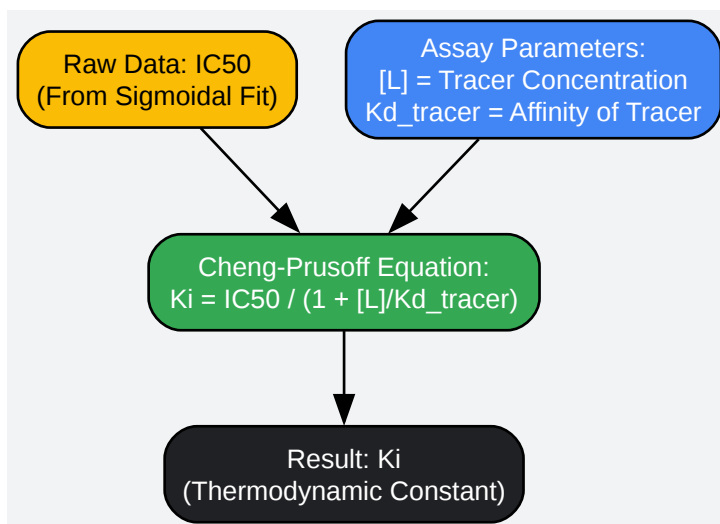

[Click to download full resolution via product page](#)

Figure 3: Logic flow for converting assay-dependent IC50 to constant Ki.

Expert Insight: If you use a tracer concentration significantly below its

(  
) , then

. This is why high-sensitivity assays (like the BODIPY-based TR-FRET) often report lower values that are closer to the true affinity than older assays requiring high tracer concentrations [5].

## Critical Analysis & Recommendation

### When to use TR-FRET:

- Screening: Ideal for screening libraries of PROTAC linkers or novel warheads.
- Throughput: When you need to test hundreds of compounds.[6]
- Stability: Homogeneous mix-and-read format avoids the washing steps of ELISA that can disrupt weak binders.

### When to use SPR:

- Mechanism of Action: When you need to know how fast a drug binds (  
) or dissociates (  
) . For example, a PROTAC with a slow dissociation rate (long residence time) may be more potent in cells despite a similar  
.
- Ternary Complex: SPR is superior for visualizing the "Hook Effect" and cooperativity (  
) in real-time [6].

## Conclusion

For routine validation of binding affinity, TR-FRET is the superior choice for efficiency and cost, provided a high-affinity tracer is used. Data generated correlates well with SPR when corrected for tracer competition.

## References

- Fischer, E. S., et al. (2014).[5] Structure of the DDB1-CRBN E3 ubiquitin ligase in complex with thalidomide.[2] *Nature*, 512(7512), 49-53. [Link](#)
- Chamberlain, P. P., et al. (2014). Structure of the human Cereblon-DDB1-lenalidomide complex reveals basis for responsiveness to thalidomide analogs.[5] *Nature Structural & Molecular Biology*, 21, 803–809. [Link](#)
- Liu, J., et al. (2018). Development of BODIPY FL Thalidomide as a High-Affinity Fluorescent Probe for Cereblon in a Time-Resolved Fluorescence Resonance Energy Transfer Assay.[7] *Bioconjugate Chemistry*, 29(6), 1932-1941. [Link](#)
- Matyskiela, M. E., et al. (2018).[8] A Cereblon Modulator (CC-220) with Improved Degradation of Ikaros and Aiolos. *Journal of Medicinal Chemistry*, 61(2), 535-542. [Link](#)
- Nikolovska-Coleska, Z., et al. (2004). Development and optimization of a fluorescence polarization assay for the molecular interaction between the Bcl-2/Bcl-xL and Smac/DIABLO proteins. *Analytical Biochemistry*, 332(2), 261-273. [Link](#) (Reference for Cheng-Prusoff application in FP/FRET).
- Roy, M. J., et al. (2019). SPR-Measured Dissociation Kinetics of PROTAC Ternary Complexes Influence Target Degradation Efficiency. *ACS Chemical Biology*, 14(7), 1648–1661. [Link](#)

### Need Custom Synthesis?

BenchChem offers custom synthesis for rare earth carbides and specific isotopic labeling.

Email: [info@benchchem.com](mailto:info@benchchem.com) or [Request Quote Online](#).

## Sources

- [1. HTRF Cereblon Binding Kit, 500 Assay Points | Revvity \[revvity.com\]](#)
- [2. pubs.acs.org \[pubs.acs.org\]](#)
- [3. pdf.benchchem.com \[pdf.benchchem.com\]](#)
- [4. pdf.benchchem.com \[pdf.benchchem.com\]](#)
- [5. biorxiv.org \[biorxiv.org\]](#)
- [6. biorxiv.org \[biorxiv.org\]](#)
- [7. Development of BODIPY FL Thalidomide as a High-Affinity Fluorescent Probe for Cereblon in a Time-Resolved Fluorescence Resonance Energy Transfer Assay - PMC \[pmc.ncbi.nlm.nih.gov\]](#)
- [8. A Cell-based Target Engagement Assay for the Identification of Cereblon E3 Ubiquitin Ligase Ligands and Their Application in HDAC6 Degradors - PMC \[pmc.ncbi.nlm.nih.gov\]](#)
- To cite this document: BenchChem. [Technical Guide: Validation of CRBN Binding Affinity Using Competition Assays]. BenchChem, [2026]. [Online PDF]. Available at: [\[https://www.benchchem.com/product/b11832995/docs#technical-guide-validation-of-crbn-binding-affinity-using-competition-assays\]](https://www.benchchem.com/product/b11832995/docs#technical-guide-validation-of-crbn-binding-affinity-using-competition-assays)

---

### Disclaimer & Data Validity:

The information provided in this document is for Research Use Only (RUO) and is strictly not intended for diagnostic or therapeutic procedures. While BenchChem strives to provide accurate protocols, we make no warranties, express or implied, regarding the fitness of this product for every specific experimental setup.

**Technical Support:** The protocols provided are for reference purposes. Unsure if this reagent suits your experiment?

**Need Industrial/Bulk Grade?** [Request Custom Synthesis Quote](#)

# BenchChem

Our mission is to be the trusted global source of essential and advanced chemicals, empowering scientists and researchers to drive progress in science and industry.

## Contact

Address: 3281 E Guasti Rd

Ontario, CA 91761, United States

Phone: (601) 213-4426

Email: [info@benchchem.com](mailto:info@benchchem.com)

[Contact our Ph.D. Support Team for a compatibility check](#)