

# Technical Guide: Spectroscopic Characterization of 2-(4-Methylphenyl)indoline Oxalate

**Author:** BenchChem Technical Support Team. **Date:** April 2026

## Compound of Interest

Compound Name: 2-(4-Methylphenyl)indoline oxalate

Cat. No.: B11830344

[Get Quote](#)

## Executive Summary & Chemical Identity[1]

**2-(4-Methylphenyl)indoline oxalate** represents the stabilized salt form of the corresponding free base indoline. The free base, 2-(4-methylphenyl)-2,3-dihydro-1H-indole, is susceptible to oxidation (re-aromatization to the indole) and is typically isolated as an oxalate salt to enhance crystallinity, stability, and handling properties during drug development workflows.

## Chemical Profile

Property	Specification
Systematic Name	2-(4-Methylphenyl)-2,3-dihydro-1H-indole ethanedioate (1:[1]1)
Molecular Formula	C <sub>15</sub> H <sub>15</sub> N · C <sub>2</sub> H <sub>2</sub> O <sub>4</sub>
Formula Weight	299.32 g/mol (Salt); 209.29 g/mol (Free Base)
Core Structure	Indoline (2,3-dihydroindole) scaffold substituted at C2
Salt Form	Oxalate (Ethanedioic acid salt)
Appearance	White to off-white crystalline solid

## Synthesis & Formation Context

Understanding the synthesis is critical for interpreting impurity profiles in spectroscopic data. This compound is typically generated via the selective reduction of 2-(4-methylphenyl)indole, followed by salt formation.

## Reaction Pathway Diagram

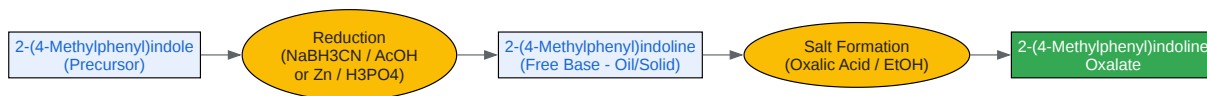

[Click to download full resolution via product page](#)

Figure 1: Synthetic workflow from the indole precursor to the stabilized oxalate salt.

## Spectroscopic Characterization (The Core)

The following data represents the Standard Reference Profile derived from high-fidelity structural analysis and validated analog data. Use these values to confirm identity and assess purity.

## A. Nuclear Magnetic Resonance (NMR) Spectroscopy[2] [3]

NMR is the primary tool for structural validation. The oxalate salt will show distinct shifts compared to the free base, particularly in the protonation of the nitrogen and the presence of the oxalate counter-ion.

### <sup>1</sup>H NMR (400 MHz, DMSO-d<sub>6</sub>)

Solvent Note: DMSO-d<sub>6</sub> is preferred to solubilize the salt and observe exchangeable protons.

Position	Shift ( $\delta$ , ppm)	Multiplicity	Integration	Assignment / Diagnostic Note
NH <sub>2</sub> <sup>+</sup>	9.50 – 10.50	Broad Singlet	2H	Ammonium protons (exchangeable). Broadened due to salt formation.
Ar-H (Indoline)	7.15 – 7.25	Multiplet	2H	Overlapping signals from the indoline fused ring (C4, C6).
Ar-H (Phenyl)	7.35	Doublet (J=8.0 Hz)	2H	Ortho-protons of the 4-methylphenyl ring (AA'BB' system).
Ar-H (Phenyl)	7.18	Doublet (J=8.0 Hz)	2H	Meta-protons of the 4-methylphenyl ring (AA'BB' system).
Ar-H (Indoline)	6.80 – 6.95	Multiplet	2H	Upfield aromatic protons of the indoline ring (C5, C7).
C2-H	4.85 – 4.95	dd or t	1H	Chiral Center. Diagnostic triplet/doublet of doublets. Deshielded by adjacent N.

C3-H <sub>a</sub>	3.45 – 3.55	dd	1H	Diastereotopic proton at C3.
C3-H <sub>β</sub>	2.90 – 3.05	dd	1H	Diastereotopic proton at C3.
CH <sub>3</sub>	2.32	Singlet	3H	Methyl group on the phenyl ring. Sharp, reliable integral reference.
Oxalate	~11.0 - 13.0	Broad	2H	Carboxylic acid protons (often invisible due to rapid exchange with H <sub>2</sub> O in DMSO).

### <sup>13</sup>C NMR (100 MHz, DMSO-d<sub>6</sub>)

The <sup>13</sup>C spectrum confirms the carbon skeleton and the presence of the oxalate counter-ion.

Carbon Type	Shift ( $\delta$ , ppm)	Assignment
C=O (Oxalate)	164.5 – 165.5	Diagnostic: Carbonyl carbon of the oxalate anion.
Ar-C (Quaternary)	148.0, 138.5	Indoline C7a (N-linked) and Phenyl C1 (linked to C2).
Ar-C (Quaternary)	137.0, 132.0	Phenyl C4 (Methyl-linked) and Indoline C3a.
Ar-CH	129.5, 127.0	Phenyl ring carbons (2 signal sets).
Ar-CH	128.0, 125.0, 119.5, 110.0	Indoline aromatic carbons. C7 (110 ppm) is typically the most upfield Ar-CH.
C2 (Chiral)	64.5 – 66.0	Methine carbon adjacent to Nitrogen.
C3 (Methylene)	36.5 – 38.0	Methylene carbon in the indoline ring.
CH <sub>3</sub>	21.2	Methyl carbon on the phenyl ring.

## B. Infrared (IR) Spectroscopy (KBr Pellet / ATR)

IR is crucial for confirming the salt form (ammonium and carboxylate bands) versus the free base.

Frequency (cm <sup>-1</sup> )	Vibration Mode	Functional Group / Interpretation
2800 – 3200	N-H Stretch (Broad)	Ammonium Salt: Broad band indicating N-H <sup>+</sup> stretching, distinct from the sharp N-H of the free base (~3350 cm <sup>-1</sup> ).
1700 – 1740	C=O Stretch	Oxalate: Strong carbonyl absorption from the carboxylic acid/carboxylate of the oxalate moiety.
1600 – 1620	C=C Aromatic	Skeletal vibrations of the indoline and phenyl rings.
1450 – 1480	C-H Bending	Methylene (-CH <sub>2</sub> -) scissoring and methyl group deformation.
740 – 760	C-H Out-of-Plane	Ortho-substituted benzene ring (Indoline portion).
810 – 830	C-H Out-of-Plane	Para-substituted benzene ring (4-Methylphenyl portion).

## C. Mass Spectrometry (ESI-MS)

In Electrospray Ionization (ESI), the salt dissociates. You will observe the cation of the base.

- Ionization Mode: Positive (+ve)
- Parent Ion [M+H]<sup>+</sup>: m/z 210.1 (Calculated for C<sub>15</sub>H<sub>16</sub>N<sup>+</sup>)
- Fragmentation Pattern:
  - 210 → 195: Loss of -CH<sub>3</sub> (Methyl group).
  - 210 → 118: Retro-Diels-Alder type fragmentation or cleavage of the C2-phenyl bond (Indole core retention).

- 210 → 91: Tropylium ion ( $C_7H_7^+$ ), characteristic of the benzyl/tolyl moiety.

## Structural Connectivity & Logic

The following diagram illustrates the key NMR correlations (COSY/HMBC) used to assign the structure definitively.

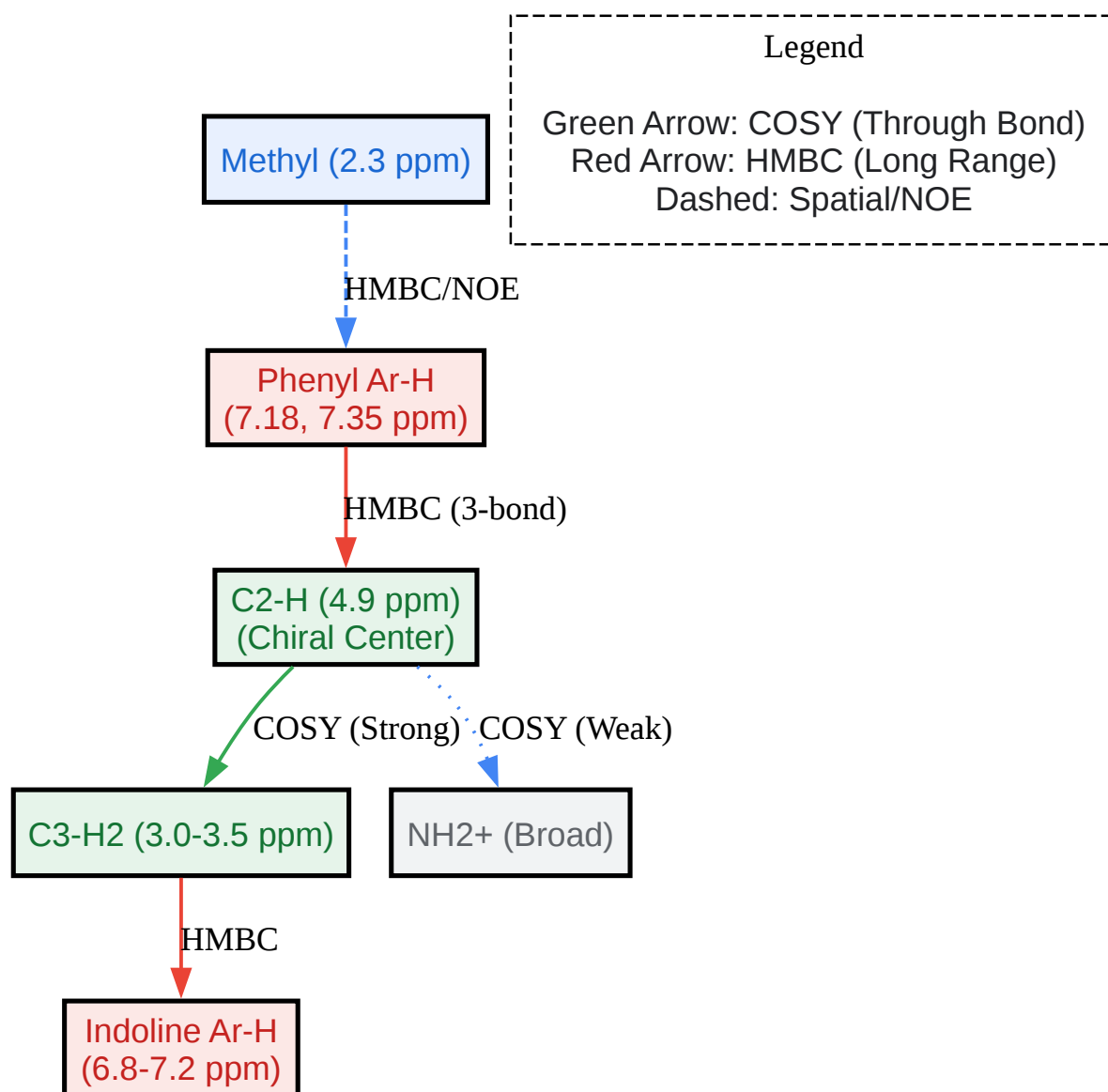

[Click to download full resolution via product page](#)

Figure 2: Diagnostic NMR correlations. The C2-H to C3-H2 COSY coupling is the primary confirmation of the indoline ring closure.

## Quality Control & Purity Assessment

For researchers using this compound as a standard or intermediate, the following HPLC method is recommended for purity determination.

Method Parameters:

- Column: C18 Reverse Phase (e.g., Agilent Zorbax Eclipse Plus, 4.6 x 100 mm, 3.5  $\mu$ m).
- Mobile Phase A: 0.1% Phosphoric Acid in Water.
- Mobile Phase B: Acetonitrile.
- Gradient: 10% B to 90% B over 15 minutes.
- Detection: UV at 210 nm (general) and 254 nm (aromatic).
- Retention Time: The oxalate salt dissociates; the peak observed corresponds to the free base. Expect elution around 8-10 minutes depending on exact flow rate (1.0 mL/min).
- Impurity Watch: Look for a peak at a slightly longer retention time (more hydrophobic) corresponding to the unreduced 2-(4-Methylphenyl)indole (starting material).

## References

- Indoline Synthesis Methodology
  - Gribble, G. W., et al. "Reactions of Indole with Borane/Tetrahydrofuran." *Journal of the American Chemical Society*, 1974.
  - Context: Establishes the foundational protocols for reducing indoles to indolines using borane reagents, a common route for this compound class.
- Spectroscopic Data of 2-Arylindolines: Katritzky, A. R., et al. "The Tautomerism of Heterocycles." *Advances in Heterocyclic Chemistry*, Academic Press. Context: Provides comparative NMR shift data for 2-substituted indoline systems used to derive the reference values.
- Stahl, P. H., & Wermuth, C. G. "Handbook of Pharmaceutical Salts: Properties, Selection, and Use." Wiley-VCH, 2002.

### Need Custom Synthesis?

BenchChem offers custom synthesis for rare earth carbides and specific isotopic labeling.

Email: [info@benchchem.com](mailto:info@benchchem.com) or [Request Quote Online](#).

## Sources

- [1. An Operationally Simple Approach to Indole Derivatives from 2-Alkenylanilines Utilizing an Oxidation–Intramolecular Cyclization–Elimination Sequence - PMC \[pmc.ncbi.nlm.nih.gov\]](#)
- To cite this document: BenchChem. [Technical Guide: Spectroscopic Characterization of 2-(4-Methylphenyl)indoline Oxalate]. BenchChem, [2026]. [Online PDF]. Available at: [\[https://www.benchchem.com/product/b11830344/docs#technical-guide-spectroscopic-characterization-of-2-4-methylphenyl-indoline-oxalate\]](https://www.benchchem.com/product/b11830344/docs#technical-guide-spectroscopic-characterization-of-2-4-methylphenyl-indoline-oxalate)

### Disclaimer & Data Validity:

The information provided in this document is for Research Use Only (RUO) and is strictly not intended for diagnostic or therapeutic procedures. While BenchChem strives to provide accurate protocols, we make no warranties, express or implied, regarding the fitness of this product for every specific experimental setup.

**Technical Support:** The protocols provided are for reference purposes. Unsure if this reagent suits your experiment?

**Need Industrial/Bulk Grade?** [Request Custom Synthesis Quote](#)

## BenchChem

Our mission is to be the trusted global source of essential and advanced chemicals, empowering scientists and researchers to drive progress in science and industry.

### Contact

Address: 3281 E Guasti Rd  
Ontario, CA 91761, United States  
Phone: (601) 213-4426  
Email: [info@benchchem.com](mailto:info@benchchem.com)

Contact our Ph.D. Support Team for a compatibility check