

Application Notes and Protocols for PC Biotin-PEG3-Azide in Click Chemistry

Author: BenchChem Technical Support Team. **Date:** April 2026

Compound of Interest

Compound Name: PC Biotin-PEG3-azide

Cat. No.: B11830298

[Get Quote](#)

For Researchers, Scientists, and Drug Development Professionals

Introduction

PC Biotin-PEG3-azide is a versatile chemical probe that integrates several key functionalities into a single molecule, making it a powerful tool for bioconjugation, proteomics, and drug delivery research.^[1] This reagent incorporates a photocleavable (PC) linker, a high-affinity biotin tag, a hydrophilic polyethylene glycol (PEG3) spacer, and a reactive azide group.^{[1][2]} The azide moiety allows for its covalent attachment to alkyne-containing molecules via "click chemistry," a set of biocompatible, highly efficient, and specific reactions.^{[3][4]} This document provides detailed protocols for utilizing **PC Biotin-PEG3-azide** in the two main types of azide-alkyne click chemistry: the Copper(I)-Catalyzed Azide-Alkyne Cycloaddition (CuAAC) and the Strain-Promoted Azide-Alkyne Cycloaddition (SPAAC).^{[1][4]} The photocleavable linker offers the unique advantage of allowing the release of the biotinylated molecule or its cargo under mild UV light exposure, enabling controlled release and recovery applications.^[1]

Key Features and Applications

The unique combination of functionalities in **PC Biotin-PEG3-azide** enables a wide range of applications in life sciences and drug development:

- Photo-Responsive Bioconjugation: Enables the controlled attachment and subsequent light-triggered release of biotinylated molecules from their targets.[1]
- Affinity Capture and Release: Facilitates the reversible immobilization and purification of alkyne-modified biomolecules on streptavidin-coated supports.[1]
- Probe Development: Serves as a building block for creating multifunctional probes for cellular imaging, proteomics, and diagnostic assays.[1][5]
- Chemical Biology: Supports orthogonal labeling strategies and provides spatiotemporal control over biological processes through light-induced cleavage.[1]
- Targeted Drug Delivery: The photocleavable linker can be exploited for the targeted release of therapeutic agents at specific sites upon light activation.[5]

Product Information

A summary of the key properties of **PC Biotin-PEG3-azide** is provided in the table below.

Property	Value	Reference
Chemical Name	PC Biotin-PEG3-azide	[2]
CAS Number	1937270-46-6	[2][6]
Molecular Formula	C35H55N9O12S	[2][6]
Molecular Weight	825.9 g/mol	[2][6]
Purity	≥95%	[1][2]
Storage Conditions	Store at -20°C, protected from light.	[1][2]

Experimental Protocols

PC Biotin-PEG3-azide can be conjugated to alkyne-containing molecules using either copper-catalyzed or strain-promoted click chemistry. The choice of method depends on the specific application, particularly the sensitivity of the biological system to copper.

Protocol 1: Copper(I)-Catalyzed Azide-Alkyne Cycloaddition (CuAAC)

The CuAAC reaction is a highly efficient and widely used click chemistry method that utilizes a copper(I) catalyst to join azides and terminal alkynes.^{[3][7][8]} This protocol is suitable for in vitro applications with purified biomolecules.

Materials:

- **PC Biotin-PEG3-azide**
- Alkyne-containing molecule (e.g., protein, nucleic acid, small molecule)
- Copper(II) Sulfate (CuSO₄)
- Sodium Ascorbate
- Tris(3-hydroxypropyltriazolylmethyl)amine (THPTA) or Tris((1-benzyl-1H-1,2,3-triazol-4-yl)methyl)amine (TBTA) as a copper ligand
- Reaction Buffer (e.g., phosphate-buffered saline (PBS), pH 7.4)
- Solvent for dissolving reagents (e.g., DMSO, DMF)

Reaction Parameters:

Reagent	Final Concentration (Suggested)	Notes
Alkyne-Molecule	1-100 μ M	The concentration will depend on the specific molecule and application.
PC Biotin-PEG3-azide	1.5 - 10 equivalents (to alkyne)	An excess of the azide is typically used to ensure complete reaction with the alkyne.
CuSO ₄	50-100 μ M	
THPTA/TBTA	250-500 μ M	A 5:1 molar ratio of ligand to CuSO ₄ is recommended to stabilize the Cu(I) ion.[7]
Sodium Ascorbate	1-5 mM	A fresh solution should be prepared. This is added to reduce Cu(II) to the active Cu(I) catalyst.[7][9]

Procedure:

- Prepare Stock Solutions:
 - Dissolve **PC Biotin-PEG3-azide** in DMSO or an appropriate solvent to a stock concentration of 10-50 mM.
 - Prepare a stock solution of your alkyne-containing molecule in a compatible buffer.
 - Prepare stock solutions of CuSO₄ (10-100 mM in water), THPTA/TBTA (50-500 mM in water or DMSO), and Sodium Ascorbate (100 mM in water). Prepare the sodium ascorbate solution fresh before each experiment.
- Reaction Setup:

- In a microcentrifuge tube, add the alkyne-containing molecule to the desired final concentration in the reaction buffer.
- Add the **PC Biotin-PEG3-azide** stock solution to the desired final concentration.
- Add the THPTA/TBTA ligand to the reaction mixture.
- Add the CuSO₄ stock solution.
- Vortex the mixture gently.
- Initiate the Reaction:
 - Add the freshly prepared sodium ascorbate solution to the reaction mixture to initiate the click reaction.
 - Vortex the mixture gently to ensure homogeneity.
- Incubation:
 - Incubate the reaction at room temperature for 1-4 hours. The reaction time may need to be optimized depending on the specific reactants. Protect the reaction from light.
- Purification:
 - Purify the biotinylated product from excess reagents using an appropriate method such as dialysis, size-exclusion chromatography, or affinity chromatography.

Protocol 2: Strain-Promoted Azide-Alkyne Cycloaddition (SPAAC)

SPAAC is a copper-free click chemistry method that is ideal for applications in living cells or other biological systems where the cytotoxicity of copper is a concern.^{[10][11]} This reaction utilizes a strained cyclooctyne, such as dibenzocyclooctyne (DBCO) or bicyclononyne (BCN), which reacts spontaneously with azides.^{[10][12]}

Materials:

- **PC Biotin-PEG3-azide**
- Cyclooctyne-containing molecule (e.g., DBCO- or BCN-modified protein)
- Reaction Buffer (e.g., PBS, pH 7.4, or cell culture medium)
- Solvent for dissolving **PC Biotin-PEG3-azide** (e.g., DMSO)

Reaction Parameters:

Reagent	Final Concentration (Suggested)	Notes
Cyclooctyne-Molecule	1-100 μ M (in vitro) or 10-100 μ M (in cellulo)	The concentration will vary depending on the experimental setup.
PC Biotin-PEG3-azide	1.5 - 10 equivalents (to cyclooctyne)	An excess of the azide is generally used to drive the reaction to completion.

Procedure:

- Prepare Stock Solutions:
 - Dissolve **PC Biotin-PEG3-azide** in DMSO to a stock concentration of 10-50 mM.
 - Prepare a stock solution of your cyclooctyne-containing molecule in a compatible buffer or medium.
- Reaction Setup:
 - For in vitro reactions: In a microcentrifuge tube, add the cyclooctyne-containing molecule to the desired final concentration in the reaction buffer.
 - For labeling in live cells: Add the **PC Biotin-PEG3-azide** stock solution directly to the cell culture medium containing the cells that have been metabolically labeled with a cyclooctyne-modified substrate.

- Initiate the Reaction:
 - Add the **PC Biotin-PEG3-azide** stock solution to the reaction mixture or cell culture medium.
 - Mix gently.
- Incubation:
 - Incubate the reaction at room temperature or 37°C (for live cells) for 1-12 hours. The reaction time will depend on the reactivity of the specific cyclooctyne and the concentration of the reactants.
- Washing and Analysis (for live cells):
 - After incubation, wash the cells with fresh buffer or medium to remove unreacted **PC Biotin-PEG3-azide**.
 - The biotinylated cells or biomolecules can then be analyzed by methods such as flow cytometry, fluorescence microscopy (after staining with a fluorescent streptavidin conjugate), or Western blotting.

Visualization of Workflows

The following diagrams illustrate the chemical principle of the click reactions and a typical experimental workflow for affinity capture and release.

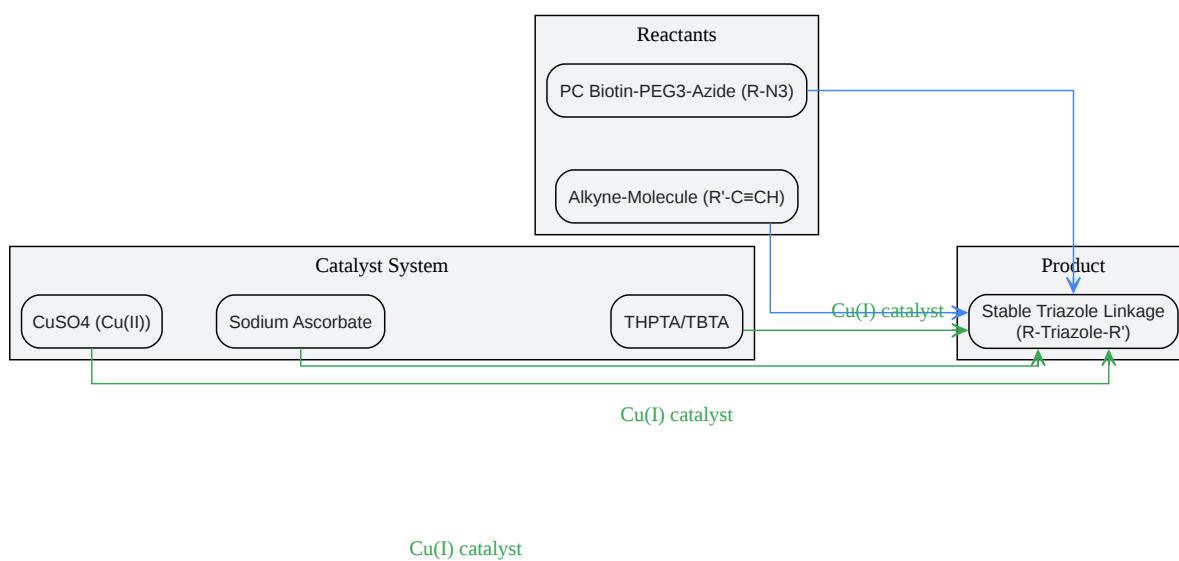

[Click to download full resolution via product page](#)

Caption: Copper(I)-Catalyzed Azide-Alkyne Cycloaddition (CuAAC) Reaction Scheme.

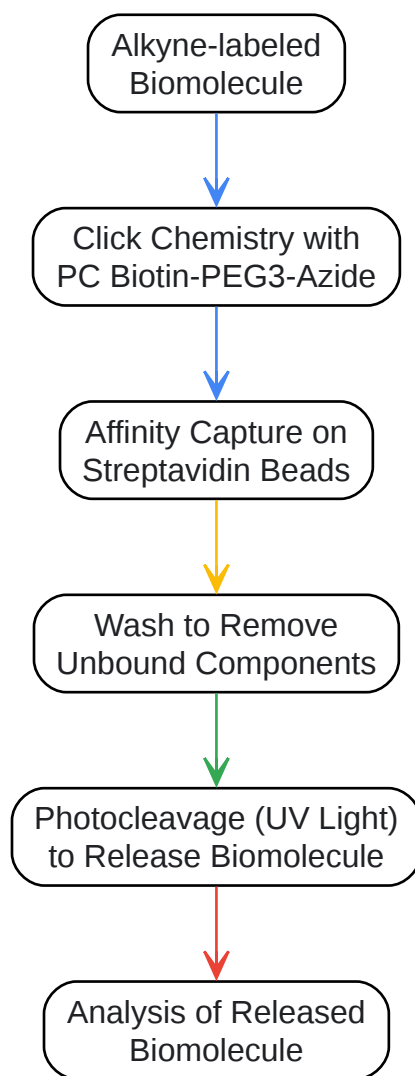
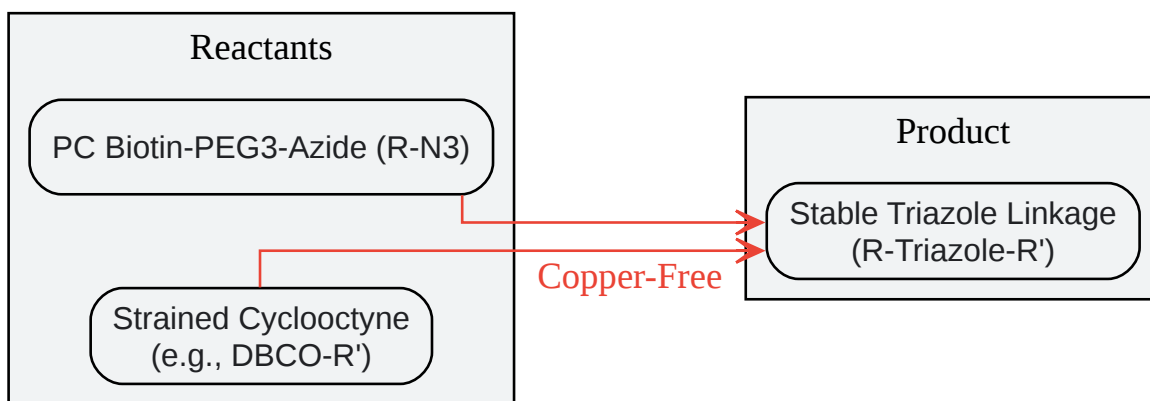

[Click to download full resolution via product page](#)

Need Custom Synthesis?

BenchChem offers custom synthesis for rare earth carbides and specific isotopic labeling.

Email: info@benchchem.com or [Request Quote Online](#).

References

- 1. PC Biotin-PEG3-azide, CAS 1937270-46-6 | AxisPharm [axispharm.com]
- 2. PC Biotin-PEG3-azide, 1937270-46-6 | BroadPharm [broadpharm.com]
- 3. bioconjugation.bocsci.com [bioconjugation.bocsci.com]
- 4. medchemexpress.com [medchemexpress.com]
- 5. PC-Biotin-PEG4-PEG3-azide, CAS 2055198-04-2 | AxisPharm [axispharm.com]
- 6. precisepeg.com [precisepeg.com]
- 7. broadpharm.com [broadpharm.com]
- 8. Click Chemistry [organic-chemistry.org]
- 9. axispharm.com [axispharm.com]
- 10. bioconjugation.bocsci.com [bioconjugation.bocsci.com]
- 11. Strain-Promoted Azide-Alkyne Cycloaddition [manu56.magtech.com.cn]
- 12. PC Biotin-PEG3-azide - CD Bioparticles [cd-bioparticles.net]
- To cite this document: BenchChem. [Application Notes and Protocols for PC Biotin-PEG3-Azide in Click Chemistry]. BenchChem, [2026]. [Online PDF]. Available at: [<https://www.benchchem.com/product/b11830298/docs#application-notes-and-protocols-for-pc-biotin-peg3-azide-in-click-chemistry>]

Disclaimer & Data Validity:

The information provided in this document is for Research Use Only (RUO) and is strictly not intended for diagnostic or therapeutic procedures. While BenchChem strives to provide accurate protocols, we make no warranties, express or implied, regarding the fitness of this product for every specific experimental setup.

Technical Support: The protocols provided are for reference purposes. Unsure if this reagent suits your experiment?

Need Industrial/Bulk Grade? [Request Custom Synthesis Quote](#)

BenchChem

Our mission is to be the trusted global source of essential and advanced chemicals, empowering scientists and researchers to drive progress in science and industry.

Contact

Address: 3281 E Guasti Rd
Ontario, CA 91761, United States
Phone: (601) 213-4426
Email: info@benchchem.com

[Contact our Ph.D. Support Team for a compatibility check](#)