

A Comparative Guide to Lacto-N-fucopentaose I (LNFP I) Quantification Methods

Author: BenchChem Technical Support Team. **Date:** April 2026

Compound of Interest

Compound Name: *Lnfp I*
Cat. No.: *B11829438*

[Get Quote](#)

For Researchers, Scientists, and Drug Development Professionals

This guide provides a detailed comparison of the primary analytical methods for the quantification of Lacto-N-fucopentaose I (**LNFP I**), a key human milk oligosaccharide (HMO). We will delve into the experimental protocols, present comparative performance data, and illustrate relevant biological pathways to aid researchers in selecting the most suitable method for their specific needs.

Introduction to LNFP I and its Quantification

Lacto-N-fucopentaose I (**LNFP I**) is a prominent fucosylated neutral oligosaccharide in human milk, playing a significant role in infant health. Its biological activities, including antiviral and antibacterial effects, are of growing interest in the fields of nutrition and drug development.^{[1][2][3]} Accurate and precise quantification of **LNFP I** is crucial for research, quality control of infant formula, and the development of **LNFP I**-based therapeutics. The primary methods for **LNFP I** quantification are High-Performance Anion-Exchange Chromatography with Pulsed Amperometric Detection (HPAEC-PAD), Liquid Chromatography-Mass Spectrometry (LC-MS), and Nuclear Magnetic Resonance (NMR) spectroscopy.

Comparison of Quantification Methods

The choice of quantification method depends on various factors, including the required sensitivity, selectivity, throughput, and the available instrumentation. Below is a summary of the key performance characteristics of HPAEC-PAD, LC-MS, and NMR for **LNFP I** quantification.

Quantitative Performance Data

Parameter	HPAEC-PAD	LC-MS	qNMR
Linearity (R ²)	>0.99	>0.99	Essentially linear
Limit of Quantification (LOQ)	0.12–2.3 mg/L (for FOS)	0.0054–0.0063 µg/mL (for some HMOs)	Higher than LC-MS and HPAEC-PAD
Accuracy (% Recovery)	Not explicitly found for LNFP I	79.5–110.9% (for some HMOs)	98.8% to 100%
Precision (%RSD)	<15% (general requirement)	≤ 12.7% (for some HMOs)	0.33% to 0.46%
Throughput	Moderate	High	Low to Moderate
Selectivity	Good for isomers	Excellent for isomers (with appropriate chromatography)	Excellent for structural elucidation
Matrix Effect	Can be significant	Can be significant, requires mitigation	Minimal

Experimental Protocols

Detailed methodologies are essential for reproducing and comparing results across different studies. Here are summaries of typical experimental protocols for each quantification method.

High-Performance Anion-Exchange Chromatography with Pulsed Amperometric Detection (HPAEC-PAD)

HPAEC-PAD is a robust and sensitive method for the analysis of carbohydrates, including neutral and acidic oligosaccharides.[\[4\]](#)[\[5\]](#)[\[6\]](#)

Sample Preparation:

- Dilution of the sample (e.g., human milk, infant formula) with deionized water.
- Removal of proteins and lipids by centrifugation and filtration.
- For complex matrices, solid-phase extraction (SPE) may be used for cleanup.

Chromatographic Conditions:

- Column: A high-pH anion-exchange column, such as a Dionex CarboPac series column.
- Mobile Phase: A gradient of sodium hydroxide and sodium acetate.
- Detection: Pulsed Amperometric Detection (PAD) with a gold working electrode.

Quantification: Quantification is achieved by comparing the peak area of **LNFP I** in the sample to a calibration curve generated from certified reference standards.

Liquid Chromatography-Mass Spectrometry (LC-MS)

LC-MS offers high sensitivity and selectivity, making it a powerful tool for the quantification of HMOs in complex biological matrices.

Sample Preparation:

- Similar to HPAEC-PAD, samples are typically deproteinized and delipidated.
- Derivatization with a fluorescent tag is sometimes employed to improve chromatographic separation and sensitivity, though direct analysis is also common.

Chromatographic Conditions:

- Column: Porous graphitized carbon (PGC) or hydrophilic interaction liquid chromatography (HILIC) columns are commonly used to separate HMO isomers.
- Mobile Phase: A gradient of acetonitrile and water with additives like ammonium formate or formic acid.

Mass Spectrometry Conditions:

- Ionization: Electrospray ionization (ESI) in negative or positive mode.
- Detection: Selected Ion Monitoring (SIM) or Multiple Reaction Monitoring (MRM) for targeted quantification.

Quantification: Absolute quantification is performed using an external calibration curve with isotopically labeled internal standards to correct for matrix effects and variations in instrument response.

Quantitative Nuclear Magnetic Resonance (qNMR) Spectroscopy

qNMR is a primary analytical method that allows for the direct quantification of analytes without the need for identical reference standards for calibration.[7][8]

Sample Preparation:

- Lyophilization of the sample.
- Reconstitution in a deuterated solvent (e.g., D₂O) containing an internal standard with a known concentration.

NMR Spectroscopy:

- Instrument: A high-field NMR spectrometer (e.g., 400 MHz or higher).
- Experiment: A one-dimensional proton (¹H) NMR spectrum is acquired with appropriate parameters to ensure full relaxation of the signals.

Quantification: The concentration of **LNFP I** is calculated by comparing the integral of a specific, well-resolved **LNFP I** proton signal to the integral of a known signal from the internal standard. The PULCON (Pulse Length-based Concentration determination) method can also be used for external calibration.[9]

Biological Role and Signaling Pathway of LNFP I

LNFP I exhibits significant biological activities, including antiviral and antibacterial effects, and plays a role in modulating the infant gut microbiota.[1][10]

Antiviral Activity of LNFP I

LNFP I has been shown to inhibit the infection of enterovirus 71 (EV71).[2] Its proposed mechanism involves blocking virus adsorption by reducing the viral capsid protein VP1. Furthermore, **LNFP I** can counteract the virus-induced S-phase arrest in the cell cycle by promoting the expression of cyclin-dependent kinase 2 (CDK2) and reducing the expression of cyclin E.[1][2] It also exhibits anti-apoptotic effects by inhibiting the expression of key apoptosis-related genes such as Egl-1, Ced-3, and Ced-4.[1]

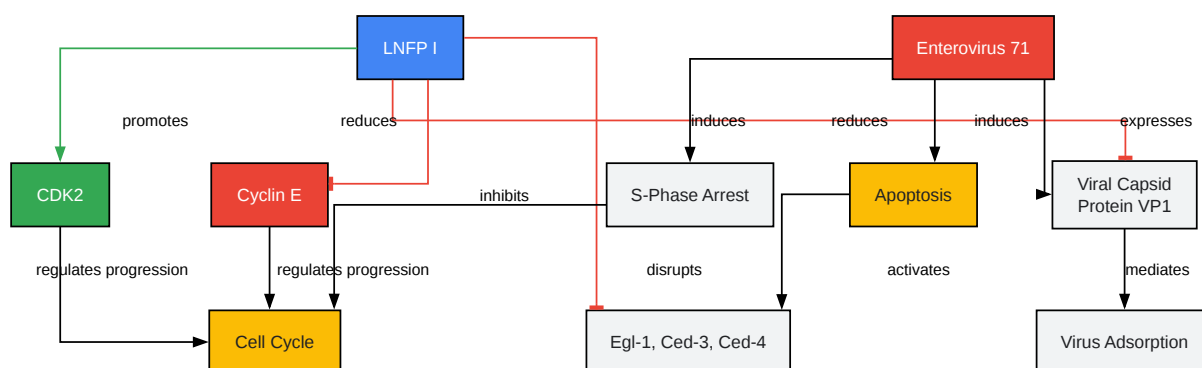

[Click to download full resolution via product page](#)

Caption: Antiviral signaling pathway of **LNFP I** against Enterovirus 71.

Gut Microbiota Modulation

LNFP I can influence the composition of the gut microbiota, which in turn communicates with distant organs through microbial metabolites, affecting the host's immune system, metabolism, and even brain function.[1][11] Probiotics and commensal bacteria modulate key signaling pathways such as NF- κ B and MAPK in intestinal epithelial cells, macrophages, and dendritic cells, thereby regulating cytokine secretion and immune responses.[12] **LNFP I** can selectively promote the growth of beneficial bacteria like *Bifidobacterium infantis*, which can outcompete pathogenic bacteria.[10]

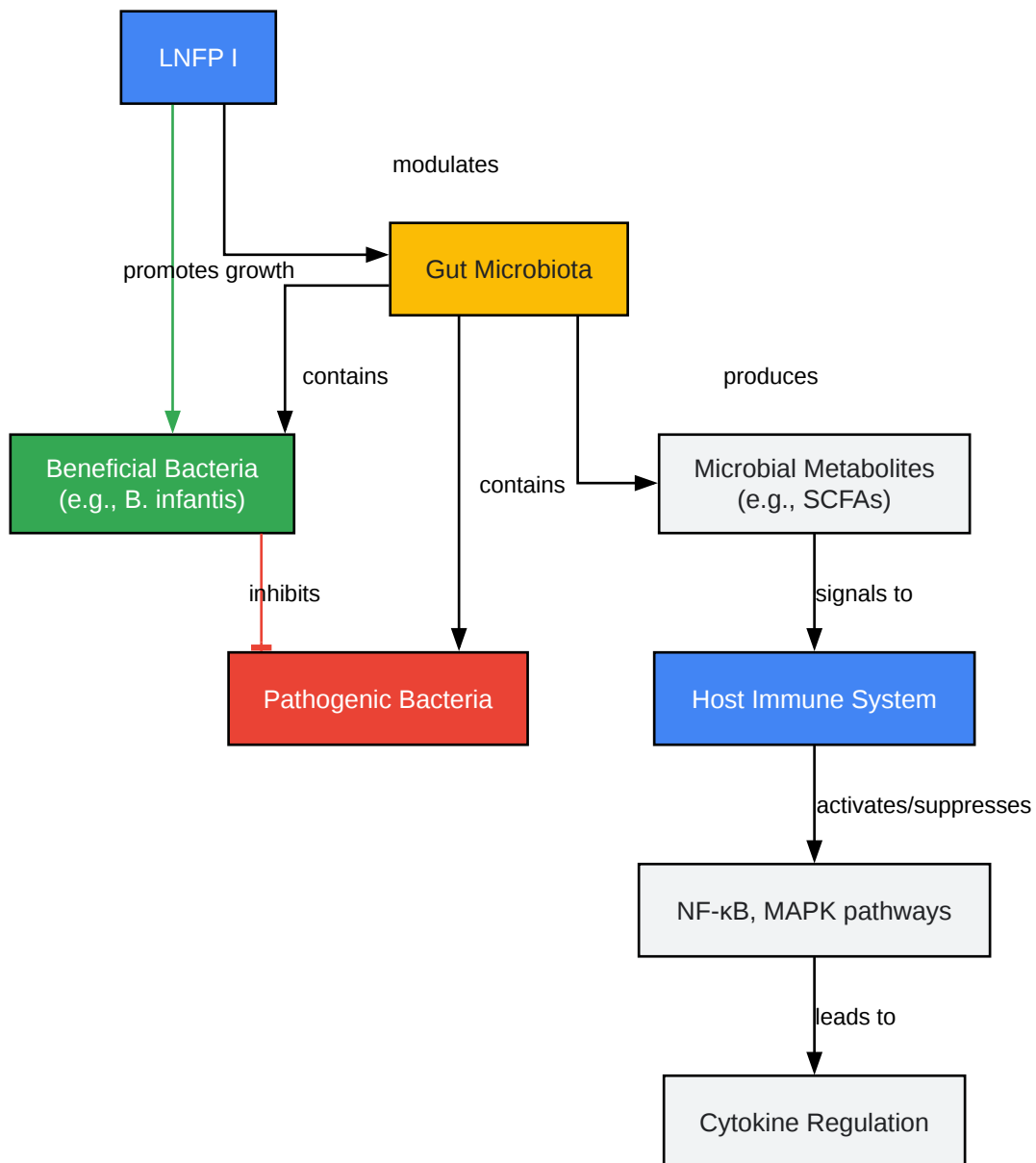

[Click to download full resolution via product page](#)

Caption: Modulation of gut microbiota and host signaling by **LNFP I**.

Experimental Workflow for Cross-Validation

A robust cross-validation of these methods would involve analyzing the same set of samples with each technique and comparing the quantitative results.

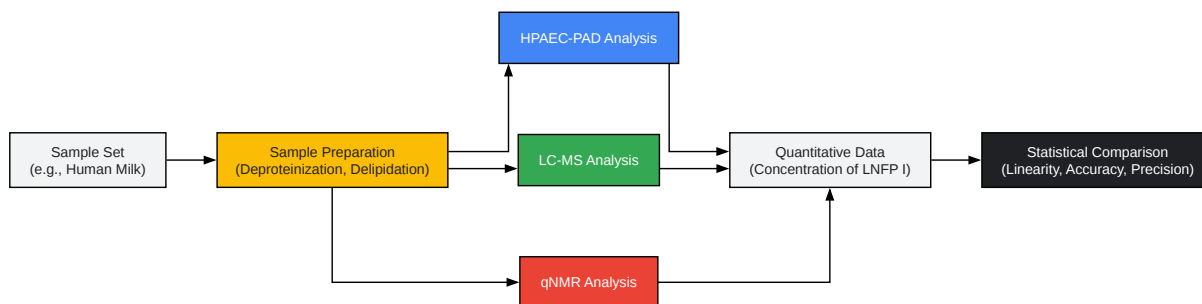

[Click to download full resolution via product page](#)

Caption: Experimental workflow for cross-validation of **LNFP I** quantification methods.

Conclusion

The quantification of **LNFP I** can be reliably achieved using HPAEC-PAD, LC-MS, and qNMR. LC-MS generally offers the highest sensitivity and throughput, making it suitable for large-scale studies. HPAEC-PAD is a robust and sensitive alternative, particularly in laboratories without access to mass spectrometry. qNMR provides excellent accuracy and precision and serves as a primary reference method, although with lower throughput and sensitivity compared to the other techniques. The selection of the most appropriate method will depend on the specific research question, sample matrix, and available resources. A thorough understanding of the advantages and limitations of each technique, as outlined in this guide, is essential for obtaining accurate and reliable quantification of **LNFP I**.

Need Custom Synthesis?

BenchChem offers custom synthesis for rare earth carbides and specific isotopic labeling.

Email: info@benchchem.com or [Request Quote Online](#).

References

- 1. [medchemexpress.com](https://www.medchemexpress.com) [[medchemexpress.com](https://www.medchemexpress.com)]
- 2. Fucosylated oligosaccharide Lacto-N-fucopentaose I ameliorates enterovirus 71 infection by inhibiting apoptosis - PMC [[pmc.ncbi.nlm.nih.gov](https://pubmed.ncbi.nlm.nih.gov)]
- 3. Selective microbial production of lacto-N-fucopentaose I in Escherichia coli using engineered α -1,2-fucosyltransferases - PubMed [pubmed.ncbi.nlm.nih.gov]
- 4. High-Performance Anion-Exchange Chromatography with Pulsed Amperometric Detection (HPAEC-PAD) - Creative Biolabs [[creative-biolabs.com](https://www.creative-biolabs.com)]
- 5. [researchgate.net](https://www.researchgate.net) [[researchgate.net](https://www.researchgate.net)]
- 6. High-performance anion-exchange chromatography with pulsed amperometric detection for carbohydrate analysis of glycoproteins - PubMed [pubmed.ncbi.nlm.nih.gov]
- 7. [agilent.com](https://www.agilent.com) [[agilent.com](https://www.agilent.com)]
- 8. Application of quantitative NMR in pharmaceutical analysis: Method qualification and potency determination for two new chemical entities in early-stage clinical studies - PubMed [pubmed.ncbi.nlm.nih.gov]
- 9. [frontiersin.org](https://www.frontiersin.org) [[frontiersin.org](https://www.frontiersin.org)]
- 10. WO2024223918A1 - Lacto-n-fucopentaose and b. infantis to protect from enteric pathogens - Google Patents [patents.google.com]
- 11. [natap.org](https://www.natap.org) [[natap.org](https://www.natap.org)]
- 12. Probiotics-host communication: Modulation of signaling pathways in the intestine - PMC [[pmc.ncbi.nlm.nih.gov](https://pubmed.ncbi.nlm.nih.gov)]
- To cite this document: BenchChem. [A Comparative Guide to Lacto-N-fucopentaose I (LNFP I) Quantification Methods]. BenchChem, [2026]. [Online PDF]. Available at: [<https://www.benchchem.com/product/b11829438/docs#a-comparative-guide-to-lacto-n-fucopentaose-i-lnfp-i-quantification-methods>]

Disclaimer & Data Validity:

The information provided in this document is for Research Use Only (RUO) and is strictly not intended for diagnostic or therapeutic procedures. While BenchChem strives to provide accurate protocols, we make no warranties, express or implied, regarding the fitness of this product for every specific experimental setup.

Technical Support: The protocols provided are for reference purposes. Unsure if this reagent suits your experiment?

Need Industrial/Bulk Grade? [Request Custom Synthesis Quote](#)

BenchChem

Our mission is to be the trusted global source of essential and advanced chemicals, empowering scientists and researchers to drive progress in science and industry.

Contact

Address: 3281 E Guasti Rd
Ontario, CA 91761, United States
Phone: (601) 213-4426
Email: info@benchchem.com

[Contact our Ph.D. Support Team for a compatibility check](#)