

Synthesis of liquid crystal intermediates from arylalkynes

Author: BenchChem Technical Support Team. **Date:** May 2026

Compound of Interest

Compound Name: *1-Hexyl-2-(4-bromophenyl)acetylene*

Cat. No.: *B11826730*

[Get Quote](#)

Application Notes & Protocols

Topic: Synthesis of Liquid Crystal Intermediates from Arylalkynes

Audience: Researchers, scientists, and drug development professionals.

Introduction: The Architectural Significance of Arylalkynes in Liquid Crystal Design

Calamitic, or rod-like, liquid crystals are materials defined by their molecular shape anisotropy—a rigid, elongated core structure appended with flexible terminal chains.^{[1][2][3]} This architecture is fundamental to the formation of the mesophases that underpin their utility in display technologies and advanced materials. Within the diverse library of molecular scaffolds used to construct these rigid cores, arylalkynes, and particularly the diphenylacetylene (tolan) framework, hold a privileged position.^{[4][5]}

The triple bond of the alkyne imparts a near-perfect linear geometry, which is crucial for maintaining the high aspect ratio required for liquid crystalline behavior. This linearity, combined

with a highly polarizable π -electron system, contributes to the strong intermolecular anisotropic dispersion forces that stabilize the liquid crystal phase. The synthesis of these vital intermediates is predominantly achieved through palladium-catalyzed cross-coupling reactions, which provide a powerful and versatile methodology for forming the key C(sp²)-C(sp) bonds.[6][7][8] Among these, the Sonogashira coupling stands out as the most direct and efficient route for linking aryl halides with terminal alkynes.[9][10][11]

This guide provides a detailed examination of the synthesis of tolan-based liquid crystal intermediates, focusing on the mechanistic principles, practical execution, and rigorous characterization required to ensure success.

Core Synthetic Methodology: The Sonogashira Cross-Coupling Reaction

The Sonogashira reaction is a cornerstone of modern organic synthesis, enabling the formation of a carbon-carbon bond between a terminal alkyne and an aryl or vinyl halide.[9][10] The reaction is co-catalyzed by palladium and copper complexes and proceeds under mild conditions, making it exceptionally valuable for the synthesis of complex molecules like liquid crystal precursors.[10][11]

Mechanistic Principles: A Dual Catalytic Cycle

The reaction mechanism is understood to operate through two interconnected catalytic cycles: a primary palladium cycle and a secondary copper cycle.[12][13] This dual system works in concert to activate both the aryl halide and the alkyne for the final coupling step.

- The Palladium Cycle (The Cross-Coupling Engine):
 - Oxidative Addition: The cycle begins with a 14-electron Pd(0) complex, which undergoes oxidative addition with the aryl halide (Ar-X). This step forms a square planar Pd(II) intermediate, activating the aryl group.[10]
 - Transmetalation: The activated aryl group is then transferred from a copper acetylide (generated in the copper cycle) to the palladium center. This step displaces the halide and forms a new Pd(II)-alkynyl-aryl complex.[13]

- Reductive Elimination: This is the final bond-forming step. The coupled arylalkyne product is expelled from the palladium center, which is simultaneously reduced from Pd(II) back to the catalytically active Pd(0) state, allowing the cycle to begin anew.
- The Copper Cycle (The Alkyne Activator):
 - π -Alkyne Complex Formation: The Cu(I) salt (typically CuI) coordinates with the terminal alkyne. This interaction increases the acidity of the terminal alkyne's proton.[13]
 - Deprotonation: An amine base (e.g., triethylamine) deprotonates the acidic alkyne, leading to the formation of a highly reactive copper acetylide intermediate.[12][13] This species is now primed for the transmetalation step with the palladium complex.

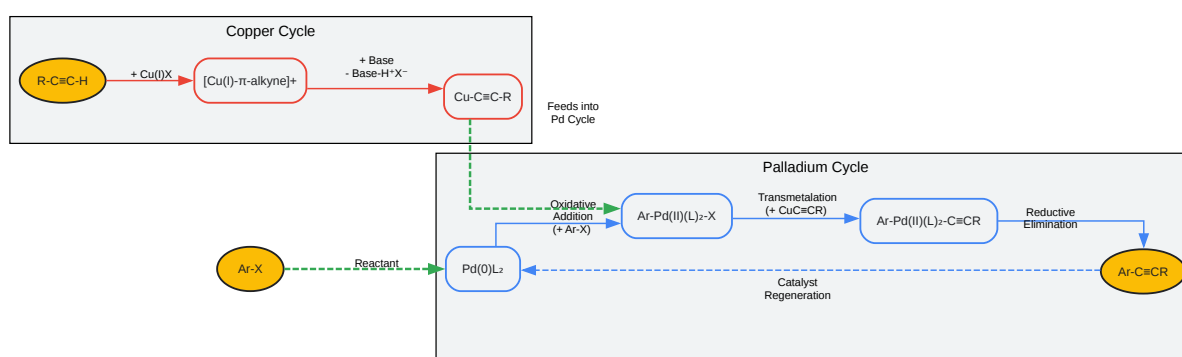

[Click to download full resolution via product page](#)

Caption: The dual catalytic cycle mechanism of the Sonogashira cross-coupling reaction.

Causality Behind Experimental Choices

A successful Sonogashira coupling relies on the careful selection of reagents and conditions.

- Choice of Aryl Halide: The reactivity of the aryl halide (Ar-X) is paramount and follows the trend $I > Br > OTf \gg Cl$.^[9] Aryl iodides are the most reactive and often allow for reactions to proceed at room temperature.^[10] Aryl bromides are also common substrates but typically require elevated temperatures to achieve reasonable reaction rates.
- Catalyst System:
 - Palladium Source: Both Pd(0) complexes like $Pd(PPh_3)_4$ and Pd(II) pre-catalysts such as $PdCl_2(PPh_3)_2$ are effective. Pd(II) sources are often more stable to air and are reduced in situ to the active Pd(0) species under the reaction conditions.^{[10][14]}
 - Copper(I) Co-catalyst: Copper(I) iodide (CuI) is the most common co-catalyst. Its primary role is to facilitate the deprotonation of the alkyne by forming the copper acetylide. However, a significant drawback is the potential for oxidative homocoupling of the alkyne (Glaser coupling) to form diynes, especially in the presence of oxygen.^{[9][10]} This necessitates the use of an inert, anaerobic atmosphere (N_2 or Ar).
- Base and Solvent: An amine base, such as triethylamine (TEA) or diisopropylamine (DIPA), serves a dual purpose. It neutralizes the hydrogen halide (HX) produced during the reaction and can also serve as the solvent.^[11] Using the base as a solvent ensures a high concentration, which can accelerate the reaction.

Experimental Protocol: Synthesis of 4-methoxy-4'-pentyltolane

This protocol details the synthesis of a representative tolan-based liquid crystal intermediate. The procedure is designed to be self-validating through rigorous purification and characterization steps.

Reaction Scheme: 4-iodoanisole + 1-pentyne \rightarrow 4-methoxy-4'-pentyltolane

Materials and Equipment

- Reactants: 4-iodoanisole, 1-pentyne
- Catalysts: Dichlorobis(triphenylphosphine)palladium(II) [$PdCl_2(PPh_3)_2$], Copper(I) iodide [CuI]

- Solvent/Base: Triethylamine (TEA), anhydrous
- Work-up: Diethyl ether, 1M HCl, Saturated NaCl (brine), Anhydrous MgSO₄
- Purification: Silica gel (for column chromatography), Hexane, Dichloromethane
- Equipment: Schlenk flask, magnetic stirrer, heating mantle, condenser, nitrogen/argon line, rotary evaporator, chromatography column.

Step-by-Step Methodology

- Inert Atmosphere Setup: Assemble a 100 mL Schlenk flask equipped with a magnetic stir bar and condenser. Flame-dry the glassware under vacuum and backfill with dry nitrogen or argon. Maintain a positive pressure of inert gas throughout the reaction.
- Reagent Addition:
 - To the flask, add 4-iodoanisole (e.g., 2.34 g, 10 mmol, 1.0 equiv.).
 - Add anhydrous triethylamine (50 mL). Stir the mixture until the solid dissolves.
 - Add 1-pentyne (e.g., 1.02 g, 15 mmol, 1.5 equiv.) via syringe. Rationale: A slight excess of the alkyne is used to ensure complete consumption of the more valuable aryl iodide.
 - Degas the solution by bubbling nitrogen through it for 15-20 minutes. Rationale: This step is critical to remove dissolved oxygen, which promotes the undesirable homocoupling of the alkyne.
- Catalyst Addition:
 - Under a positive flow of nitrogen, add CuI (e.g., 38 mg, 0.2 mmol, 2 mol%).
 - Add PdCl₂(PPh₃)₂ (e.g., 70 mg, 0.1 mmol, 1 mol%). Rationale: The catalysts are added last to the deoxygenated mixture to maximize their lifetime and activity.
- Reaction Execution:

- Stir the reaction mixture at room temperature. The mixture will typically turn from a pale yellow to a darker brown/black suspension.
- Monitor the reaction progress using Thin Layer Chromatography (TLC) (e.g., 10% ethyl acetate in hexanes). The reaction is complete when the 4-iodoanisole spot is no longer visible (typically 4-6 hours).
- Work-up and Extraction:
 - Once complete, cool the mixture to room temperature and filter it through a pad of Celite to remove the catalyst residues and amine salts. Wash the pad with diethyl ether.
 - Combine the filtrates and concentrate under reduced pressure using a rotary evaporator.
 - Redissolve the crude residue in diethyl ether (100 mL) and transfer to a separatory funnel.
 - Wash the organic layer sequentially with 1M HCl (2 x 50 mL) to remove excess TEA, followed by saturated NaCl solution (1 x 50 mL).
 - Dry the organic layer over anhydrous $MgSO_4$, filter, and concentrate in vacuo to yield the crude product.
- Purification:
 - Column Chromatography: Purify the crude oil on a silica gel column, eluting with a gradient of hexane to 2% dichloromethane in hexane. Rationale: This step removes unreacted starting materials, homocoupled alkyne, and other nonpolar impurities.
 - Recrystallization: If the product solidifies, it can be further purified by recrystallization from a suitable solvent like ethanol or methanol to achieve high purity.[\[15\]](#)

Data Summary Table

Parameter	Value	Rationale
Aryl Halide	4-iodoanisole (1.0 equiv.)	High reactivity allows for mild reaction conditions.
Alkyne	1-pentyne (1.5 equiv.)	Excess drives reaction to completion.
Pd Catalyst	$\text{PdCl}_2(\text{PPh}_3)_2$ (1 mol%)	Standard, effective pre-catalyst.
Cu Co-catalyst	CuI (2 mol%)	Activates the alkyne for transmetalation.
Base/Solvent	Triethylamine	Neutralizes HX byproduct and serves as solvent.
Temperature	Room Temperature	Sufficient for reactive aryl iodides.
Atmosphere	Anhydrous Nitrogen	Prevents oxidative homocoupling of the alkyne.
Typical Yield	85-95%	

Characterization and Validation Workflow

Confirming the identity, purity, and liquid crystalline properties of the synthesized intermediate is a critical final step.[\[16\]](#)

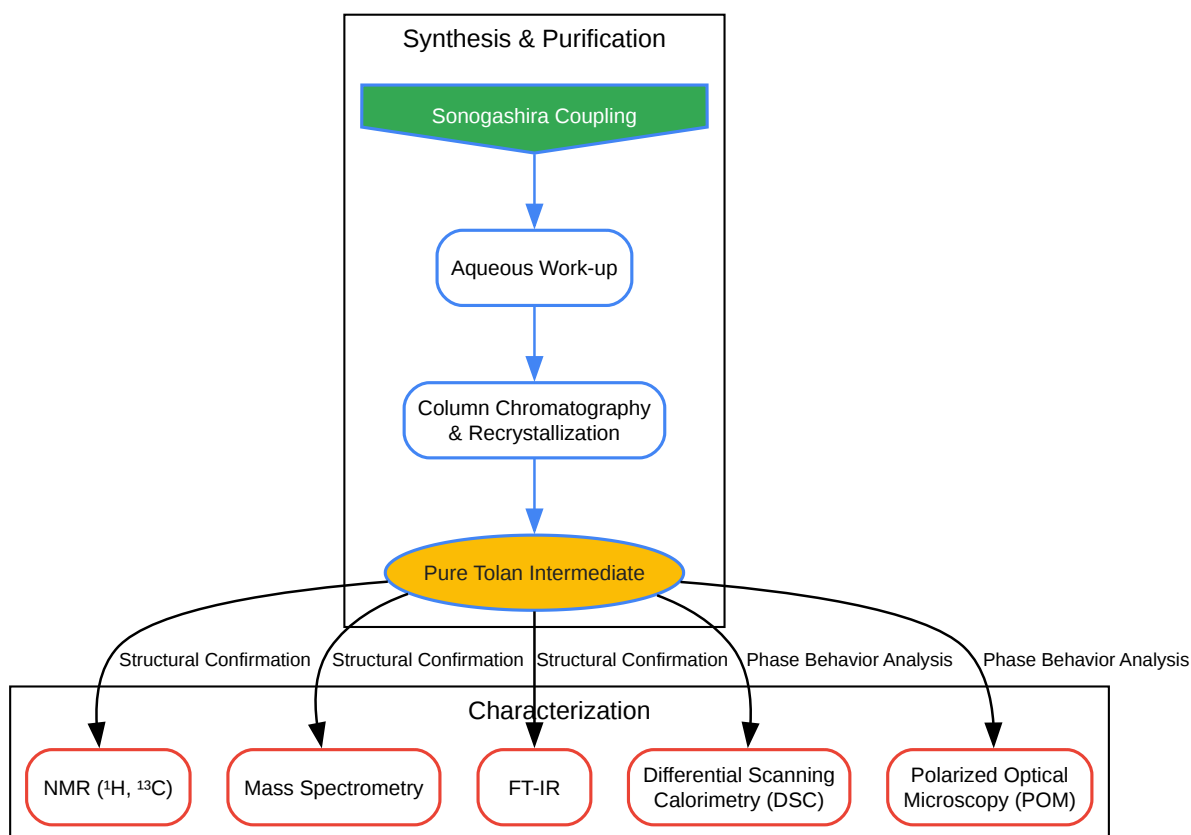

[Click to download full resolution via product page](#)

Caption: Workflow from synthesis to structural and thermal characterization.

Structural Confirmation

- NMR Spectroscopy (^1H & ^{13}C): Provides definitive structural information. For 4-methoxy-4'-pentyltolane, one would expect to see characteristic aromatic proton signals, singlets for the methoxy group protons, and aliphatic signals for the pentyl chain. The ^{13}C NMR would show the key quaternary alkyne carbons around 80-90 ppm.
- FT-IR Spectroscopy: Useful for confirming the presence of key functional groups. A sharp, medium-intensity peak around $2200\text{-}2230\text{ cm}^{-1}$ is characteristic of the $\text{C}\equiv\text{C}$ triple bond

stretch.

- Mass Spectrometry (HRMS): High-Resolution Mass Spectrometry is used to confirm the exact molecular weight of the compound, providing definitive evidence of its elemental composition.

Purity and Thermal Behavior Analysis

The purity and phase behavior of liquid crystal intermediates are inextricably linked.

- Differential Scanning Calorimetry (DSC): This is the primary technique for determining the thermal transitions of a material.^{[1][7][17]} A sample is heated and cooled at a controlled rate, and the heat flow is measured. Endothermic and exothermic peaks correspond to phase transitions, such as melting (Crystal → Nematic/Smectic/Isotropic) and clearing (Nematic/Smectic → Isotropic). The temperatures and enthalpy changes of these transitions are hallmarks of a specific liquid crystalline material.
- Polarized Optical Microscopy (POM): POM allows for the direct visualization and identification of liquid crystal mesophases.^{[1][18][19]} When a liquid crystalline sample is viewed between crossed polarizers, it appears birefringent (bright) and displays characteristic optical textures, while an isotropic liquid appears dark. Nematic phases often show "schlieren" or "marbled" textures. Observing these textures upon heating and cooling confirms the transition temperatures identified by DSC.

Conclusion

The synthesis of arylalkyne-based intermediates, particularly tolanes, via the Sonogashira cross-coupling reaction is a robust and highly efficient strategy for accessing the core structures of calamitic liquid crystals. A deep understanding of the reaction mechanism informs rational choices for reaction conditions, leading to high yields and purity. The protocols outlined herein, which combine a well-controlled synthesis with a comprehensive suite of characterization techniques, provide a reliable framework for researchers to produce high-quality liquid crystal intermediates, paving the way for the development of next-generation materials for displays, sensors, and other advanced optoelectronic applications.

References

- Sonogashira coupling - Wikipedia. Available at: [\[Link\]](#)
- Sonogashira Coupling - Chemistry LibreTexts. (2024). Available at: [\[Link\]](#)
- McKeown, N. B., & Painters, M. K. (1999). Palladium-catalysed cross-coupling reactions in the synthesis of some high polarizability materials. *Liquid Crystals*, 14(3). Available at: [\[Link\]](#)
- Hao, G., et al. (2006). Synthesis and mesomorphic properties of tolane-based liquid crystals with a fluorinated polar end group. *Liquid Crystals*, 33(10). Available at: [\[Link\]](#)
- Sonogashira Coupling: Mechanism, Steps & Applications Explained - Vedantu. Available at: [\[Link\]](#)
- Sonogashira Coupling - Organic Chemistry Portal. Available at: [\[Link\]](#)
- Sonogashira Coupling Reaction Mechanism - YouTube. (2016). Available at: [\[Link\]](#)
- Understanding Tolan: The Unsung Hero of Liquid Crystal Technology - Oreate AI Blog. (2024). Available at: [\[Link\]](#)
- Chen, R., et al. (2017). Synthesis and properties of allyloxy-based tolane liquid crystals with high negative dielectric anisotropy. *Liquid Crystals*. Available at: [\[Link\]](#)
- Dąbrowski, R., et al. (2003). New Tolan-type Liquid Crystals with 1, 3-Dithiane Ring. *Molecular Crystals and Liquid Crystals*. Available at: [\[Link\]](#)
- Amer, A. M., et al. (2011). Synthesis, Characterization and Texture Observations of Calamitic Liquid Crystalline Compounds. *International Journal of Molecular Sciences*, 12(11), 7317–7331. Available at: [\[Link\]](#)
- Abro, M. I., et al. (2016). CHARACTERIZATION OF LIQUID CRYSTALS: A LITERATURE REVIEW. *Bahria University Journal of Information & Communication Technologies*. Available at: [\[Link\]](#)
- Al-Dujaili, A. H., Jenkins, A. D., & Walton, D. R. M. (1984). Liquid-Crystal Polymers with Tolan Units. *Molecular Crystals and Liquid Crystals Incorporating Nonlinear Optics*, 112(1-2). Available at: [\[Link\]](#)

- characterization techniques for liquid crystal materials and its application in optoelectronics devices. (2020). International Journal of Creative Research Thoughts. Available at: [\[Link\]](#)
- Rout, T., et al. (2020). Preparation, Characterization and Applications of Liquid Crystals: A Review. IOSR Journal of Applied Chemistry. Available at: [\[Link\]](#)
- Synthesis and characterisation of novel calamitic liquid crystalline compounds. (2024). Molecular Crystals and Liquid Crystals. Available at: [\[Link\]](#)
- Soman, S. S., et al. (2022). design, synthesis and study of calamitic liquid crystals containing chalcone and schiff base. Journal of Advanced Scientific Research. Available at: [\[Link\]](#)
- Compositional Analysis of Merck E7 Liquid Crystal Intermediates Using UltraPerformance Convergence Chromatography (UPC2) with PDA Detection | Waters. Available at: [\[Link\]](#)
- Core-Only Calamitic Liquid Crystals: Molecular Design and Optoelectronic Properties - PMC. Available at: [\[Link\]](#)
- Synthesis, Characterization and Study the Liquid Crystalline Properties of New Discotic Compounds. Available at: [\[Link\]](#)
- Carbon-Carbon Cross Coupling Reactions in Ionic Liquids Catalysed by Palladium Metal Nanoparticles - MDPI. Available at: [\[Link\]](#)
- Colacot, T. J. (2022). Pd-Catalyzed Cross-Couplings: On the Importance of the Catalyst Quantity Descriptors, mol % and ppm. Organic Process Research & Development, 26(7), 1849–1863. Available at: [\[Link\]](#)
- 2.2: Pd-Catalyzed Cross Coupling Reactions - Chemistry LibreTexts. (2023). Available at: [\[Link\]](#)
- Svidrnoch, M., et al. (2022). Liquid crystals purity assay using nonaqueous capillary electrokinetic chromatography. ELECTROPHORESIS, 43(21-22), 2202–2209. Available at: [\[Link\]](#)
- Heck Reaction - Organic Chemistry Portal. Available at: [\[Link\]](#)

- Heck reaction - Wikipedia. Available at: [\[Link\]](#)
- 7.10. Sonogashira Coupling Between a Vinylic Halide and a Terminal Alkyne - Books. Available at: [\[Link\]](#)
- Sonogashira cross-coupling for the synthesis of materials-oriented... - ResearchGate. Available at: [\[Link\]](#)
- Purification of synthesis intermediates - Séché Environnement. Available at: [\[Link\]](#)

Need Custom Synthesis?

BenchChem offers custom synthesis for rare earth carbides and specific isotopic labeling.

Email: info@benchchem.com or [Request Quote Online](#).

Sources

1. Synthesis, Characterization and Texture Observations of Calamitic Liquid Crystalline Compounds - PMC [[pmc.ncbi.nlm.nih.gov](https://pubmed.ncbi.nlm.nih.gov)]
2. Core-Only Calamitic Liquid Crystals: Molecular Design and Optoelectronic Properties - PMC [[pmc.ncbi.nlm.nih.gov](https://pubmed.ncbi.nlm.nih.gov)]
3. nahrainuniv.edu.iq [nahrainuniv.edu.iq]
4. Understanding Tolan: The Unsung Hero of Liquid Crystal Technology - Oreate AI Blog [oreateai.com]
5. tandfonline.com [tandfonline.com]
6. tandfonline.com [tandfonline.com]
7. iosrjournals.org [iosrjournals.org]
8. Palladium-catalyzed Cross-coupling Reactions [sigmaaldrich.cn]
9. Sonogashira coupling - Wikipedia [en.wikipedia.org]
10. chem.libretexts.org [chem.libretexts.org]
11. Sonogashira Coupling [organic-chemistry.org]
12. Sonogashira Coupling: Mechanism, Steps & Applications Explained [vedantu.com]
13. youtube.com [youtube.com]

- [14. chem.libretexts.org \[chem.libretexts.org\]](https://chem.libretexts.org)
- [15. pdf.benchchem.com \[pdf.benchchem.com\]](https://pdf.benchchem.com)
- [16. Liquid crystals purity assay using nonaqueous capillary electrokinetic chromatography - PubMed \[pubmed.ncbi.nlm.nih.gov\]](https://pubmed.ncbi.nlm.nih.gov)
- [17. researchgate.net \[researchgate.net\]](https://researchgate.net)
- [18. ipme.ru \[ipme.ru\]](https://ipme.ru)
- [19. ijmr.net.in \[ijmr.net.in\]](https://ijmr.net.in)
- To cite this document: BenchChem. [Synthesis of liquid crystal intermediates from arylalkynes]. BenchChem, [2026]. [Online PDF]. Available at: [\[https://www.benchchem.com/product/b11826730/docs#synthesis-of-liquid-crystal-intermediates-from-arylalkynes\]](https://www.benchchem.com/product/b11826730/docs#synthesis-of-liquid-crystal-intermediates-from-arylalkynes)

Disclaimer & Data Validity:

The information provided in this document is for Research Use Only (RUO) and is strictly not intended for diagnostic or therapeutic procedures. While BenchChem strives to provide accurate protocols, we make no warranties, express or implied, regarding the fitness of this product for every specific experimental setup.

Technical Support: The protocols provided are for reference purposes. Unsure if this reagent suits your experiment?

Need Industrial/Bulk Grade? [Request Custom Synthesis Quote](#)

BenchChem

Our mission is to be the trusted global source of essential and advanced chemicals, empowering scientists and researchers to drive progress in science and industry.

Contact

Address: 3281 E Guasti Rd

Ontario, CA 91761, United States

Phone: (601) 213-4426

Email: info@benchchem.com

Contact our Ph.D. Support Team for a compatibility check