

# Evaluating TCO-PEG6-Acid Labeling Specificity in Complex Media: A Comparative Guide

**Author:** BenchChem Technical Support Team. **Date:** April 2026

## Compound of Interest

Compound Name: TCO-PEG6-acid

Cat. No.: B11826421

[Get Quote](#)

For researchers, scientists, and drug development professionals, the ability to specifically label and track biomolecules in complex biological environments is paramount. This guide provides an objective comparison of **TCO-PEG6-acid**, a popular reagent for bioorthogonal labeling, with alternative methods. We present supporting experimental data, detailed protocols, and visual workflows to assist in selecting the most appropriate labeling strategy for your research needs.

## Introduction to TCO-PEG6-Acid and Bioorthogonal Labeling

**TCO-PEG6-acid** is a heterobifunctional linker that enables the attachment of a trans-cyclooctene (TCO) moiety to a biomolecule of interest. The TCO group is highly reactive towards tetrazine-containing probes in a reaction known as the inverse-electron-demand Diels-Alder (IEDDA) cycloaddition. This "click chemistry" reaction is exceptionally fast and bioorthogonal, meaning it proceeds with high efficiency and specificity in biological systems without interfering with native biochemical processes.<sup>[1]</sup> The PEG6 spacer in **TCO-PEG6-acid** enhances water solubility and minimizes steric hindrance, while the terminal carboxylic acid allows for straightforward conjugation to primary amines on biomolecules like proteins.

The specificity of a labeling method is crucial, as non-specific interactions can lead to high background signals and confounding results. This guide focuses on evaluating the labeling specificity of **TCO-PEG6-acid** in complex media, such as cell lysates, and compares its performance against two other widely used bioorthogonal labeling techniques: Copper(I)-Catalyzed Azide-Alkyne Cycloaddition (CuAAC) and Strain-Promoted Azide-Alkyne Cycloaddition (SPAAC).

## Head-to-Head Comparison of Bioorthogonal Labeling Methods

The choice of a bioorthogonal labeling strategy depends on several factors, including reaction kinetics, efficiency, and potential for non-specific background labeling. The following table summarizes key performance metrics for TCO-tetrazine ligation (iEDDA), CuAAC, and SPAAC.

Feature	TCO-Tetrazine Ligation (iEDDA)	Copper(I)-Catalyzed Azide-Alkyne Cycloaddition (CuAAC)	Strain-Promoted Azide-Alkyne Cycloaddition (SPAAC)
Reaction Rate Constant ( $M^{-1}s^{-1}$ )	Up to $10^7$ [1]	$10 - 10^4$	$\sim 1$
Labeling Efficiency in Cell Lysate	100%	9%	45%
Biocompatibility	Excellent (catalyst-free)	Limited by copper cytotoxicity	Excellent (catalyst-free)
Background Labeling	Very low	Can have background from thiol-alkyne reactions[2][3]	Prone to background from reactions with cysteine-containing proteins[4]
Reaction Conditions	Aqueous media, room temperature	Requires copper(I) catalyst, ligands, and reducing agents	Aqueous media, room temperature

## Signaling Pathways and Experimental Workflows

To visually represent the chemical reactions and experimental procedures described, the following diagrams were generated using Graphviz (DOT language).

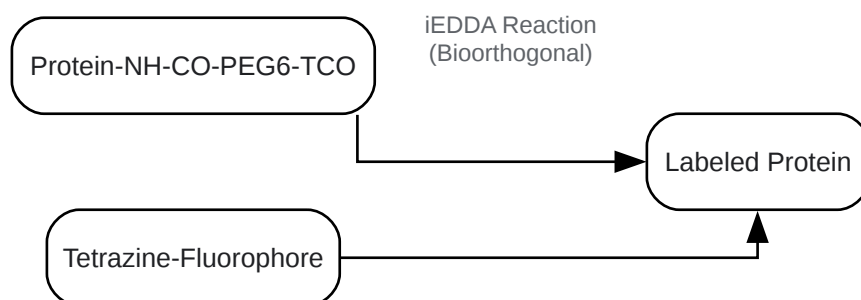

[Click to download full resolution via product page](#)

TCO-Tetrazine Ligation Pathway

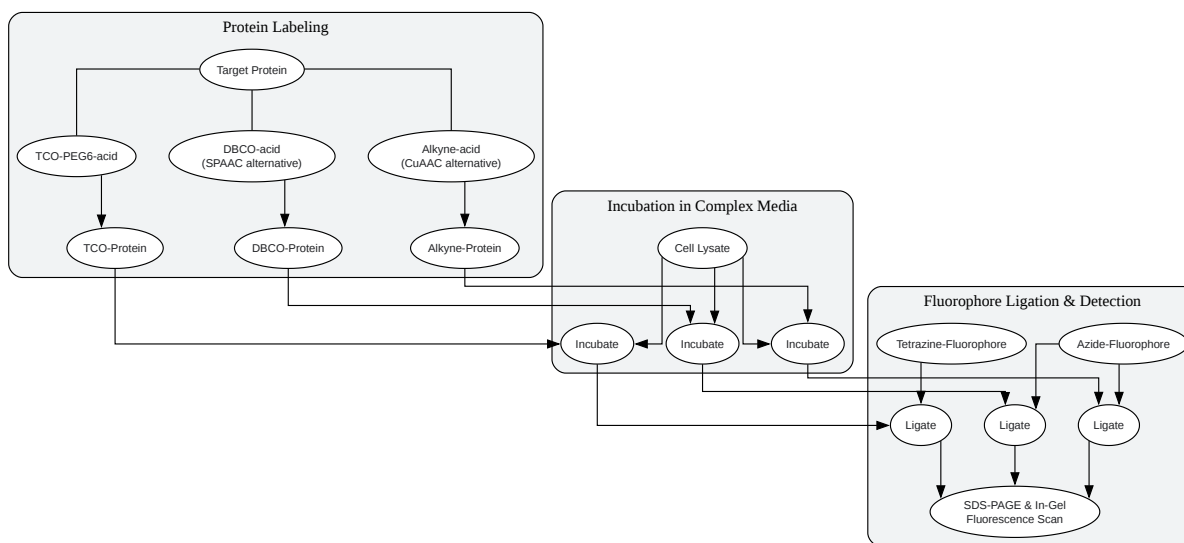

[Click to download full resolution via product page](#)

### Comparative Labeling Specificity Workflow

## Experimental Protocols

The following is a detailed protocol for a comparative analysis of labeling specificity in cell lysate.

Objective: To compare the specificity of protein labeling in cell lysate using **TCO-PEG6-acid** (for iEDDA), a DBCO-containing linker (for SPAAC), and an alkyne-containing linker (for CuAAC), followed by ligation to a fluorescent probe and analysis by in-gel fluorescence.

Materials:

- Protein of Interest (POI): Purified protein with available primary amines (e.g., lysine residues).
- Labeling Reagents:
  - **TCO-PEG6-acid**
  - DBCO-PEG4-acid (or similar SPAAC-compatible linker)
  - Alkyne-PEG4-acid (or similar CuAAC-compatible linker)
- Activation Reagents: EDC (1-ethyl-3-(3-dimethylaminopropyl)carbodiimide) and Sulfo-NHS (N-hydroxysulfosuccinimide).
- Fluorescent Probes:
  - Tetrazine-fluorophore (e.g., Tetrazine-TAMRA)
  - Azide-fluorophore (e.g., Azide-TAMRA)
- Cell Lysate: Prepared from a relevant cell line (e.g., HeLa, HEK293T) in a non-amine-containing lysis buffer (e.g., RIPA buffer without Tris).
- CuAAC Catalysts: Copper(II) sulfate ( $\text{CuSO}_4$ ), Tris(3-hydroxypropyltriazolylmethyl)amine (THPTA), and sodium ascorbate.
- Buffers and Reagents: Phosphate-buffered saline (PBS), pH 7.4; SDS-PAGE gels; protein loading buffer.
- Equipment: Gel electrophoresis system, fluorescence gel scanner.

Protocol:

## Part 1: Protein Labeling with Bioorthogonal Handles

- Reagent Preparation:
  - Dissolve the POI in PBS at a concentration of 1-5 mg/mL.
  - Prepare stock solutions of **TCO-PEG6-acid**, DBCO-PEG4-acid, and Alkyne-PEG4-acid in DMSO (e.g., 10 mM).
  - Prepare fresh stock solutions of EDC (e.g., 100 mM in water) and Sulfo-NHS (e.g., 100 mM in water).
- Amine Coupling Reaction:
  - In separate microcentrifuge tubes, combine the POI with a 20-fold molar excess of the respective linker (**TCO-PEG6-acid**, DBCO-PEG4-acid, or Alkyne-PEG4-acid).
  - Add EDC and Sulfo-NHS to a final concentration of 5 mM each.
  - Incubate the reactions for 1 hour at room temperature.
  - Remove excess, unreacted linker and coupling reagents by dialysis or using a desalting column equilibrated with PBS.
  - Determine the final concentration of the labeled proteins.

## Part 2: Labeling Specificity in Cell Lysate

- Reaction Setup:
  - For each labeled protein (TCO-POI, DBCO-POI, and Alkyne-POI), set up a reaction tube containing cell lysate (final protein concentration of 1-2 mg/mL).
  - Add the labeled protein to the cell lysate to a final concentration of 1-5  $\mu$ M.
  - As negative controls, set up reactions with unlabeled POI and cell lysate alone.
- Fluorescent Probe Ligation:

- For TCO-POI (iEDDA): Add the tetrazine-fluorophore to a final concentration of 25  $\mu\text{M}$ . Incubate for 30 minutes at room temperature.
- For DBCO-POI (SPAAC): Add the azide-fluorophore to a final concentration of 50  $\mu\text{M}$ . Incubate for 1 hour at room temperature.
- For Alkyne-POI (CuAAC):
  - Prepare a fresh catalyst premix: combine  $\text{CuSO}_4$  (final concentration 1 mM) and THPTA (final concentration 5 mM).
  - Add the azide-fluorophore (final concentration 50  $\mu\text{M}$ ) to the reaction tube.
  - Add the catalyst premix.
  - Initiate the reaction by adding freshly prepared sodium ascorbate to a final concentration of 5 mM.
  - Incubate for 1 hour at room temperature.

### Part 3: Analysis by In-Gel Fluorescence

- Sample Preparation:
  - To each reaction, add 4x protein loading buffer. Do not boil the samples to preserve the fluorescence.
  - Load equal amounts of total protein per lane onto an SDS-PAGE gel.
- Electrophoresis and Imaging:
  - Run the gel according to standard procedures.
  - After electrophoresis, rinse the gel with deionized water.
  - Scan the gel using a fluorescence imager with the appropriate excitation and emission wavelengths for the fluorophore used (e.g., TAMRA).[5]

- After fluorescence scanning, the gel can be stained with Coomassie Blue to visualize total protein loading.[5]

#### Expected Results:

- **TCO-PEG6-acid (iEDDA)**: A distinct fluorescent band corresponding to the molecular weight of the POI is expected, with minimal background fluorescence in the lane.
- **DBCO-linker (SPAAC)**: A fluorescent band for the POI should be visible, but there may be additional, fainter background bands due to non-specific reactions with cysteine-containing proteins in the lysate.[4]
- **Alkyne-linker (CuAAC)**: A band for the POI may be observed, but significant background labeling is possible due to side reactions with thiols.[2][3] The negative control lanes (unlabeled POI and lysate only) should show no significant fluorescence.

## Conclusion

The experimental evidence strongly suggests that the TCO-tetrazine ligation (iEDDA) offers superior specificity and efficiency for labeling biomolecules in complex media compared to CuAAC and SPAAC.[1] The exceptionally fast reaction kinetics and the bioorthogonality of the TCO-tetrazine pair result in high-yield labeling with minimal off-target reactions. While CuAAC and SPAAC are valuable tools in bioorthogonal chemistry, researchers should be aware of their potential for generating background signals, particularly in environments rich in thiols, such as cell lysates. For applications demanding high specificity and a clean signal, **TCO-PEG6-acid** and the iEDDA reaction represent the current gold standard.

#### *Need Custom Synthesis?*

*BenchChem offers custom synthesis for rare earth carbides and specific isotopic labeling.*

*Email: [info@benchchem.com](mailto:info@benchchem.com) or [Request Quote Online](#).*

## References

- 1. [benchchem.com](https://www.benchchem.com) [[benchchem.com](https://www.benchchem.com)]

- [2. Cu-Catalyzed Azide–Alkyne–Thiol Reaction Forms Ubiquitous Background in Chemical Proteomic Studies - PMC \[pmc.ncbi.nlm.nih.gov\]](#)
- [3. pubs.acs.org \[pubs.acs.org\]](#)
- [4. Comparative analysis of Cu \(I\)-catalyzed alkyne-azide cycloaddition \(CuAAC\) and strain-promoted alkyne-azide cycloaddition \(SPAAC\) in O-GlcNAc proteomics - PMC \[pmc.ncbi.nlm.nih.gov\]](#)
- [5. Preparation of Protein Lysates Using Biorthogonal Chemical Reporters for Click Reaction and in-Gel Fluorescence Analysis - PMC \[pmc.ncbi.nlm.nih.gov\]](#)
- To cite this document: BenchChem. [Evaluating TCO-PEG6-Acid Labeling Specificity in Complex Media: A Comparative Guide]. BenchChem, [2026]. [Online PDF]. Available at: [<https://www.benchchem.com/product/b11826421/docs#evaluating-tco-peg6-acid-labeling-specificity-in-complex-media-a-comparative-guide>]

---

#### Disclaimer & Data Validity:

The information provided in this document is for Research Use Only (RUO) and is strictly not intended for diagnostic or therapeutic procedures. While BenchChem strives to provide accurate protocols, we make no warranties, express or implied, regarding the fitness of this product for every specific experimental setup.

**Technical Support:** The protocols provided are for reference purposes. Unsure if this reagent suits your experiment?

**Need Industrial/Bulk Grade?** [Request Custom Synthesis Quote](#)

## BenchChem

Our mission is to be the trusted global source of essential and advanced chemicals, empowering scientists and researchers to drive progress in science and industry.

#### Contact

Address: 3281 E Guasti Rd

Ontario, CA 91761, United States

Phone: (601) 213-4426

Email: [info@benchchem.com](mailto:info@benchchem.com)

Contact our Ph.D. Support Team for a compatibility check