

# A Comparative Guide to the Mass Spectrometry Fragmentation Patterns of C<sub>10</sub>H<sub>9</sub>ClFNO<sub>3</sub>

**Author:** BenchChem Technical Support Team. **Date:** May 2026

## Compound of Interest

Compound Name: C<sub>10</sub>H<sub>9</sub>ClFNO<sub>3</sub>

Cat. No.: B11820691

[Get Quote](#)

**Abstract:** This guide provides an in-depth analysis of the theoretical mass spectrometry fragmentation patterns for the molecular formula **C<sub>10</sub>H<sub>9</sub>ClFNO<sub>3</sub>**. As no single, well-documented compound for this formula is readily available in common chemical literature, this guide will utilize a plausible, representative structure—1-(but-2-en-1-yloxy)-2-chloro-4-fluoro-5-nitrobenzene—to explore the fragmentation behavior under both hard and soft ionization techniques. This document is intended for researchers, scientists, and drug development professionals seeking to understand how complex molecules with multiple functional groups behave in a mass spectrometer, enabling better structural elucidation and analytical method development.

## Introduction: Deconstructing the Target Molecule

The structural elucidation of novel or unknown compounds is a cornerstone of chemical research. Mass spectrometry (MS) is an indispensable tool in this endeavor, providing critical information about a molecule's mass and, through its fragmentation patterns, its structure.<sup>[1]</sup> The subject of this guide is the fragmentation behavior of a molecule with the formula **C<sub>10</sub>H<sub>9</sub>ClFNO<sub>3</sub>** (Molecular Weight: ~261.64 g/mol).

To illustrate the principles of fragmentation for this formula, we have selected a representative isomer: 1-(but-2-en-1-yloxy)-2-chloro-4-fluoro-5-nitrobenzene.

Representative Structure:

- Molecular Formula: **C<sub>10</sub>H<sub>9</sub>ClFNO<sub>3</sub>**
- IUPAC Name: 1-(but-2-en-1-yloxy)-2-chloro-4-fluoro-5-nitrobenzene
- Key Structural Features:
  - Substituted Aromatic Ring: A stable core that often results in a prominent molecular ion.[2]
  - Nitro Group (-NO<sub>2</sub>): An electron-withdrawing group that influences fragmentation through characteristic losses of NO and NO<sub>2</sub>. [3]
  - Halogens (-Cl, -F): Chlorine's isotopic pattern (<sup>35</sup>Cl/<sup>37</sup>Cl) provides a distinctive signature, and halogen loss is a common pathway.[4]
  - Ether Linkage (-O-): A site for predictable alpha and C-O bond cleavages.[1]
  - Unsaturated Alkyl Chain: The butenyl group introduces possibilities for allylic cleavage and rearrangement reactions.

This guide will compare and contrast the fragmentation patterns generated by Electron Ionization (EI), a high-energy "hard" ionization technique, and Electrospray Ionization (ESI), a "soft" ionization method typically coupled with tandem mass spectrometry (MS/MS).

## Electron Ionization (EI-MS): Unraveling the Structure through Extensive Fragmentation

Electron Ionization (70 eV) is a classic technique that imparts significant energy into the analyte molecule, leading to the formation of an energetically unstable molecular ion (M<sup>+•</sup>) that undergoes extensive and often complex fragmentation.[5] The resulting spectrum is a rich fingerprint of the molecule's structure.

### The Molecular Ion (M<sup>+•</sup>)

The aromatic nature of the core structure suggests that the molecular ion peak should be observable. A key diagnostic feature will be the isotopic pattern of chlorine:

- M<sup>+</sup> Peak: m/z 261 (containing <sup>35</sup>Cl)
- M+2 Peak: m/z 263 (containing <sup>37</sup>Cl) The relative intensity of these peaks is expected to be approximately 3:1, which is a classic indicator of a single chlorine atom in the fragment.[4]

## Primary Fragmentation Pathways

The initial fragmentation of the M<sup>+</sup> is dictated by the weakest bonds and the formation of the most stable products (cations and neutral radicals).

- Ether Bond Cleavage ( $\alpha$ -cleavage): The C-O bond of the ether is a likely point of initial fragmentation. Cleavage can occur on either side of the oxygen atom.
  - Loss of the Butenyl Group: Cleavage of the O-C<sub>4</sub>H<sub>7</sub> bond can form a stable phenoxy cation. The positive charge typically resides on the more substituted or resonance-stabilized fragment.
  - Allylic Cleavage: The most favorable cleavage of the butenyl side chain is at the C-C bond beta to the double bond, which is also alpha to the ether oxygen. This would lead to the loss of a methyl radical ( $\bullet$ CH<sub>3</sub>) to form a resonance-stabilized oxonium ion.
- Nitro Group Fragmentations: Aromatic nitro compounds characteristically lose small nitrogen oxide species.[3]
  - Loss of  $\bullet$ NO<sub>2</sub>: A common fragmentation pathway, leading to a fragment at m/z 215.
  - Loss of  $\bullet$ NO: Often followed by the loss of CO, this pathway can also occur, leading to a fragment at m/z 231.
- Halogen Loss: Direct cleavage of the C-Cl bond can occur, though loss of the entire side chain or nitro group is often more favorable.

## Proposed EI Fragmentation Scheme

The interplay of these pathways leads to a complex but interpretable spectrum. The most probable major fragmentation pathways are visualized below.

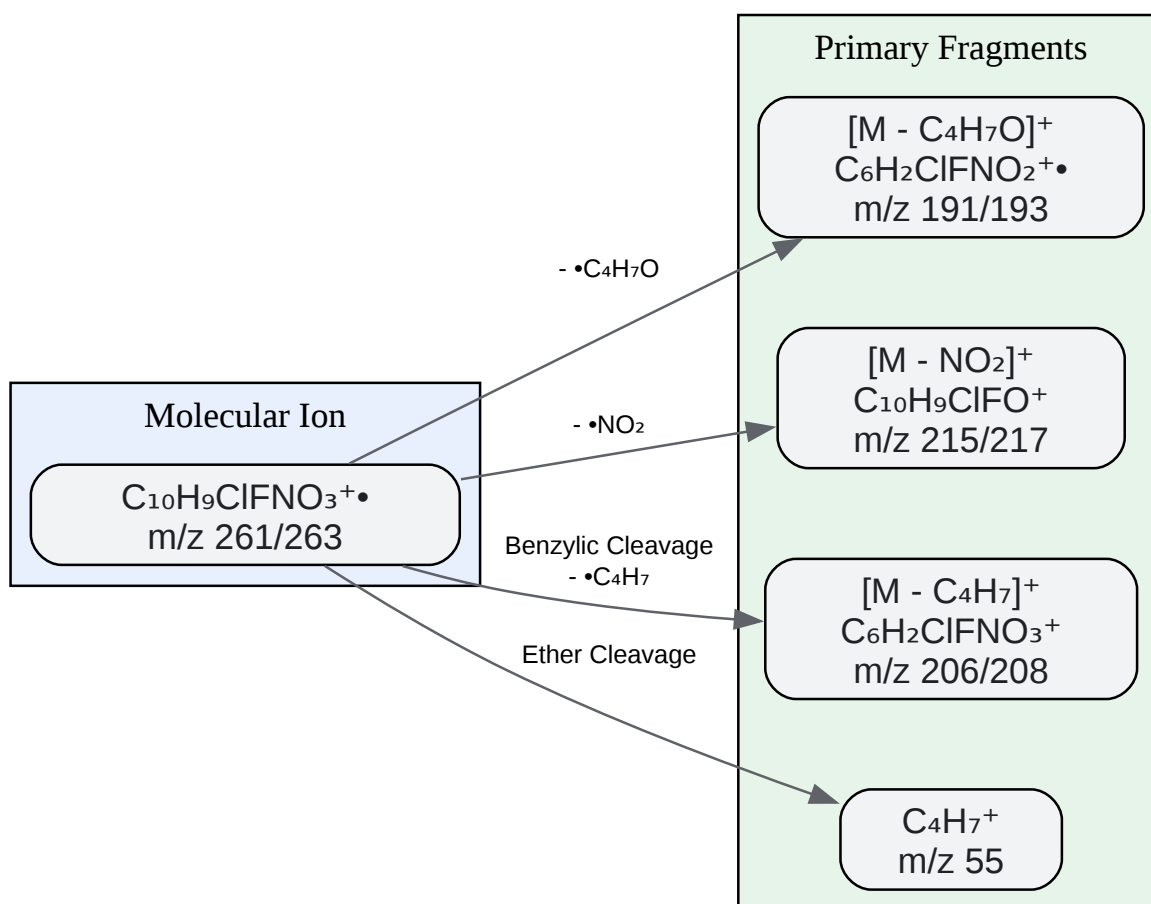

[Click to download full resolution via product page](#)

Caption: Proposed major EI fragmentation pathways for the molecular ion of 1-(but-2-en-1-yloxy)-2-chloro-4-fluoro-5-nitrobenzene.

## Summary of Predicted EI Fragments

m/z ( <sup>35</sup> Cl)	Proposed Formula	Neutral Loss	Structural Origin / Comments
261	C <sub>10</sub> H <sub>9</sub> ClFNO <sub>3</sub> <sup>+</sup> •	-	Molecular Ion (M <sup>+</sup> •)
215	C <sub>10</sub> H <sub>9</sub> ClFO <sup>+</sup>	•NO <sub>2</sub>	Loss of the nitro group.
206	C <sub>6</sub> H <sub>2</sub> ClFNO <sub>3</sub> <sup>+</sup>	•C <sub>4</sub> H <sub>7</sub>	Cleavage of the ether C-O bond, charge on the aromatic moiety.
191	C <sub>6</sub> H <sub>2</sub> ClFNO <sub>2</sub> <sup>+</sup> •	•C <sub>4</sub> H <sub>7</sub> O	Loss of the entire ether side chain as a radical.
175	C <sub>6</sub> H <sub>2</sub> ClFO <sup>+</sup>	•C <sub>4</sub> H <sub>7</sub> , •NO	Loss of side chain and nitric oxide.
55	C <sub>4</sub> H <sub>7</sub> <sup>+</sup>	C <sub>6</sub> H <sub>2</sub> ClFNO <sub>3</sub> •	Butenyl cation, from ether cleavage with charge on the alkyl chain.

## Electrospray Ionization (ESI-MS/MS): Targeted Fragmentation of Precursor Ions

ESI is a soft ionization technique that typically generates protonated [M+H]<sup>+</sup> or deprotonated [M-H]<sup>-</sup> molecules with minimal in-source fragmentation.[6] Structural information is then obtained by selecting this precursor ion and subjecting it to collision-induced dissociation (CID) in a tandem mass spectrometer (MS/MS).

Given the presence of the electron-withdrawing nitro group on the aromatic ring, this molecule is likely to ionize most efficiently in negative ion mode, forming a deprotonated molecule [M-H]<sup>-</sup>.

## Precursor Ion Formation

- Precursor Ion:  $[M-H]^-$  at  $m/z$  260/262. The loss of a proton is most likely from the butenyl chain, forming a stabilized carbanion.

## Proposed ESI-MS/MS Fragmentation Pathways

The fragmentation of even-electron ions like  $[M-H]^-$  in CID is dominated by the loss of stable, neutral molecules rather than radicals.[5]

- Loss of  $NO_2$ : The nitroaromatic moiety is prone to fragmentation. A likely pathway is the loss of a neutral  $NO_2$  molecule (46 Da). This is often a characteristic fragmentation for nitroaromatic compounds in negative-ion ESI.[5]
- Ether Bond Cleavage: The C-O bond can cleave, potentially leading to the formation of the stable chlorofluoronitrophenoxide anion.
- Rearrangements: Complex rearrangements involving the side chain could lead to losses of  $C_4H_6$  (butene).

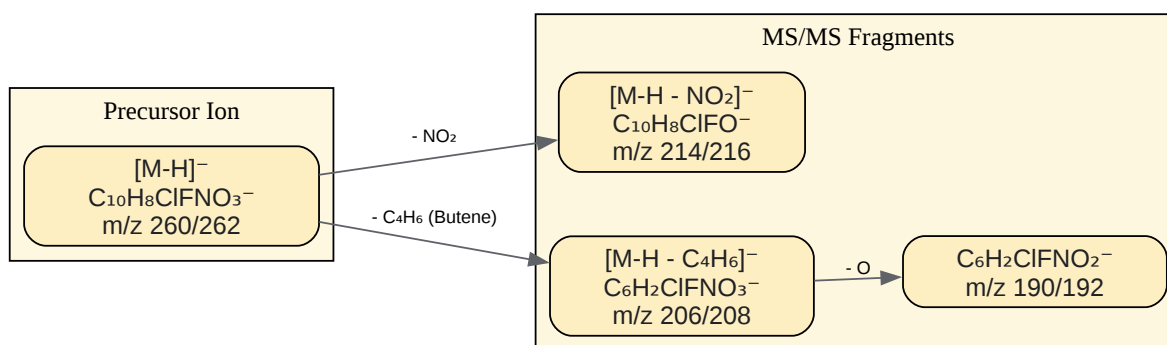

[Click to download full resolution via product page](#)

Caption: Proposed ESI-MS/MS fragmentation of the deprotonated molecule  $[M-H]^-$ .

## Summary of Predicted ESI-MS/MS Fragments

Precursor m/z ( <sup>35</sup> Cl)	Fragment m/z ( <sup>35</sup> Cl)	Proposed Formula	Neutral Loss	Comments
260	214	C <sub>10</sub> H <sub>8</sub> ClFO <sup>-</sup>	NO <sub>2</sub>	Loss of neutral nitrogen dioxide.
260	206	C <sub>6</sub> H <sub>2</sub> ClFNO <sub>3</sub> <sup>-</sup>	C <sub>4</sub> H <sub>6</sub>	Loss of butene via rearrangement and cleavage.
260	190	C <sub>6</sub> H <sub>2</sub> ClFNO <sub>2</sub> <sup>-</sup>	C <sub>4</sub> H <sub>6</sub> , O	Formation of the chlorofluoronitrophenoxide anion.

## Comparative Analysis: EI-MS vs. ESI-MS/MS

The choice of ionization technique fundamentally alters the information obtained and should be guided by the analytical goal.

Feature	Electron Ionization (EI-MS)	Electrospray Ionization (ESI-MS/MS)	Rationale / Insight
Ionization Type	Hard Ionization	Soft Ionization	EI provides extensive fragmentation useful for library matching and fingerprinting. ESI preserves the molecular species for targeted fragmentation.
Molecular Ion	$M^{+\bullet}$ (m/z 261), often observable but can be weak.	$[M-H]^-$ (m/z 260), typically the strong base peak in the MS1 scan.	ESI is superior for confirming the molecular weight of the analyte.
Fragmentation	Extensive, non-selective, radical-driven.	Controlled, selective, loss of neutral molecules.	EI fragmentation reveals the entire molecular skeleton. ESI-MS/MS allows for targeted structural analysis by selecting specific fragmentation channels.
Primary Information	Structural fingerprint, identification of stable substructures.	Molecular weight confirmation, targeted structural analysis of specific bonds.	The two techniques are complementary: ESI confirms what it is (by mass), while EI helps determine how it is put together (by fragments).

## Experimental Protocols

To obtain the data discussed, rigorous and well-defined experimental protocols are necessary.

## Protocol for GC-EI-MS Analysis

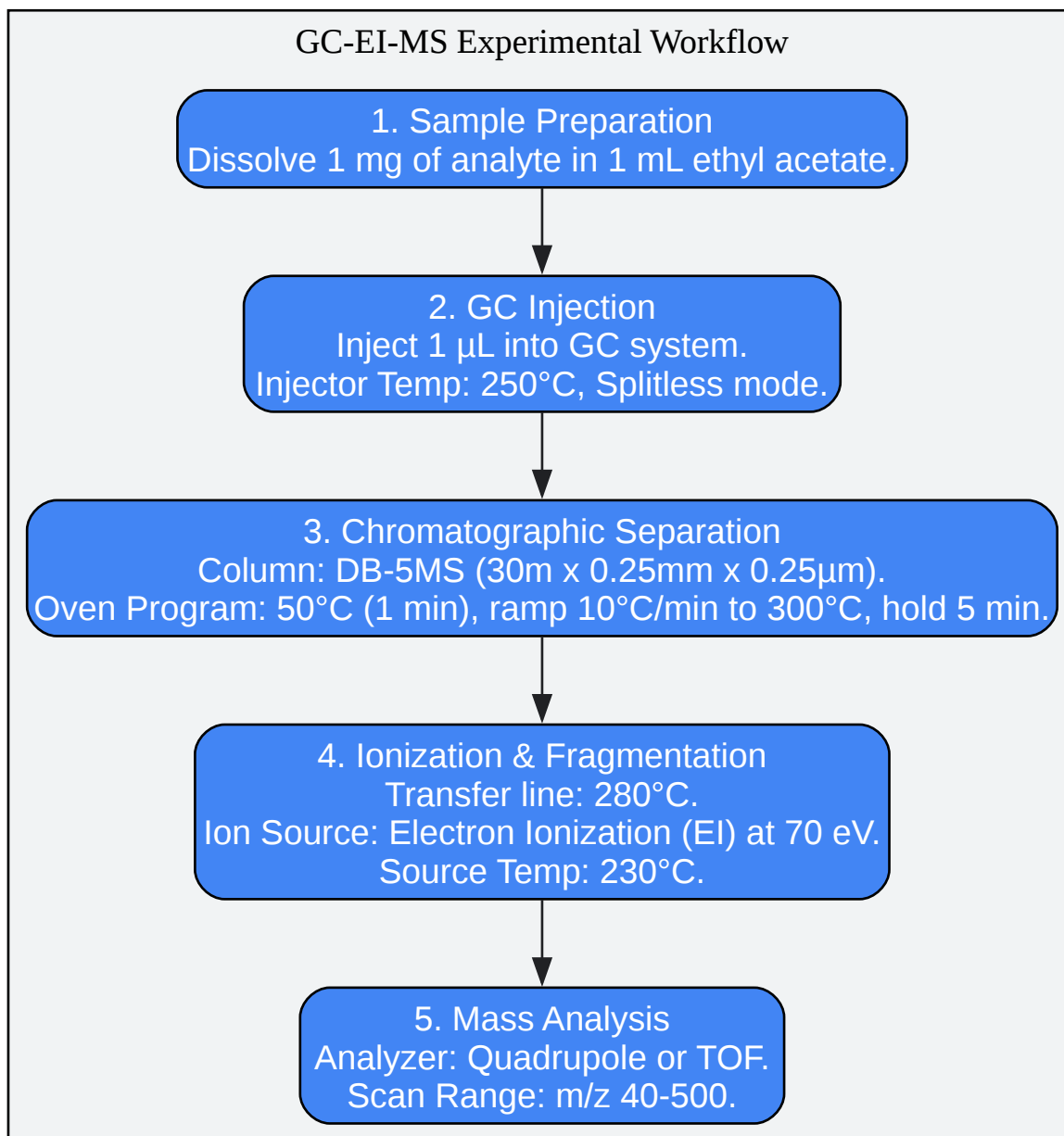

[Click to download full resolution via product page](#)

Caption: Standard workflow for analyzing a semi-volatile organic compound using GC-EI-MS.

## Protocol for LC-ESI-MS/MS Analysis

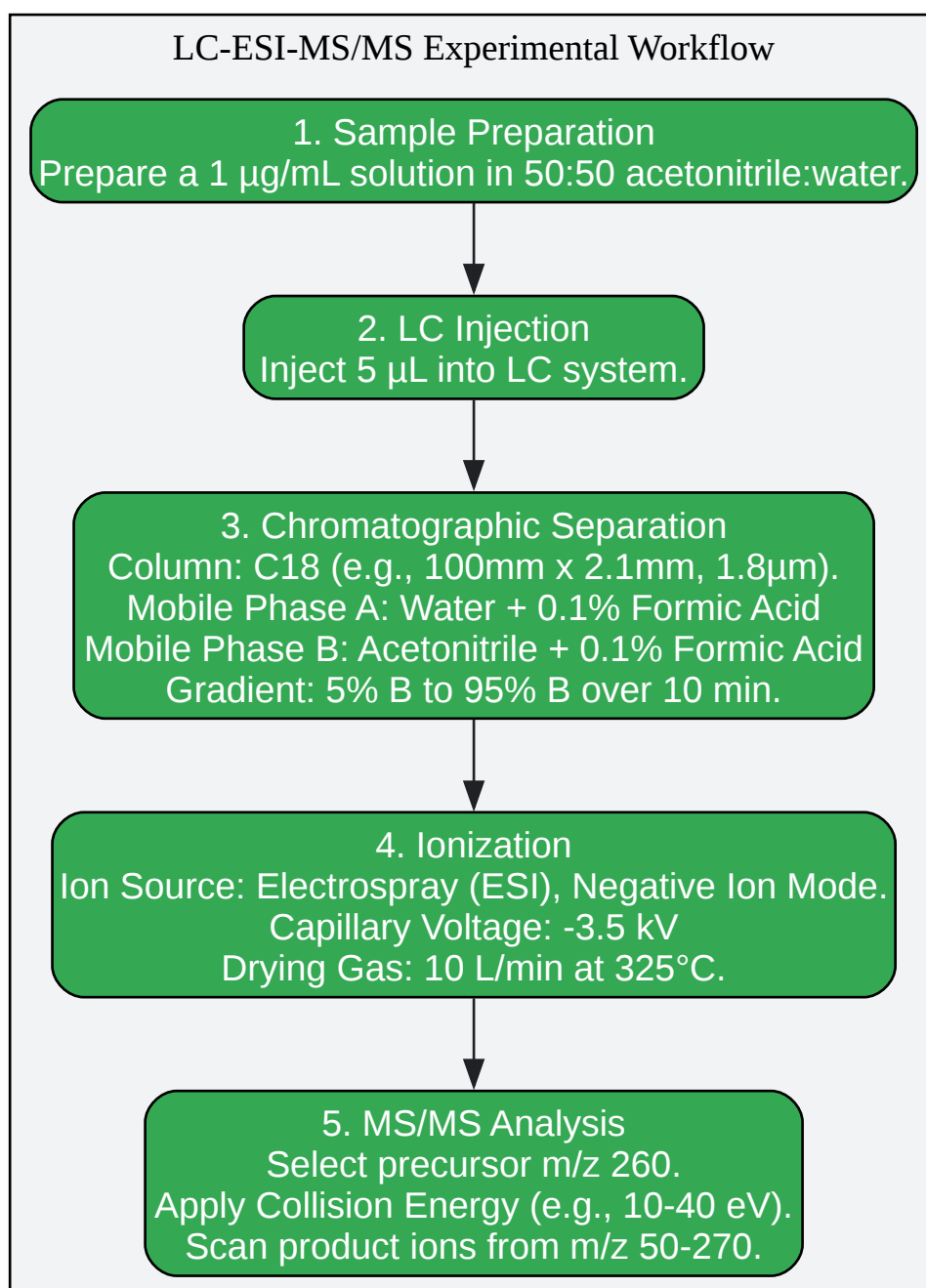

[Click to download full resolution via product page](#)

Caption: Standard workflow for analyzing a polar organic compound using LC-ESI-MS/MS.

## Conclusion

The mass spectrometric fragmentation of a molecule like 1-(but-2-en-1-yloxy)-2-chloro-4-fluoro-5-nitrobenzene is a complex process governed by the interplay of its diverse functional groups.

Electron Ionization provides a detailed structural fingerprint through extensive, high-energy fragmentation, highlighting pathways such as nitro group loss and ether bond cleavage. In contrast, Electrospray Ionization coupled with tandem MS allows for the confirmation of molecular weight and targeted structural interrogation through the controlled dissociation of a deprotonated precursor ion. By comparing the data from both techniques, researchers can build a comprehensive and confident picture of the molecule's identity and structure, demonstrating the synergistic power of modern mass spectrometry.

## References

- Mass Spectrometry of Nitro and Nitroso Compounds. ResearchGate. [\[Link\]](#)
- Fragmentation in Mass Spectrometry - Ethers. YouTube. [\[Link\]](#)
- Fragmentation reactions using electrospray ionization mass spectrometry. RSC Publishing. [\[Link\]](#)
- Investigation of the ionisation and fragmentation behaviour of different nitroaromatic compounds...using electrospray ionisation tandem mass spectrometry. PubMed. [\[Link\]](#)
- Fragmentation (mass spectrometry). Wikipedia. [\[Link\]](#)
- Mass spectra and fragmentation mechanisms. Canadian Science Publishing. [\[Link\]](#)
- Studies on Nitroaromatic Compound Degradation...by Electrospray Ionization Tandem Mass Spectrometry. ResearchGate. [\[Link\]](#)
- Mass Spectrum Interpretation. Purdue University. [\[Link\]](#)
- Fragmentation of Nitroaromatic Compounds in ESI-MS/MS. ResearchGate. [\[Link\]](#)
- Fragmentation Patterns in Mass Spectra. Chemistry LibreTexts. [\[Link\]](#)
- Mass Spectrometry of Common Functional Groups. Chemistry LibreTexts. [\[Link\]](#)
- Fragmentation reactions using ESI-MS. ResearchGate. [\[Link\]](#)
- Fragmentation Patterns of Alkyl Halides. Chad's Prep. [\[Link\]](#)

- Fragmentation of Aromatic Compounds. YouTube. [[Link](#)]
- Fragmentation of Aromatics. Chapter 2: Fragmentation and Interpretation of Spectra. [[Link](#)]

### Need Custom Synthesis?

BenchChem offers custom synthesis for rare earth carbides and specific isotopic labeling.

Email: [info@benchchem.com](mailto:info@benchchem.com) or [Request Quote Online](#).

## Sources

- [1. youtube.com](https://www.youtube.com) [[youtube.com](https://www.youtube.com)]
- [2. m.youtube.com](https://m.youtube.com) [[m.youtube.com](https://m.youtube.com)]
- [3. m.youtube.com](https://m.youtube.com) [[m.youtube.com](https://m.youtube.com)]
- [4. chem.libretexts.org](https://chem.libretexts.org) [[chem.libretexts.org](https://chem.libretexts.org)]
- [5. researchgate.net](https://www.researchgate.net) [[researchgate.net](https://www.researchgate.net)]
- [6. Investigation of the ionisation and fragmentation behaviour of different nitroaromatic compounds occurring as polar metabolites of explosives using electrospray ionisation tandem mass spectrometry - PubMed](#) [[pubmed.ncbi.nlm.nih.gov](https://pubmed.ncbi.nlm.nih.gov)]
- To cite this document: BenchChem. [A Comparative Guide to the Mass Spectrometry Fragmentation Patterns of C<sub>10</sub>H<sub>9</sub>ClFNO<sub>3</sub>]. BenchChem, [2026]. [Online PDF]. Available at: [<https://www.benchchem.com/product/b11820691/docs#a-comparative-guide-to-the-mass-spectrometry-fragmentation-patterns-of-c10h9clfno3>]

---

### Disclaimer & Data Validity:

The information provided in this document is for Research Use Only (RUO) and is strictly not intended for diagnostic or therapeutic procedures. While BenchChem strives to provide accurate protocols, we make no warranties, express or implied, regarding the fitness of this product for every specific experimental setup.

**Technical Support:** The protocols provided are for reference purposes. Unsure if this reagent suits your experiment?

**Need Industrial/Bulk Grade?** [Request Custom Synthesis Quote](#)

## BenchChem

Our mission is to be the trusted global source of essential and advanced chemicals, empowering scientists and researchers to drive progress in science and industry.

### Contact

Address: 3281 E Guasti Rd  
Ontario, CA 91761, United States  
Phone: (601) 213-4426  
Email: [info@benchchem.com](mailto:info@benchchem.com)

[Contact our Ph.D. Support Team for a compatibility check](#)