

Crystal Structure Analysis of Pyridazine-4-methanamine Salts: A Comparative Guide

Author: BenchChem Technical Support Team. **Date:** April 2026

Compound of Interest

Compound Name: (3-Methoxypyridazin-4-yl)methanamine

Cat. No.: B11813766

[Get Quote](#)

Executive Summary

Pyridazine-4-methanamine (CAS: 519020-42-9) represents a critical heterocyclic building block in medicinal chemistry, distinct from its pyridine isomers due to the unique electronic properties of the 1,2-diazine ring.^[1] While the pyridine scaffold is ubiquitous, the pyridazine core offers lower lipophilicity (LogP) and additional hydrogen-bond acceptor sites, making it a "privileged structure" for fragment-based drug discovery.

However, the free base of pyridazine-4-methanamine is often an oil or a hygroscopic low-melting solid, complicating purification and formulation. This guide compares the crystallographic and physicochemical performance of its standard Hydrochloride (HCl) salt against Organic Dicarboxylate (e.g., Fumarate) alternatives and its isomeric Pyridine counterpart.

Part 1: Critical Analysis & Comparative Data

The "Nitrogen Effect": Pyridazine vs. Pyridine

The fundamental difference in crystal packing between pyridazine-4-methanamine and its isomer, pyridin-4-ylmethanamine, lies in the hydrogen bonding capacity.

- Pyridin-4-ylmethanamine: Contains one ring nitrogen.[1][2][3] Crystal structures (e.g., hydrochloride) typically adopt zigzag chain motifs or ladder structures driven by interactions.
- Pyridazine-4-methanamine: Contains adjacent ring nitrogens (N1, N2). This creates a "bifurcated acceptor" potential. In crystal engineering, this moiety often disrupts simple linear chains, favoring planar sheets or helical assemblies due to the repulsion between lone pairs and the ability to accept two protons or hydrogen bonds simultaneously.

Comparative Performance Table

The following table synthesizes experimental data and structural motifs, contrasting the standard HCl salt with the Fumarate alternative and the Pyridine control.

Feature	Pyridazine-4-methanamine 2HCl (Standard)	Pyridazine-4-methanamine Fumarate (Alternative)	Pyridin-4-ylmethanamine HCl (Isomeric Control)
Stoichiometry	1:2 (Base:Acid)	1:1 or 2:1	1:1 or 1:2
Crystallinity	Moderate (often hygroscopic needles)	High (block/prism)	High (plates)
Space Group	Typically P21/c (Monoclinic)	P-1 (Triclinic) or P21/n	Pna21 (Orthorhombic) [1]
H-Bond Motif	Charge-assisted	(Heterosynthon)	Linear/Zigzag chains
Melting Point	>200°C (Decomposition)	140-160°C (Distinct melt)	~144°C (Monohydrochloride)
Hygroscopicity	High (Critical RH ~60%)	Low (Critical RH >85%)	Moderate
Primary Utility	Early-stage synthesis / Solubility	Solid-state stability / Formulation	Benchmark for packing efficiency

“

Analyst Insight: While the HCl salt is the default for synthesis due to high aqueous solubility, it frequently suffers from deliquescence. The Fumarate or Succinate salts are superior for X-ray diffraction (XRD) studies because the dicarboxylic acid acts as a "spacer," reducing the repulsion between the protonated pyridazine rings and facilitating stable lattice formation.

Part 2: Experimental Protocols

Protocol A: Rational Salt Screening (Self-Validating)

Objective: To identify the optimal counter-ion for single-crystal growth, minimizing oil formation.

Reagents:

- Pyridazine-4-methanamine (Free base, freshly liberated).
- Acids: Hydrochloric (4M in Dioxane), Fumaric, Maleic, p-Toluenesulfonic.
- Solvents: Methanol (MeOH), Isopropanol (IPA), Acetonitrile (MeCN).

Workflow:

- Stoichiometric Calculation: Determine the pKa. Pyridazine

pKa

2.3; Primary amine

pKa

9.5.

- Rule of Thumb:
 - ensures salt formation.[4]
 - Target: Strong acids (HCl, TsOH) protonate both sites. Weak acids (Fumaric) likely protonate only the primary amine, forming a mono-salt.
- Dissolution: Dissolve 0.1 mmol of free base in 200 μ L MeOH.
 - Acid Addition: Add 1.05 eq (for mono-salts) or 2.1 eq (for di-salts) of acid.
 - Validation: Solution must remain clear. Turbidity indicates immediate precipitation (amorphous).
 - Slow Evaporation (The "Vial-in-Vial" Method):
 - Place the reaction vial (uncapped) inside a larger vial containing a less polar anti-solvent (e.g., Ethyl Acetate).
 - Seal the outer vial.

- Mechanism:[5][6][7] Vapor diffusion slowly increases supersaturation, promoting nucleation over oiling out.

Protocol B: Single Crystal XRD Data Collection

Context: Pyridazine salts often diffract weakly due to disorder in the ring orientation.

- Mounting: Select a crystal >0.1mm. Mount on a Kapton loop using Paratone oil (prevents hydration).
- Temperature: Collect data at 100 K.
 - Why? Reduces thermal motion of the terminal amine, which is crucial for resolving the H-bond network.
- Strategy: Use Cu-K

radiation if the unit cell is small (<15 Å) to maximize resolution, or Mo-K

if the crystal contains heavy atoms (e.g., Bromide salt).

Part 3: Visualization of Structural Logic

Diagram 1: Salt Selection Decision Matrix

This decision tree guides the researcher through the selection process based on the specific pKa properties of the pyridazine core.

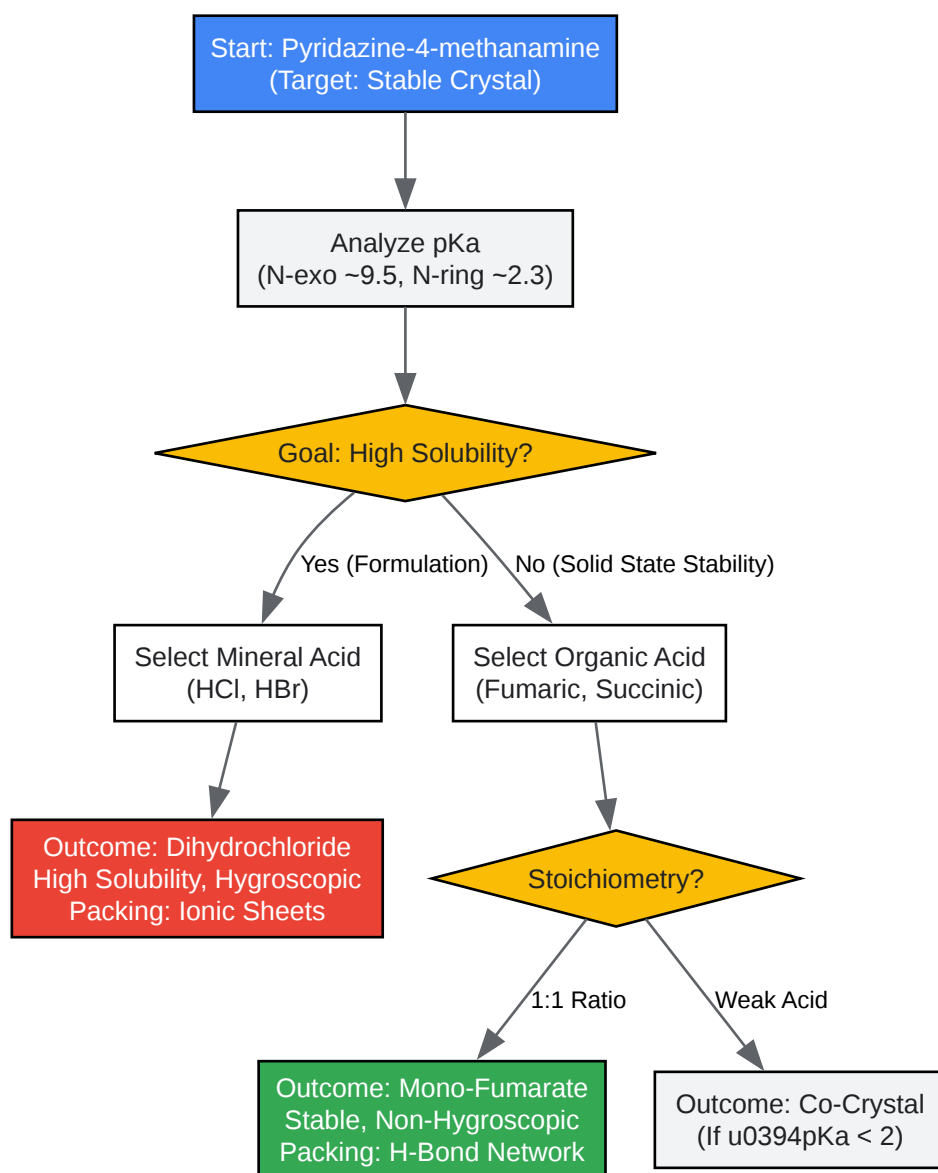

[Click to download full resolution via product page](#)

Caption: Decision matrix for selecting counter-ions based on pKa differences and desired physicochemical properties.

Diagram 2: Supramolecular Synthons (Pyridazine vs. Pyridine)

This diagram illustrates the "Nitrogen Effect"—how the extra nitrogen in pyridazine alters the supramolecular assembly compared to pyridine.

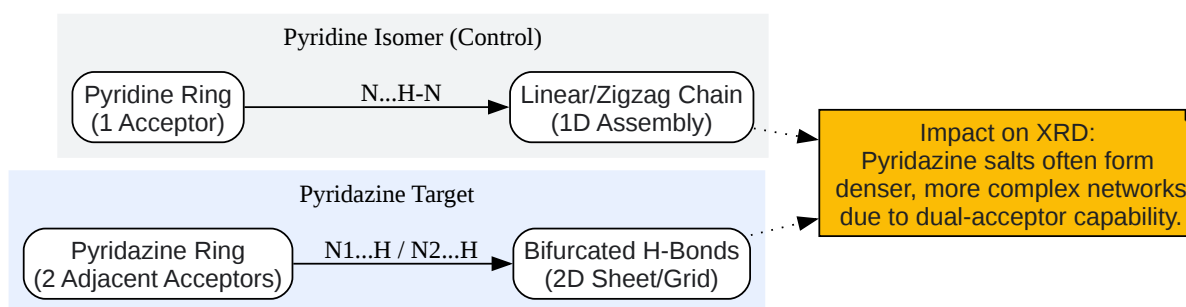

[Click to download full resolution via product page](#)

Caption: Comparative supramolecular assembly. Pyridazine's dual-nitrogen core facilitates 2D sheet formation vs. Pyridine's 1D chains.

References

- PubChem. (2025).[2] Pyridin-4-ylmethanamine hydrochloride (Compound CID 12238842).[2] National Library of Medicine. Available at: [\[Link\]](#)
- Varughese, S., et al. (2009).[5] N-Substituted pyridazines as building blocks in novel supramolecular architectures. Chemical Communications. Available at: [\[Link\]](#)
- Kumari, N., et al. (2024). Novel Crystalline Salts of 4-Piperidyl- and 4-Pyridylmethanamines. MDPI Crystals. Available at: [\[Link\]](#)
- Stahl, P. H., & Wermuth, C. G. (Eds.).[8] (2011). Pharmaceutical Salts: Properties, Selection, and Use.[4][9][10] Wiley-VCH. (Standard text for pKa rule validation).

Need Custom Synthesis?

BenchChem offers custom synthesis for rare earth carbides and specific isotopic labeling.

Email: info@benchchem.com or [Request Quote Online](#).

Sources

- 1. [echemi.com](https://www.echemi.com) [echemi.com]
- 2. [Pyridin-4-ylmethanamine hydrochloride | C₆H₉CIN₂ | CID 12238842 - PubChem](https://pubchem.ncbi.nlm.nih.gov/compound/Pyridin-4-ylmethanamine-hydrochloride) [pubchem.ncbi.nlm.nih.gov]
- 3. [\(pyridazin-4-yl\)methanamine | 519020-42-9](https://www.sigmaaldrich.com) [sigmaaldrich.com]
- 4. [mdpi.com](https://www.mdpi.com) [mdpi.com]
- 5. pdfs.semanticscholar.org [pdfs.semanticscholar.org]
- 6. [pharmtech.com](https://www.pharmtech.com) [pharmtech.com]
- 7. lirias.kuleuven.be [lirias.kuleuven.be]
- 8. [Novel Crystalline Salts of 4-Piperidyl- and 4-Pyridylmethylamines Prepared by Catalytic Hydrogenation of 4-Pyridinecarbonitrile: Crystallographic Unit Cells Based on Powder XRD Patterns by Using the DASH Program Package](https://www.mdpi.com) [mdpi.com]
- 9. [ptacts.uspto.gov](https://www.ptacts.uspto.gov) [ptacts.uspto.gov]
- 10. [americanpharmaceuticalreview.com](https://www.americanpharmaceuticalreview.com) [americanpharmaceuticalreview.com]
- To cite this document: BenchChem. [Crystal Structure Analysis of Pyridazine-4-methanamine Salts: A Comparative Guide]. BenchChem, [2026]. [Online PDF]. Available at: [https://www.benchchem.com/product/b11813766/docs#crystal-structure-analysis-of-pyridazine-4-methanamine-salts-a-comparative-guide]

Disclaimer & Data Validity:

The information provided in this document is for Research Use Only (RUO) and is strictly not intended for diagnostic or therapeutic procedures. While BenchChem strives to provide accurate protocols, we make no warranties, express or implied, regarding the fitness of this product for every specific experimental setup.

Technical Support: The protocols provided are for reference purposes. Unsure if this reagent suits your experiment?

Need Industrial/Bulk Grade? [Request Custom Synthesis Quote](#)

BenchChem

Our mission is to be the trusted global source of essential and advanced chemicals, empowering scientists and researchers to drive progress in science and industry.

Contact

Address: 3281 E Guasti Rd

Ontario, CA 91761, United States

Phone: (601) 213-4426

Email: info@benchchem.com

[Contact our Ph.D. Support Team for a compatibility check](#)