

# Definitive Structure Confirmation: A Comparative Guide to Integrated NMR & MS Workflows

**Author:** BenchChem Technical Support Team. **Date:** May 2026

## Compound of Interest

**Compound Name:** *N-Phenyl-3-(piperidin-2-yl)isoxazole-4-carboxamide*

**Cat. No.:** B11809099

[Get Quote](#)

## Executive Summary

In small molecule drug development, structural ambiguity is a critical failure point. While X-ray crystallography remains the ultimate arbiter of absolute configuration, it is often precluded by the physical state of the sample (e.g., oils, amorphous solids). Consequently, the industry standard for New Chemical Entity (NCE) confirmation has shifted to a hybridized evidence model: the integration of High-Resolution Mass Spectrometry (HR-MS) and Multi-Dimensional Nuclear Magnetic Resonance (NMR).

This guide objectively compares this integrated workflow against standalone alternatives, providing a validated protocol that aligns with ICH Q2(R2) and ICH Q14 regulatory expectations for analytical procedure development and validation.

## Part 1: Comparative Analysis of Structural Elucidation Methods

The following table contrasts the three primary methodologies employed in modern laboratories. The "Product" under review is the Integrated HR-MS + High-Field NMR workflow, compared against rapid screening (Method B) and absolute definition (Method C).

**Table 1: Performance Matrix of Elucidation Workflows**

| Feature            | Method A: Integrated Workflow (HR-MS + 600 MHz NMR) | Method B: Rapid Screen (LC-MS + Benchtop NMR) | Method C: X-Ray Crystallography (XRD) |
|--------------------|---|---|---------------------------------------|
| Primary Utility    | Full Structure Elucidation (De Novo)                | Verification of Known Structures              | Absolute Stereochemistry              |
| Sample Requirement | 1–5 mg (Soluble)                                    | >10 mg (NMR limit)                            | Single Crystal (Solid)                |
| Resolution         | Atomic connectivity + Formula                       | Functional Groups + Mass                      | 3D Spatial Coordinates                |
| Isomer Distinction | High (Regio- & Stereoisomers)                       | Low (Mass cannot distinguish isomers)         | Definitive                            |
| Throughput         | Moderate (Hours/Sample)                             | High (Minutes/Sample)                         | Low (Days/Weeks)                      |
| Regulatory Weight  | Gold Standard for solution-state APIs               | Insufficient for NCE registration             | Gold Standard for solid-state         |
| Cost Efficiency    | High (High CapEx, Low OpEx)                         | Moderate                                      | Low (High labor intensity)            |

## Why the Integrated Workflow (Method A) Wins

While Method B is faster, it fails the "Self-Validation" test for unknown impurities. A benchtop NMR (60-80 MHz) lacks the dispersion to resolve complex multiplets, and Low-Res MS cannot distinguish between

and

mass differences (approx. 0.011 Da). Method A is the only solution-state approach that satisfies the Unsaturation Number (DoU) cross-check, where the mass spectral formula dictates the required number of rings/double bonds, which must mathematically match the NMR signal distribution.

## Part 2: The Integrated Protocol (Step-by-Step)

This protocol is designed to be self-validating. If the data from Step 2 does not mathematically align with Step 3, the workflow halts. This causality loop prevents the propagation of structural errors.

### Phase 1: The Mass Spectral Foundation (Formula Confirmation)

Objective: Establish the molecular formula and Degrees of Unsaturation (DoU).

- Sample Prep: Dissolve ~0.1 mg in MeOH/ACN (50:50).
- Instrumentation: Use Q-TOF or Orbitrap (Resolution > 50,000 FWHM).
- Ionization:
  - ESI (+/-): For polar/ionizable compounds.
  - APCI: For non-polar, neutral compounds.
- Critical Output: Accurate Mass (ppm error).
- Calculation (The Causality Check):
  - Calculate Formula (e.g., ).
  - Calculate DoU:  
.
  - Stop Condition: If the isotopic pattern (M+1, M+2) does not match the predicted formula, do not proceed to NMR.

### Phase 2: The NMR Connectivity Map (Topology)

Objective: Map the atoms to the formula derived in Phase 1.

- Sample Prep: Dissolve 2–5 mg in 600  $\mu$ L deuterated solvent (e.g., DMSO-  
or  
).
  - Why? To provide a deuterium lock signal for field stability and render the solvent "invisible" in  
NMR.
- Experiment 1: Quantitative  
(1D):
  - Set relaxation delay (  
 ) to  
(typically 5–10s) for accurate integration.
  - Validation Step: Sum of integrals must equal the Hydrogen count from Phase 1.
- Experiment 2: HSQC (Heteronuclear Single Quantum Coherence):
  - Correlates protons directly to the carbons they are attached to (1-bond coupling).
  - Differentiation: Distinguishes  
,  
, and  
(via phase editing).
- Experiment 3: HMBC (Heteronuclear Multiple Bond Correlation):
  - Correlates protons to carbons 2-3 bonds away.
  - The "Bridge": This connects spin systems across heteroatoms (O, N) where protons are not directly attached.

## Part 3: Visualization of Logic & Workflows

### Diagram 1: The Self-Validating Decision Matrix

This diagram illustrates the logical flow. Note the "Red" feedback loops—these are the quality control gates that ensure scientific integrity.

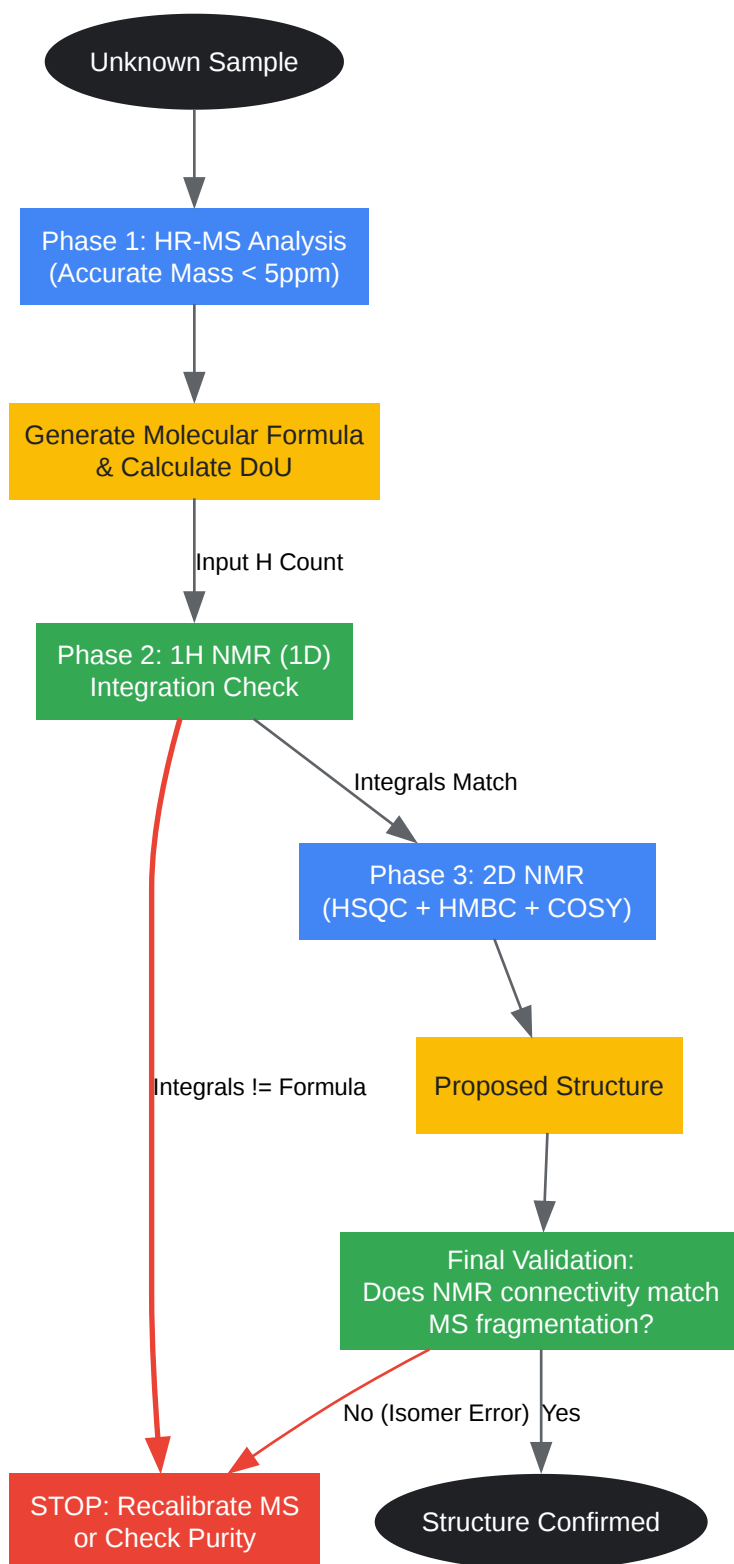

[Click to download full resolution via product page](#)

Caption: The logical decision tree for structure confirmation. Red pathways indicate mandatory "Stop/Re-evaluate" gates based on data mismatch.

## Diagram 2: The Connectivity Puzzle (HMBC vs. HSQC)

Understanding how to "build" the molecule using 2D data is crucial. This diagram visualizes the specific role of each experiment.

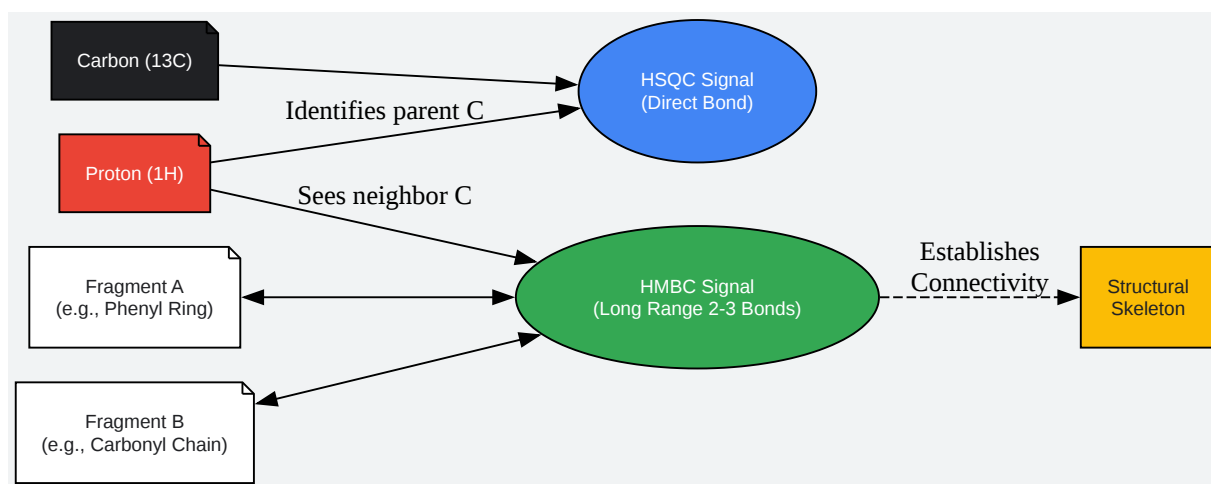

[Click to download full resolution via product page](#)

Caption: HSQC maps protons to their parent carbons, while HMBC bridges separate structural fragments (e.g., across ether linkages).

## Part 4: Supporting Data & Specifications

To ensure reproducibility, the following parameters are recommended based on current high-field instrument capabilities.

### Table 2: Sensitivity & Detection Limits

| Technique        | Detection Limit (LOD) | Quantitation Limit (LOQ) | Critical Parameter               |
|------------------|-----------------------|--------------------------|----------------------------------|
| HR-MS (Orbitrap) | ~10–100 femtograms    | ~1 picogram              | Ionization Efficiency            |
| NMR (600 MHz)    | ~10 micrograms        | ~0.1 mg                  | Cryoprobe vs. Room Temp Probe    |
| NMR (1D)         | ~1 mg                 | ~5 mg                    | Natural Abundance (1.1%)         |
| HSQC (2D)        | ~0.1 mg               | N/A (Qualitative)        | Indirect Detection (sensitivity) |

## Solvent Effects Data

Note: Solvent choice drastically affects chemical shift dispersion.

- DMSO-  
: Excellent for polar compounds; exchangeable protons ( , ) are often visible as sharp peaks (crucial for structural proof).
- : Standard, but exchangeable protons often broaden or disappear due to exchange with trace water.
- : All exchangeable protons disappear (become ), simplifying the spectrum but losing structural data regarding groups.

## References

- International Council for Harmonisation (ICH). (2023).[1][2] ICH Harmonised Guideline Q2(R2): Validation of Analytical Procedures. [[Link](#)]

- International Council for Harmonisation (ICH). (2023).[1][3] ICH Harmonised Guideline Q14: Analytical Procedure Development. [[Link](#)]
- U.S. Food and Drug Administration (FDA). (2015). Analytical Procedures and Methods Validation for Drugs and Biologics. [[Link](#)]
- Elyashberg, M., & Williams, A. (2015). Computer-Assisted Structure Elucidation: Logic and Methods. Annual Reports on NMR Spectroscopy. [[Link](#)]
- Holzgrabe, U. (2010). NMR spectroscopy in pharmaceutical analysis.[4][5][6][7] Elsevier. [[Link](#)]

### Need Custom Synthesis?

BenchChem offers custom synthesis for rare earth carbides and specific isotopic labeling.

Email: [info@benchchem.com](mailto:info@benchchem.com) or [Request Quote Online](#).

## Sources

- [1. intuitionlabs.ai \[intuitionlabs.ai\]](https://intuitionlabs.ai)
- [2. ICH Q2\(R2\) Validation of analytical procedures - Scientific guideline | European Medicines Agency \(EMA\) \[ema.europa.eu\]](https://www.ema.europa.eu/en/ich/q2r2-validation-of-analytical-procedures-scientific-guideline)
- [3. fda.gov \[fda.gov\]](https://www.fda.gov)
- [4. Comparison of LC-NMR and conventional NMR for structure elucidation in drug metabolism studies - PubMed \[pubmed.ncbi.nlm.nih.gov\]](https://pubmed.ncbi.nlm.nih.gov/28111111/)
- [5. scispace.com \[scispace.com\]](https://www.scispace.com)
- [6. resolvemass.ca \[resolvemass.ca\]](https://www.resolvemass.ca)
- [7. m.youtube.com \[m.youtube.com\]](https://www.youtube.com/watch?v=11809099)
- To cite this document: BenchChem. [Definitive Structure Confirmation: A Comparative Guide to Integrated NMR & MS Workflows]. BenchChem, [2026]. [Online PDF]. Available at: [<https://www.benchchem.com/product/b11809099/docs#definitive-structure-confirmation-a-comparative-guide-to-integrated-nmr-ms-workflows>]

---

### Disclaimer & Data Validity:

The information provided in this document is for Research Use Only (RUO) and is strictly not intended for diagnostic or therapeutic procedures. While BenchChem strives to provide accurate protocols, we make no warranties, express or implied, regarding the fitness of this product for every specific experimental setup.

**Technical Support:** The protocols provided are for reference purposes. Unsure if this reagent suits your experiment?

**Need Industrial/Bulk Grade?** [Request Custom Synthesis Quote](#)

## BenchChem

Our mission is to be the trusted global source of essential and advanced chemicals, empowering scientists and researchers to drive progress in science and industry.

### Contact

Address: 3281 E Guasti Rd  
Ontario, CA 91761, United States  
Phone: (601) 213-4426  
Email: [info@benchchem.com](mailto:info@benchchem.com)

[Contact our Ph.D. Support Team for a compatibility check](#)