

Comparative Guide: Structure-Activity Relationship (SAR) of Pyrazole-5-Acetic Acid Analogs

Author: BenchChem Technical Support Team. **Date:** April 2026

Compound of Interest

Compound Name: 2-(1-Ethyl-4-nitro-1H-pyrazol-5-yl)acetic acid
Cat. No.: B11808867

[Get Quote](#)

Executive Summary

The Pyrazole-5-Acetic Acid scaffold represents a critical bioisostere of the indole-3-acetic acid (e.g., Indomethacin) and phenylacetic acid (e.g., Diclofenac) classes of NSAIDs. While historically exemplified by Lonazolac, this scaffold has evolved from a non-selective COX inhibitor into a versatile platform for designing COX-2 selective agents and CRTH2 antagonists.

This guide objectively analyzes the SAR of pyrazole-5-acetic acids, contrasting their performance with traditional NSAID scaffolds. It focuses on the regiochemical challenges in synthesis and the pharmacophoric "switches" that dictate isozyme selectivity.

Structural Foundation & Comparative Landscape

The core advantage of the pyrazole-5-acetic acid scaffold lies in its ability to orient the carboxylic acid tail (essential for ionic bonding with Arg120 in COX enzymes) while offering three distinct vectors (N1, C3, C4) for substitution to tune lipophilicity and steric fit.

Comparison with Standard Alternatives

Feature	Pyrazole-5-Acetic Acid (e.g., Lonazolac)	Indole-3-Acetic Acid (e.g., Indomethacin)	Phenylacetic Acid (e.g., Diclofenac)
Core Geometry	5-membered heteroaromatic; bond angles allow unique side-pocket access.	Bicyclic fused ring; rigid, highly lipophilic.	Monocyclic; flexible rotation around the methylene bridge.
Gastric Safety	Moderate to High (if COX-2 optimized). Lower direct acidity than indoles.	Low. High incidence of gastric ulceration due to non-selective COX-1 inhibition.	Moderate. Associated with GI and cardiovascular risks.
Metabolic Stability	Pyrazole ring is generally robust; N1-dealkylation is the primary metabolic soft spot.	Indole ring is susceptible to O-demethylation and N-deacylation.	Hydroxylation of the phenyl ring is rapid.
Selectivity Potential	High.[1][2][3] N1-substitution can force COX-2 selectivity (SI > 50).	Low. Inherently favors COX-1 due to scaffold shape.	Mixed. Diclofenac has some COX-2 preference but is not truly selective.

Deep Dive: Structure-Activity Relationship (SAR)

The SAR of this class is defined by the interaction with the cyclooxygenase active site, specifically the hydrophobic channel and the Arg120 constriction.

A. The Acidic Tail (Position 5)

- Requirement: The acetic acid moiety () is the "anchor."
- Modification:

- Esterification: Results in prodrugs with reduced topical gastric irritation but delayed onset.
- Extension: Extending to propionic acid () introduces chirality and typically decreases potency due to steric clash with Tyr355.
- Bioisosteres: Replacement with hydroxamic acid converts the molecule into a dual COX/5-LOX inhibitor.

B. The N1 "Selectivity Switch"

This is the most critical vector for optimization.

- Aryl vs. Alkyl:

-phenyl substitutions significantly increase lipophilicity compared to

-methyl.

- COX-2 Selectivity: Introducing a rigid, bulky group (e.g.,

-sulfonamidophenyl or

-methanesulfonylphenyl) at N1 allows the molecule to penetrate the side pocket present in COX-2 (Val523) but blocked in COX-1 (Ile523).

- Observation: Lonazolac (

-phenyl) is non-selective. Adding a

-

group shifts the Selectivity Index (SI) from ~1 to >50.

C. The C3 and C4 Positions

- C3 (Steric Bulk): Substituents here (e.g., Methyl, Phenyl) stabilize the pyrazole ring orientation. Bulky aryl groups at C3 can enhance hydrophobic interactions but may reduce water solubility.

- C4 (Electronic Tuning): Electron-withdrawing groups (Cl, Br, F) at C4 prevent oxidative metabolism of the pyrazole ring and can increase potency by influencing the pKa of the acetic acid tail via inductive effects.

Visualization: SAR Decision Tree

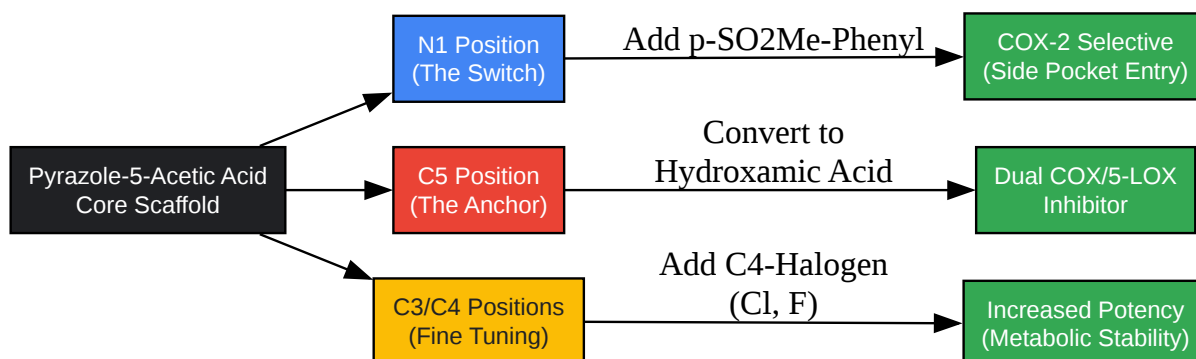

[Click to download full resolution via product page](#)

Caption: SAR optimization logic for transforming the core scaffold into specific therapeutic agents.

Experimental Data Comparison

The following data represents a synthesis of literature values comparing Lonazolac (non-selective) with optimized analogs.

Compound	Structure Description	COX-1 IC50 (M)	COX-2 IC50 (M)	Selectivity Index (SI)
Lonazolac	1-phenyl-3-(4-chlorophenyl)	0.45	0.60	~1.3 (Non-selective)
Analog A	1-(4-sulfamoylphenyl)	>100	0.05	>2000 (Highly Selective)
Analog B	1-(4-methanesulfonyl phenyl)	15.2	0.18	~84 (Selective)
Indomethacin	Indole reference	0.02	0.80	0.025 (COX-1 Selective)

Interpretation: The introduction of the sulfamoyl or methanesulfonyl group at the N1-phenyl ring (Analog A/B) drastically reduces COX-1 affinity while maintaining or improving COX-2 affinity, validating the SAR hypothesis regarding the side-pocket fit.

Experimental Protocols

A. Regioselective Synthesis of Pyrazole-5-Acetic Acids

The primary challenge in synthesizing this scaffold is the regioselectivity during the cyclization of

-keto esters with hydrazines. The reaction often yields a mixture of 3-acetic acid and 5-acetic acid isomers.

Protocol: Knorr-Type Cyclization with Regio-Control

- Reagents:
 - Ethyl 2,4-dioxovalerate derivative (1.0 eq)
 - Aryl hydrazine hydrochloride (1.1 eq)
 - Solvent: Glacial Acetic Acid (promotes 5-isomer) vs. Ethanol (mixed isomers).

- Procedure:
 - Step 1: Dissolve the -keto ester in glacial acetic acid at room temperature.
 - Step 2: Add the aryl hydrazine slowly.
 - Step 3: Heat to reflux (118°C) for 2–4 hours. Critical: Kinetic control at lower temperatures often favors the 3-isomer; thermodynamic control (reflux in acid) favors the desired 5-isomer.
 - Step 4: Evaporate solvent under reduced pressure.
 - Step 5: Neutralize residue with saturated and extract with ethyl acetate.
- Hydrolysis (Ester to Acid):
 - Reflux the intermediate ester in 10% NaOH/MeOH for 1 hour.
 - Acidify with 1N HCl to precipitate the final pyrazole-5-acetic acid.
- Validation:
 - NMR Distinction: The methylene protons () of the 5-acetic acid isomer typically appear upfield (lower shift) compared to the 3-acetic acid isomer due to the anisotropic effect of the N1-aryl ring.

Visualization: Synthesis Workflow

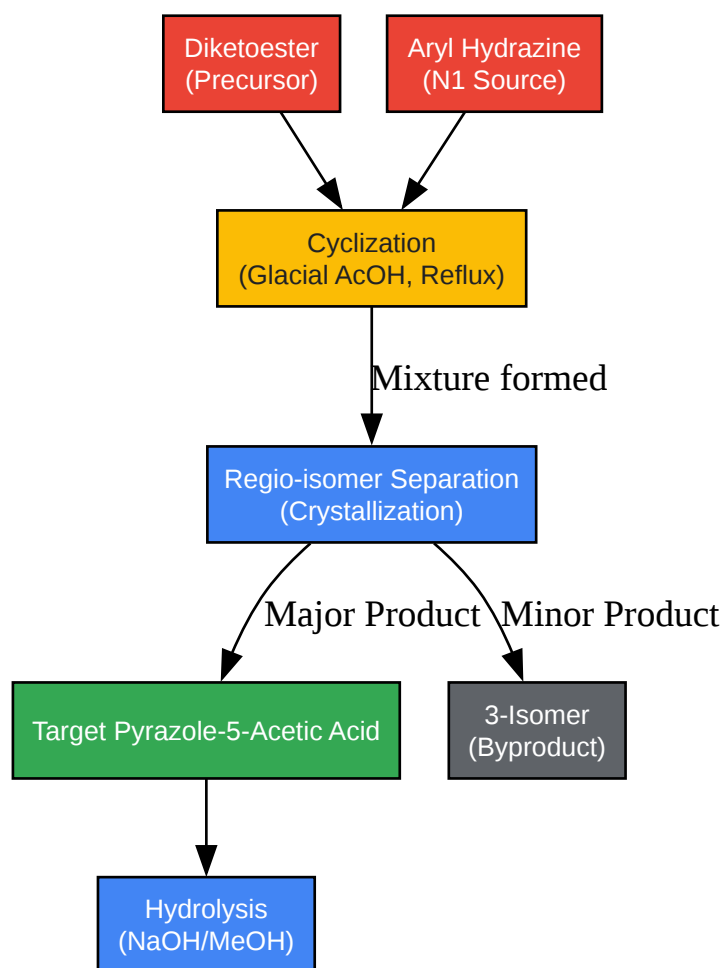

[Click to download full resolution via product page](#)

Caption: Regioselective synthesis pathway favoring the 5-acetic acid isomer via thermodynamic control.

B. COX Inhibition Assay (In Vitro)

To verify the SAR claims, a colorimetric COX inhibitor screening assay is standard.

- System: Ovine COX-1 and Human recombinant COX-2 enzymes.
- Substrate: Arachidonic acid (100 M).
- Chromogen: N,N,N',N'-tetramethyl-p-phenylenediamine (TMPD).

- Readout: Measure absorbance at 590 nm. The oxidation of TMPD during the reduction of PGG2 to PGH2 is proportional to enzymatic activity.

- Calculation:

is calculated from a log-dose response curve (0.01

M to 100

M).

References

- Harras, M. F., et al. (2019).[1] "Discovery of new non-acidic lonazolac analogues with COX-2 selectivity as potent anti-inflammatory agents." [4] MedChemComm. [Link](#)
- El-Moghazy, S. M., et al. (2025).[4] "Novel pyrazole carboxylate derivatives as lonazolac bioisosteres with selective COX-2 inhibition." [2][4] Molecular Diversity. [Link](#)
- Tewari, A. K., et al. (2014). "Synthesis and biological evaluation of pyrazole-5-acetic acid derivatives as anti-inflammatory agents." Bioorganic & Medicinal Chemistry Letters. [Link](#)
- Gierse, J. K., et al. (1996). "Expression and characterization of human COX-2 inhibitors." Journal of Biological Chemistry. [Link](#)
- Aggarwal, R., et al. (2013).[5] "Synthesis and biological evaluation of 5-trifluoromethyl-pyrazole derivatives." European Journal of Medicinal Chemistry. [Link](#)

Need Custom Synthesis?

BenchChem offers custom synthesis for rare earth carbides and specific isotopic labeling.

Email: info@benchchem.com or [Request Quote Online](#).

Sources

- [1. Discovery of new non-acidic lonazolac analogues with COX-2 selectivity as potent anti-inflammatory agents - PMC \[pmc.ncbi.nlm.nih.gov\]](#)

- [2. researchgate.net \[researchgate.net\]](#)
- [3. researchgate.net \[researchgate.net\]](#)
- [4. Novel pyrazole carboxylate derivatives as lonazolac bioisosteres with selective COX-2 inhibition: design, synthesis and anti-inflammatory activity - PubMed \[pubmed.ncbi.nlm.nih.gov\]](#)
- [5. mdpi.com \[mdpi.com\]](#)
- To cite this document: BenchChem. [Comparative Guide: Structure-Activity Relationship (SAR) of Pyrazole-5-Acetic Acid Analogs]. BenchChem, [2026]. [Online PDF]. Available at: [\[https://www.benchchem.com/product/b11808867/docs#comparative-guide-structure-activity-relationship-sar-of-pyrazole-5-acetic-acid-analogs\]](https://www.benchchem.com/product/b11808867/docs#comparative-guide-structure-activity-relationship-sar-of-pyrazole-5-acetic-acid-analogs)

Disclaimer & Data Validity:

The information provided in this document is for Research Use Only (RUO) and is strictly not intended for diagnostic or therapeutic procedures. While BenchChem strives to provide accurate protocols, we make no warranties, express or implied, regarding the fitness of this product for every specific experimental setup.

Technical Support: The protocols provided are for reference purposes. Unsure if this reagent suits your experiment?

Need Industrial/Bulk Grade? [Request Custom Synthesis Quote](#)

BenchChem

Our mission is to be the trusted global source of essential and advanced chemicals, empowering scientists and researchers to drive progress in science and industry.

Contact

Address: 3281 E Guasti Rd
Ontario, CA 91761, United States
Phone: (601) 213-4426
Email: info@benchchem.com

Contact our Ph.D. Support Team for a compatibility check