

# Nuclear Magnetic Resonance (NMR) Spectroscopy: The Cornerstone of Structural Analysis

**Author:** BenchChem Technical Support Team. **Date:** May 2026

## Compound of Interest

Compound Name: 2-(2,6-Dimethoxyphenyl)-1-  
methylpiperidine

Cat. No.: B11805639

[Get Quote](#)

NMR spectroscopy is the most powerful and informative technique for determining the solution-state structure of organic molecules. It provides detailed information about the chemical environment, connectivity, and spatial relationships of atoms within the molecule.

## Proton ( $^1\text{H}$ ) and Carbon ( $^{13}\text{C}$ ) NMR: Mapping the Carbon Skeleton

The initial step involves acquiring one-dimensional  $^1\text{H}$  and  $^{13}\text{C}$  NMR spectra. These experiments provide a census of the hydrogen and carbon atoms in unique chemical environments.

**Expert Insight:** The chemical shifts ( $\delta$ ) are highly diagnostic. For the piperidine ring, protons in an axial orientation are typically shielded (appear at a lower ppm) compared to their equatorial counterparts. The bulky 2,6-dimethoxyphenyl group will cause significant shielding of adjacent protons.

Experimental Protocol: 1D NMR Acquisition

- **Sample Preparation:** Dissolve approximately 5-10 mg of the purified compound in ~0.6 mL of a deuterated solvent (e.g., CDCl<sub>3</sub>, DMSO-d<sub>6</sub>).
- **Instrumentation:** Utilize a high-field NMR spectrometer (e.g., 400 MHz or higher) for optimal signal dispersion.
- **<sup>1</sup>H NMR Acquisition:** Acquire the spectrum using a standard pulse program. Key parameters include a sufficient number of scans for a good signal-to-noise ratio and a relaxation delay (d1) of at least 1-2 seconds.
- **<sup>13</sup>C NMR Acquisition:** Use a proton-decoupled pulse sequence. A DEPT (Distortionless Enhancement by Polarization Transfer) experiment is highly recommended to differentiate between CH<sub>3</sub>, CH<sub>2</sub>, CH, and quaternary carbons.

Table 1: Predicted <sup>1</sup>H and <sup>13</sup>C NMR Chemical Shifts for **2-(2,6-Dimethoxyphenyl)-1-methylpiperidine**

Assignment	Predicted <sup>1</sup> H Shift (ppm)	Predicted <sup>13</sup> C Shift (ppm)	Notes
N-CH <sub>3</sub>	~2.3 - 2.5	~42 - 46	Singlet, characteristic of N-methyl groups.
Piperidine H-2	~3.0 - 3.4	~60 - 65	Methine proton, coupling pattern reveals stereochemistry.
Piperidine H-3, H-4, H-5	~1.4 - 1.9	~24 - 35	Complex multiplets in the aliphatic region.
Piperidine H-6	~2.1 - 2.8	~55 - 60	Diastereotopic protons adjacent to nitrogen.
O-CH <sub>3</sub>	~3.8 - 3.9	~55 - 56	Two distinct singlets due to hindered rotation or slight electronic differences.
Aromatic H-3', H-5'	~6.5 - 6.7	~104 - 106	Doublet, shielded by methoxy groups.
Aromatic H-4'	~7.1 - 7.3	~128 - 130	Triplet, deshielded relative to H-3'/H-5'.
Aromatic C-1'	N/A	~130 - 135	Quaternary carbon, attached to piperidine.
Aromatic C-2', C-6'	N/A	~157 - 159	Quaternary carbons, attached to methoxy groups.

## 2D NMR: Assembling the Molecular Puzzle

Two-dimensional NMR experiments are essential for unambiguously assigning the signals from 1D spectra and establishing the complete bonding network.

- COSY (Correlation Spectroscopy): Identifies protons that are coupled to each other (typically through 2-3 bonds). This is used to trace the proton-proton connectivity around the piperidine ring.
- HSQC (Heteronuclear Single Quantum Coherence): Correlates each proton signal with the signal of the carbon to which it is directly attached. This provides a definitive link between the  $^1\text{H}$  and  $^{13}\text{C}$  assignments.
- HMBC (Heteronuclear Multiple Bond Correlation): Reveals correlations between protons and carbons over longer ranges (2-4 bonds). This is critical for connecting disparate parts of the molecule, such as linking the N-methyl protons to carbons C-2 and C-6 of the piperidine ring, and linking the piperidine H-2 proton to the aromatic C-1' carbon.

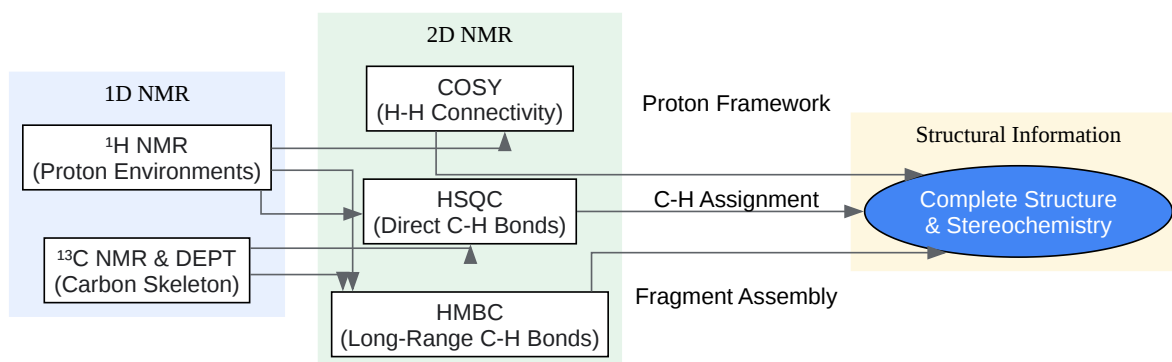

[Click to download full resolution via product page](#)

Caption: NMR workflow for structure elucidation.

## Conformational Analysis and Stereochemistry

The piperidine ring typically adopts a low-energy chair conformation.<sup>[2][7][8]</sup> The orientation of the bulky 2-aryl substituent is a key stereochemical feature.

Expert Insight: Due to allylic strain ( $A^{1,3}$  strain) between the N-methyl group and the substituent at C-2, the 2-(2,6-dimethoxyphenyl) group is expected to preferentially occupy the axial position to minimize steric repulsion.<sup>[5][6]</sup> This can be confirmed by analyzing the coupling constants of the H-2 proton. An axial H-2 proton will exhibit large axial-axial couplings (~10-13 Hz) to the axial protons on C-3 and a smaller axial-equatorial coupling.

Nuclear Overhauser Effect (NOE) experiments (NOESY or ROESY) can provide definitive proof of through-space proximity, confirming the axial orientation by showing correlations between the H-2 proton and the axial protons at C-4 and C-6.

## Mass Spectrometry (MS): Molecular Weight and Fragmentation

Mass spectrometry is a crucial complementary technique that provides the molecular weight of the compound and offers structural clues through analysis of its fragmentation patterns.

### Ionization Techniques: EI vs. ESI

- Electrospray Ionization (ESI): This is a "soft" ionization technique that typically results in the protonated molecule,  $[M+H]^+$ .<sup>[1][9]</sup> It is the method of choice for accurate mass measurement to determine the elemental formula.
- Electron Ionization (EI): This is a "hard" ionization technique that causes extensive fragmentation. The fragmentation pattern serves as a molecular fingerprint.<sup>[1]</sup>

### Fragmentation Pathways

For N-methylpiperidines, the most characteristic fragmentation pathway under EI is  $\alpha$ -cleavage, which involves the cleavage of the C-C bond adjacent to the nitrogen atom.<sup>[1]</sup> This results in the formation of a resonance-stabilized iminium ion.

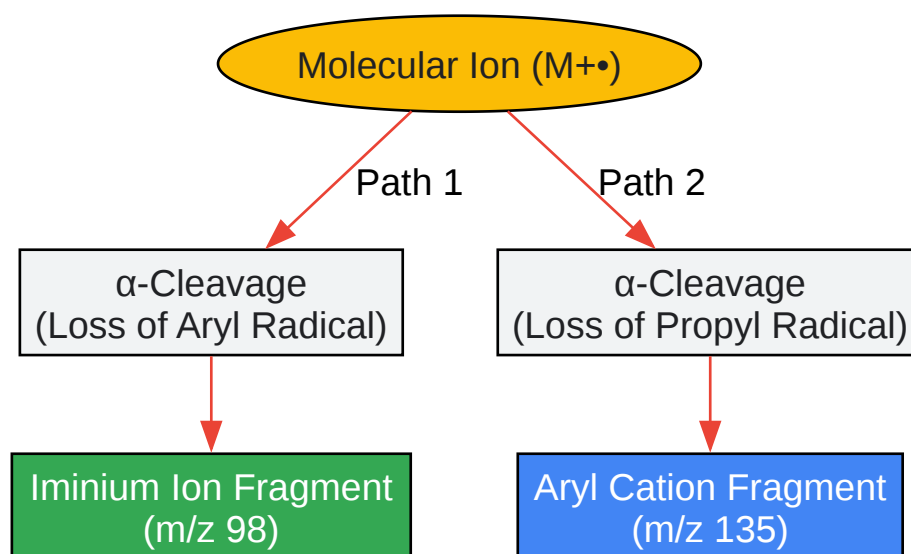

[Click to download full resolution via product page](#)

Caption: Key fragmentation pathways in EI-MS.

Experimental Protocol: LC-MS Analysis

- Sample Preparation: Prepare a dilute solution of the compound (~1 mg/mL) in a suitable solvent like methanol or acetonitrile.
- LC Separation: Inject the sample onto a liquid chromatograph (LC) system, typically with a C18 column, to ensure sample purity before MS analysis.
- MS Detection:
  - Ionization: Use an ESI source in positive ion mode.
  - Full Scan: Perform a full scan (e.g., m/z 100-500) to identify the  $[M+H]^+$  precursor ion.
  - MS/MS: Perform a product ion scan on the precursor ion to observe its fragmentation pattern. Optimize collision energy to obtain a rich spectrum of fragment ions.[1]

Table 2: Expected Mass Spectrometry Data

Ion	m/z (Expected)	Technique	Notes
[M+H] <sup>+</sup>	250.1807	ESI (HRMS)	Corresponds to the protonated molecule, C <sub>15</sub> H <sub>24</sub> NO <sub>2</sub> <sup>+</sup> .
[M] <sup>+•</sup>	249	EI	Molecular ion peak.
[M - C <sub>8</sub> H <sub>9</sub> O <sub>2</sub> ] <sup>+</sup>	98	EI	Result of α-cleavage, loss of the dimethoxyphenyl radical. Characteristic N-methylpiperidine iminium ion.
[C <sub>8</sub> H <sub>9</sub> O <sub>2</sub> ] <sup>+</sup>	137	EI	Dimethoxyphenyl fragment.

## X-ray Crystallography: The Definitive Structure

When a suitable single crystal can be grown, X-ray crystallography provides an unambiguous, three-dimensional model of the molecule in the solid state.<sup>[10][11]</sup> It is considered the gold standard for structural determination, confirming connectivity, stereochemistry, and the solid-state conformation.

**Expert Insight:** The crystal structure would definitively confirm the predicted axial conformation of the 2-aryl group and provide precise bond lengths and angles, revealing any distortions caused by steric strain.

### Experimental Protocol: Single-Crystal X-ray Diffraction

- **Crystal Growth:** Grow single crystals of the compound. This is often the most challenging step and may require screening various solvents and techniques (e.g., slow evaporation, vapor diffusion).
- **Data Collection:** Mount a suitable crystal on a goniometer in an X-ray diffractometer. Cool the crystal (typically to 100 K) to minimize thermal vibrations and collect diffraction data.

- Structure Solution and Refinement: Process the diffraction data to solve the phase problem and generate an initial electron density map. Refine the atomic positions and thermal parameters to obtain the final crystal structure.

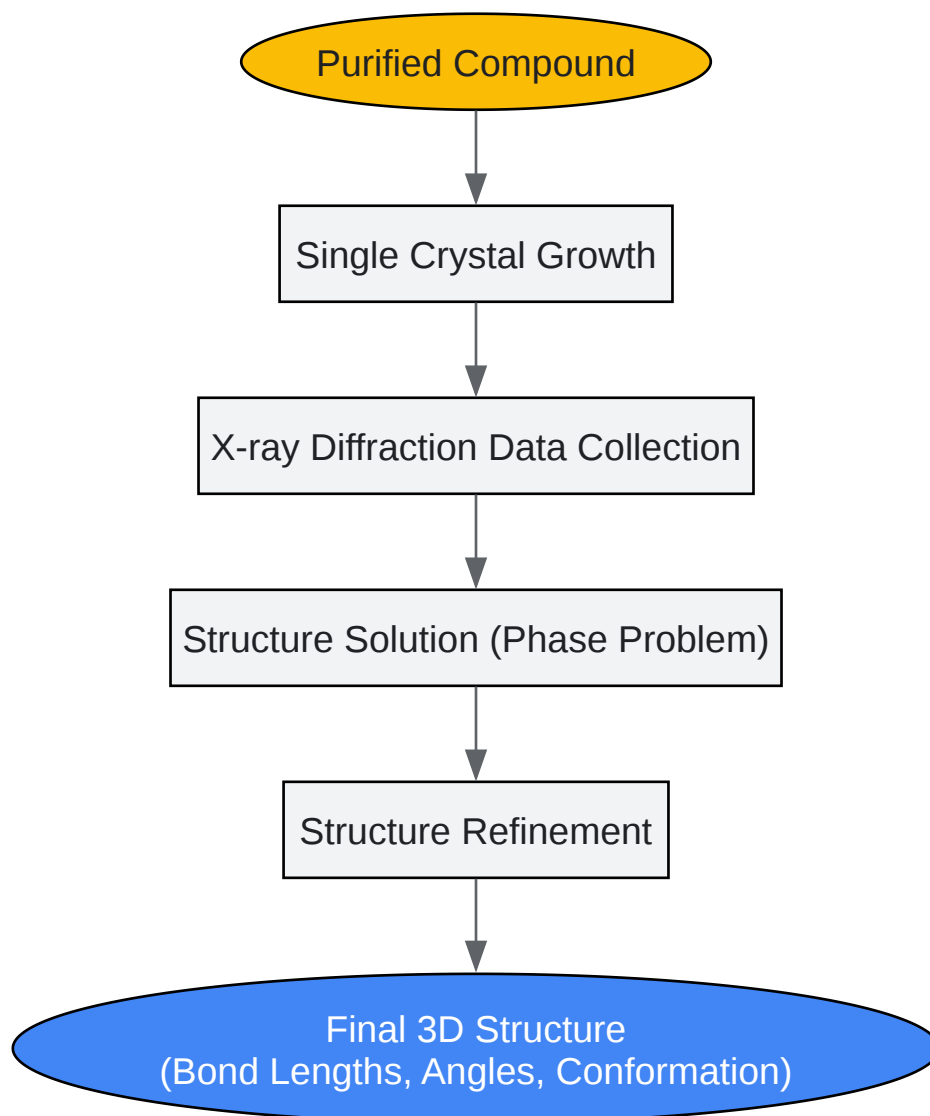

[Click to download full resolution via product page](#)

Caption: Workflow for X-ray crystallography.

## Conclusion: A Self-Validating Approach

The structure elucidation of **2-(2,6-dimethoxyphenyl)-1-methylpiperidine** is achieved through the logical and synergistic application of multiple analytical techniques. NMR spectroscopy establishes the molecular framework and provides deep insight into the solution-state

conformation. Mass spectrometry confirms the molecular formula and supports the proposed structure through predictable fragmentation. Finally, X-ray crystallography offers definitive, solid-state proof of the atomic arrangement. Each technique validates the others, creating a self-consistent and irrefutable structural assignment that is essential for advancing research and development in the chemical and pharmaceutical sciences.

## References

- Rubiralta, M., Luque, J., Orozco, M., Diez, A., & López, I. (1992). CONFORMATIONAL ANALYSIS OF 2-ARYL-4-PIPERIDONES. EFFECT OF THE INDOLE PROTECTIVE PHENYLSULFONYL GROUP. HETEROCYCLES, 34(3), 449. Available at: [\[Link\]](#)
- Barlow, R. B. (n.d.). The X-Ray Crystal Structure of 4-Diphenylcarbonyl-N-Methylpiperidine Methobromide. Amanote Research. Available at: [\[Link\]](#)
- Freitas, C. S., et al. (2019). Mass spectrometry for characterization of homologous piperidine alkaloids and their activity as acetylcholinesterase inhibitors. ResearchGate. Available at: [\[Link\]](#)
- Coombs, T. C., et al. (2011). Use of A1,3 strain to control constitutional (2,4- vs. 2,5-Ar/Nu relationship), stereochemical (cis vs. trans), and conformational diversity in piperidine libraries. ResearchGate. Available at: [\[Link\]](#)
- Duffield, A. M., Budzikiewicz, H., & Djerassi, C. (1965). Mass Spectrometry in Structural and Stereochemical Problems. LXXII. A Study of the Fragmentation Processes of Some Tobacco Alkaloids. Journal of the American Chemical Society. Available at: [\[Link\]](#)
- Czarnecki, R., et al. (2003). Crystal structure and vibrational spectrum of N-methylpiperidine betaine hexafluorosilicate. ResearchGate. Available at: [\[Link\]](#)
- Zhu, Z., et al. (2022). Modulating Conformational Preferences by Allylic Strain toward Improved Physical Properties and Binding Interactions. Journal of Medicinal Chemistry. Available at: [\[Link\]](#)
- Thangamani, A., et al. (2007). Conformation of hindered piperidines: Spectroscopic evidence for contribution of boat conformations. Journal of Chemical Sciences. Available at: [\[Link\]](#)

- Tiekink, E. R. T., & Zukerman-Schpector, J. (2016). Crystal structures of two alanyl piperidine analogues. Acta Crystallographica Section E: Crystallographic Communications. Available at: [\[Link\]](#)
- Jones, P. G., & Ahrens, B. (2024). Crystal structures of five gold(I) complexes with methylpiperidine ligands. IUCr Journals. Available at: [\[Link\]](#)
- Deng, G., et al. (2016). Conformational analysis of 2-substituted piperazines. Bioorganic & Medicinal Chemistry Letters. Available at: [\[Link\]](#)
- Revathi, B. K., et al. (2015). Crystal structure of 4-methyl-N-[2-(piperidin-1-yl)ethyl]benzamide monohydrate. Acta Crystallographica Section E: Crystallographic Communications. Available at: [\[Link\]](#)
- Khaiitova, M., et al. (2022). Computer-aided evaluation of targets and biological activity spectra for new piperidine derivatives. Journal of Clinical Medicine of Kazakhstan. Available at: [\[Link\]](#)

### Need Custom Synthesis?

BenchChem offers custom synthesis for rare earth carbides and specific isotopic labeling.

Email: [info@benchchem.com](mailto:info@benchchem.com) or [Request Quote Online](#).

## Sources

- [1. benchchem.com](https://www.benchchem.com) [[benchchem.com](https://www.benchchem.com)]
- [2. ias.ac.in](https://ias.ac.in) [[ias.ac.in](https://ias.ac.in)]
- [3. Journal of Clinical Medicine of Kazakhstan](https://www.clinmedkaz.org) [[clinmedkaz.org](https://www.clinmedkaz.org)]
- [4. triggered.stanford.clockss.org](https://triggered.stanford.clockss.org) [[triggered.stanford.clockss.org](https://triggered.stanford.clockss.org)]
- [5. researchgate.net](https://www.researchgate.net) [[researchgate.net](https://www.researchgate.net)]
- [6. Modulating Conformational Preferences by Allylic Strain toward Improved Physical Properties and Binding Interactions - PMC](https://pubmed.ncbi.nlm.nih.gov) [[pmc.ncbi.nlm.nih.gov](https://pubmed.ncbi.nlm.nih.gov)]
- [7. researchgate.net](https://www.researchgate.net) [[researchgate.net](https://www.researchgate.net)]

- [8. Crystal structure of 4-methyl-N-\[2-\(piperidin-1-yl\)ethyl\]benzamide monohydrate - PMC \[pmc.ncbi.nlm.nih.gov\]](#)
- [9. researchgate.net \[researchgate.net\]](#)
- [10. Crystal structures of two alanyl piperidine analogues - PMC \[pmc.ncbi.nlm.nih.gov\]](#)
- [11. journals.iucr.org \[journals.iucr.org\]](#)
- To cite this document: BenchChem. [Nuclear Magnetic Resonance (NMR) Spectroscopy: The Cornerstone of Structural Analysis]. BenchChem, [2026]. [Online PDF]. Available at: [<https://www.benchchem.com/product/b11805639/docs#nuclear-magnetic-resonance-nmr-spectroscopy-the-cornerstone-of-structural-analysis>]

---

### Disclaimer & Data Validity:

The information provided in this document is for Research Use Only (RUO) and is strictly not intended for diagnostic or therapeutic procedures. While BenchChem strives to provide accurate protocols, we make no warranties, express or implied, regarding the fitness of this product for every specific experimental setup.

**Technical Support:** The protocols provided are for reference purposes. Unsure if this reagent suits your experiment?

**Need Industrial/Bulk Grade?** [Request Custom Synthesis Quote](#)

## BenchChem

Our mission is to be the trusted global source of essential and advanced chemicals, empowering scientists and researchers to drive progress in science and industry.

### Contact

Address: 3281 E Guasti Rd  
Ontario, CA 91761, United States  
Phone: (601) 213-4426  
Email: [info@benchchem.com](mailto:info@benchchem.com)

Contact our Ph.D. Support Team for a compatibility check