

# Technical Support Center: Chloropyrrolopyrazine Coupling Optimization

**Author:** BenchChem Technical Support Team. **Date:** May 2026

## Compound of Interest

Compound Name: *7-Chloro-5H-pyrrolo[2,3-  
b]pyrazine*

Cat. No.: *B11804581*

[Get Quote](#)

Topic: Optimizing Reaction Temperature for Chloropyrrolopyrazine Coupling Target Audience: Medicinal Chemists, Process Chemists, and Drug Development Scientists Reference ID: CPP-OPT-2024-v1

## Introduction

Welcome to the Technical Support Center. You are likely here because you are working with a pyrrolo[2,3-*b*]pyrazine scaffold—a privileged structure in kinase inhibitor development (e.g., Upadacitinib).

The coupling of 2-chloropyrrolo[2,3-*b*]pyrazine derivatives is a critical but temperamental step. The electron-deficient pyrazine ring activates the chlorine towards Nucleophilic Aromatic Substitution (

), while the fused pyrrole ring introduces electron density that can complicate reactivity and stability.

This guide moves beyond generic advice, focusing on the thermodynamic and kinetic levers you can pull to optimize this specific transformation.

## Module 1: The Thermodynamics of Coupling

### The "Goldilocks" Zone

Temperature optimization for this scaffold is rarely about "cranking it up" to drive conversion. It is a balancing act between three competing pathways:

- Product Formation ( ): The desired or Pd-catalyzed cross-coupling.
- Dehalogenation/Hydrolysis ( ): The 2-chloro position is sensitive to hydrolysis in wet solvents at high temperatures ( ), converting to the inactive 2-oxo species.
- Oligomerization ( ): If the pyrrole nitrogen is unprotected, high temperatures facilitate self-coupling or N-alkylation side reactions.

### Mechanism & Temperature Influence

The following diagram illustrates the kinetic vs. thermodynamic control points in the reaction pathway.

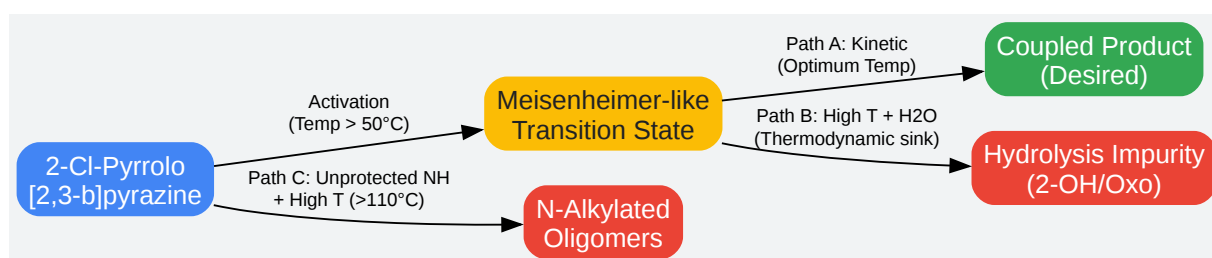

[Click to download full resolution via product page](#)

Figure 1: Reaction pathways for chloropyrrolopyrazine coupling. Path A is the target. Path B and C become dominant when temperature exceeds the stability threshold of the intermediate.

## Module 2: Troubleshooting Guide

Use this matrix to diagnose issues based on your reaction's thermal profile.

### Symptom: Reaction Stalls at ~60% Conversion

Root Cause	Diagnostic	Solution
Catalyst Deactivation (Pd-coupling)	Reaction turns black (Pd precipitation) rapidly at .	Lower Temp & Change Ligand. Switch to a bulky, electron-rich phosphine (e.g., XPhos, BrettPhos) that is active at .
Product Inhibition ( )	Product precipitates or coordinates to the nucleophile.	Solvent Switch. Move to high-boiling polar aprotic solvents (DMSO, NMP) to maintain solubility, allowing lower reaction temps ( vs ).

### Symptom: Appearance of "Hydroxy" Impurity (M-18 or M-Cl+OH)

Root Cause	Diagnostic	Solution
Wet Solvent + High Temp	LCMS shows peak with mass corresponding to hydrolysis (2-oxo derivative).	Strict Anhydrous Protocol. The chloropyrazine bond is labile to hydrolysis above  . Dry solvents over molecular sieves. Reduce temp by  .
Base-Mediated Hydrolysis	Using hygroscopic bases (KOH, NaOH) at reflux.	Switch Base. Use non-nucleophilic, anhydrous bases like  or DIPEA.

## Symptom: Multiple Spots on TLC (Regioisomers)

Root Cause	Diagnostic	Solution
Loss of Kinetic Control	Occurs in di-halo scaffolds (e.g., 2,6-dichloro). Both halogens react at high temp.	Cryogenic Start. Initiate reaction at  or  to favor the more electron-deficient position (Kinetic Control), then slowly warm to RT.

## Module 3: Optimized Experimental Protocol

This protocol is based on the synthesis of JAK inhibitor intermediates (e.g., Upadacitinib), prioritizing regioselectivity and purity over raw speed.

Objective:

Coupling of amine to 2-chloro-5-tosyl-5H-pyrrolo[2,3-b]pyrazine.

## Workflow Diagram

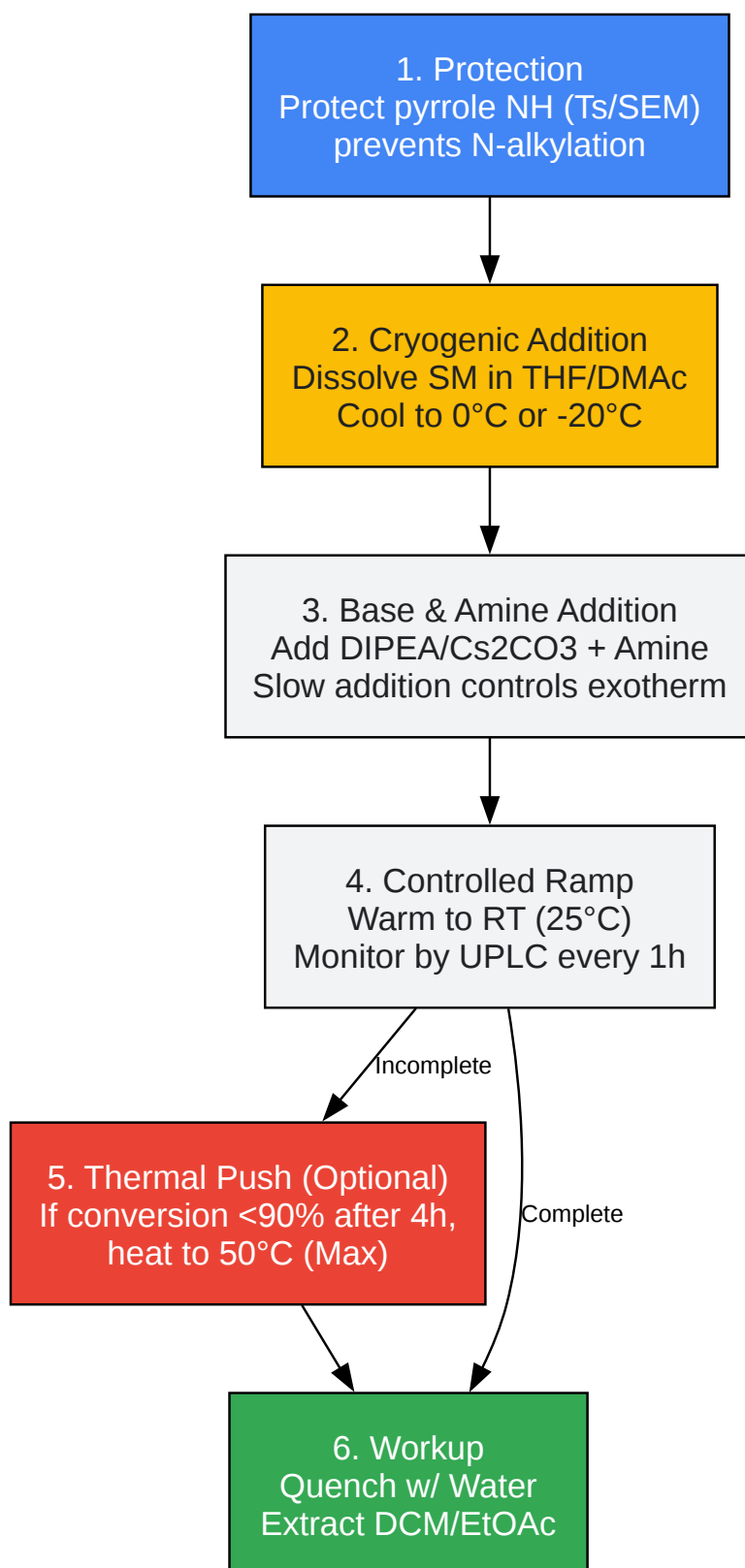

[Click to download full resolution via product page](#)

Figure 2: Step-by-step optimization workflow for chloropyrrolopyrazine coupling.

## Detailed Procedure

- Preparation: Charge a reaction vessel with 2-chloro-5-tosyl-5H-pyrrolo[2,3-b]pyrazine (1.0 equiv).
  - Note: The tosyl group is crucial. Unprotected substrates require significantly higher temperatures ( ) and yield messy profiles due to competing NH reactivity.
- Solvation: Add anhydrous DMAc (Dimethylacetamide) or THF (10 V).
- Temperature Set: Cool the mixture to .
  - Why? Even for mono-chloro substrates, initiating cold suppresses initial exotherms and degradation [1].
- Reagent Addition: Add the amine nucleophile (1.1–1.5 equiv) followed by (2.0 equiv) or DIPEA.
- Reaction: Stir at for 1 hour, then allow to warm to .
- Monitoring: Check conversion after 4 hours.
  - Decision Gate: If conversion is , heat to . Do not exceed with strong bases to avoid tosyl cleavage or hydrolysis.

## Module 4: Frequently Asked Questions (FAQ)

Q: Can I use microwave irradiation to speed this up? A: Use caution. While microwaves accelerate

kinetics, chloropyrrolopyrazines are prone to hydrolysis in superheated solvents. If you must use MW, limit the temperature to

and use strictly anhydrous solvents (e.g., dry NMP).

Q: My reaction works in n-Butanol at reflux (

) but the yield is variable. Why? A: n-Butanol is a classic solvent for these couplings, but

is often near the "thermal ceiling" for this scaffold. Variable yields usually indicate inconsistent water content in the n-BuOH, leading to hydrolysis. Switch to DMSO or DMAc at

for a more controllable profile [2].

Q: I have a 2,6-dichloro scaffold. How do I couple selectively at C-2? A: Temperature is your primary control. The C-2 position is generally more electrophilic due to the adjacent pyrazine nitrogen. Perform the reaction at

to RT. Heating to

will promote reaction at C-6 (the pyrrole side) or double addition [3].

## References

- Technical Disclosure Commons. (2022). Improved Process for the Preparation of Upadacitinib and its Intermediates.[1] (Defines low-temperature protocols for tosyl-protected intermediates).
- Organic Process Research & Development. (2019). Development of a Scalable Synthesis of Upadacitinib. (Discusses solvent effects and thermal stability of the pyrrolopyrazine core).
- National Institutes of Health (PMC). (2026). C2-Selective Palladium-Catalyzed C—S Cross-Coupling of 2,4-Dihalopyrimidines.[2] (Analogous chemistry demonstrating temperature-dependent regioselectivity in fused pyrimidines/pyrazines).
- Purdue University. (2022). Potential Safety Hazards Associated with Pd-Catalyzed Cross-Coupling Reactions.[3] (Safety data on exotherms in polar aprotic solvents).

### Need Custom Synthesis?

BenchChem offers custom synthesis for rare earth carbides and specific isotopic labeling.

Email: [info@benchchem.com](mailto:info@benchchem.com) or [Request Quote Online](#).

## Sources

- [1. EP3845521A2 - Synthesis methods for upadacitinib and intermediate thereof - Google Patents \[patents.google.com\]](#)
- [2. C2-Selective Palladium-Catalyzed C—S Cross-Coupling of 2,4-Dihalopyrimidines - PMC \[pmc.ncbi.nlm.nih.gov\]](#)
- [3. engineering.purdue.edu \[engineering.purdue.edu\]](#)
- To cite this document: BenchChem. [Technical Support Center: Chloropyrrolopyrazine Coupling Optimization]. BenchChem, [2026]. [Online PDF]. Available at: [\[https://www.benchchem.com/product/b11804581/docs#technical-support-center-chloropyrrolopyrazine-coupling-optimization\]](https://www.benchchem.com/product/b11804581/docs#technical-support-center-chloropyrrolopyrazine-coupling-optimization)

---

### Disclaimer & Data Validity:

The information provided in this document is for Research Use Only (RUO) and is strictly not intended for diagnostic or therapeutic procedures. While BenchChem strives to provide accurate protocols, we make no warranties, express or implied, regarding the fitness of this product for every specific experimental setup.

**Technical Support:** The protocols provided are for reference purposes. Unsure if this reagent suits your experiment?

**Need Industrial/Bulk Grade?** [Request Custom Synthesis Quote](#)

# BenchChem

Our mission is to be the trusted global source of essential and advanced chemicals, empowering scientists and researchers to drive progress in science and industry.

## Contact

Address: 3281 E Guasti Rd

Ontario, CA 91761, United States

Phone: (601) 213-4426

Email: [info@benchchem.com](mailto:info@benchchem.com)

[Contact our Ph.D. Support Team for a compatibility check](#)