

Technical Support Center: Synthesis of Pyrazolo[5,1-b]oxazoles

Author: BenchChem Technical Support Team. **Date:** April 2026

Compound of Interest

Compound Name: *Ethyl 3-methylpyrazolo[5,1-b]oxazole-6-carboxylate*

Cat. No.: *B11802126*

[Get Quote](#)

Welcome to the Technical Support Center for the synthesis of pyrazolo[5,1-b]oxazoles. This guide is designed for researchers, scientists, and professionals in drug development who are working with this important heterocyclic scaffold. Here, you will find troubleshooting advice and frequently asked questions (FAQs) to help you navigate the common challenges and side reactions encountered during the synthesis of these compounds. Our goal is to provide you with the technical insights and practical solutions needed to optimize your synthetic routes, improve yields, and ensure the purity of your target molecules.

Introduction to Pyrazolo[5,1-b]oxazole Synthesis

The synthesis of pyrazolo[5,1-b]oxazoles typically involves the cyclocondensation of an aminopyrazole with a β -dicarbonyl compound or a related 1,3-dielectrophile. A common starting material is 3-amino-5-methylpyrazole, which possesses two nucleophilic centers: the endocyclic N1 nitrogen and the exocyclic NH₂ group. This dual reactivity is the primary source of challenges in regioselectivity, often leading to the formation of undesired isomers.

The reaction of 5-aminopyrazoles with various bielectrophilic moieties is a widely used method for the synthesis of fused pyrazoloazines.^[1] However, controlling the reaction pathway to

selectively obtain the desired pyrazolo[5,1-b]oxazole isomer requires careful consideration of the reaction conditions and the nature of the substrates.

Troubleshooting Guide & FAQs

This section addresses specific issues that you may encounter during the synthesis of pyrazolo[5,1-b]oxazoles.

FAQ 1: My reaction is producing a mixture of isomers. How can I identify the desired pyrazolo[5,1-b]oxazole and the common isomeric side product?

Answer:

The most common side reaction in the synthesis of pyrazolo[5,1-b]oxazoles from 3-aminopyrazoles and β -dicarbonyl compounds is the formation of the isomeric pyrazolo[1,5-a]pyrimidine. This occurs due to the two possible modes of cyclization.

Mechanism of Isomer Formation:

The reaction begins with the initial condensation of the 3-aminopyrazole with one of the carbonyl groups of the β -dicarbonyl compound. The subsequent intramolecular cyclization can proceed via two pathways:

- Pathway A (Desired): The exocyclic amino group attacks the second carbonyl group, leading to the formation of the pyrazolo[5,1-b]oxazole ring.
- Pathway B (Side Reaction): The endocyclic pyrazole nitrogen (N1) attacks the second carbonyl group, resulting in the formation of the isomeric pyrazolo[1,5-a]pyrimidine. The condensation of 5-aminopyrazoles with 1,3-dicarbonyl compounds is a well-established route to pyrazolo[1,5-a]pyrimidines.[\[2\]](#)[\[3\]](#)[\[4\]](#)

Visualizing the Reaction Pathways:

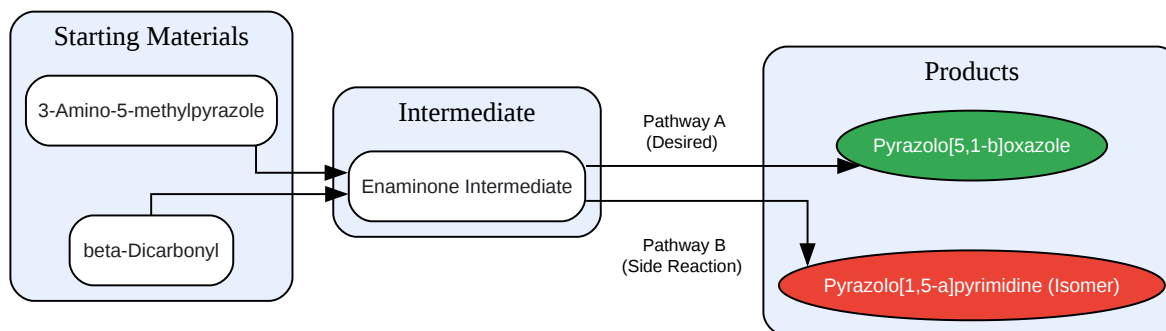

[Click to download full resolution via product page](#)

Caption: Reaction pathways leading to the desired product and an isomeric side product.

Identification and Characterization:

A combination of chromatographic and spectroscopic techniques is essential for distinguishing between the two isomers.

- Thin-Layer Chromatography (TLC): The two isomers will likely have different polarities and thus different R_f values. This can be used for initial reaction monitoring and for optimizing purification conditions.
- Nuclear Magnetic Resonance (NMR) Spectroscopy:
 - ^1H NMR: The chemical shifts and coupling patterns of the protons on the newly formed ring will be distinct for each isomer. Careful analysis of 2D NMR spectra (COSY, HSQC, HMBC) can help in the unambiguous assignment of the structure.
 - ^{13}C NMR: The chemical shifts of the carbons in the heterocyclic core will also differ significantly between the two isomers.
- Mass Spectrometry (MS): While both isomers will have the same molecular weight, fragmentation patterns in techniques like GC-MS or LC-MS/MS might show differences that can aid in their identification.

FAQ 2: How can I control the regioselectivity of the reaction to favor the formation of the desired pyrazolo[5,1-b]oxazole?

Answer:

Controlling the regioselectivity is the key to a successful synthesis. The outcome of the reaction is highly dependent on the reaction conditions.

Table 1: Influence of Reaction Conditions on Regioselectivity

Parameter	Condition Favoring Pyrazolo[5,1-b]oxazole (Pathway A)	Condition Favoring Pyrazolo[1,5-a]pyrimidine (Pathway B)	Rationale
Catalyst/Solvent	Acidic conditions (e.g., acetic acid, p-TsOH)	Basic conditions (e.g., piperidine, K ₂ CO ₃)	In acidic media, the endocyclic N1 of the pyrazole ring is protonated, reducing its nucleophilicity and favoring the attack from the exocyclic amino group. ^[1] Conversely, basic conditions can deprotonate the N1-H, increasing its nucleophilicity.
Temperature	Lower temperatures may favor the kinetically controlled product.	Higher temperatures can lead to the thermodynamically more stable product, which is often the pyrazolo[1,5-a]pyrimidine.	
Substituents on β -Dicarbonyl	Sterically bulky substituents on the β -dicarbonyl compound can influence the approach of the aminopyrazole and may favor one pathway over the other.	Less sterically hindered β -dicarbonyls may lead to a mixture of products.	

Experimental Protocol for Promoting Pyrazolo[5,1-b]oxazole Formation:

This protocol is a general guideline and may require optimization for specific substrates.

- **Reactant Preparation:** In a round-bottom flask, dissolve 1 equivalent of 3-amino-5-methylpyrazole in glacial acetic acid.
- **Addition of Dicarbonyl:** Add 1.1 equivalents of the β -dicarbonyl compound to the solution.
- **Reaction:** Stir the mixture at room temperature or with gentle heating (e.g., 50-60 °C). Monitor the reaction progress by TLC.
- **Work-up:** Once the reaction is complete, pour the mixture into ice-water. The product may precipitate and can be collected by filtration. Alternatively, extract the product with a suitable organic solvent (e.g., ethyl acetate).
- **Purification:** Purify the crude product by column chromatography on silica gel, using a gradient of ethyl acetate in hexanes.

FAQ 3: I am getting a low yield of my desired product, and I see several other spots on my TLC plate. What are other possible side reactions?

Answer:

Besides the formation of the pyrazolo[1,5-a]pyrimidine isomer, other side reactions can occur, leading to a complex reaction mixture and low yields of the desired product.

- **Self-condensation of the β -dicarbonyl compound:** Under certain conditions, particularly with strong bases or high temperatures, β -dicarbonyl compounds can undergo self-condensation reactions.
- **Formation of Michael Adducts:** If the β -dicarbonyl compound is α,β -unsaturated, the aminopyrazole can act as a nucleophile in a Michael addition reaction, leading to open-chain adducts that may or may not cyclize. The reaction of 5-aminopyrazoles with α,β -unsaturated ketones can lead to the formation of pyrazolo[3,4-b]pyridines.^[5]
- **Decomposition:** Both the starting materials and the product can be sensitive to harsh reaction conditions (strong acids/bases, high temperatures), leading to decomposition and

the formation of tar-like materials.

Troubleshooting Low Yields and Multiple Side Products:

- Optimize Reaction Temperature: Start with milder conditions (e.g., room temperature) and gradually increase the temperature if the reaction is too slow.
- Choice of Catalyst: If acidic conditions are not effective, try a milder Lewis acid catalyst.
- Purity of Starting Materials: Ensure that your 3-aminopyrazole and β -dicarbonyl compound are pure. Impurities can lead to unexpected side reactions.
- Inert Atmosphere: If your substrates are sensitive to oxidation, perform the reaction under an inert atmosphere (e.g., nitrogen or argon).

Visualizing the Troubleshooting Process:

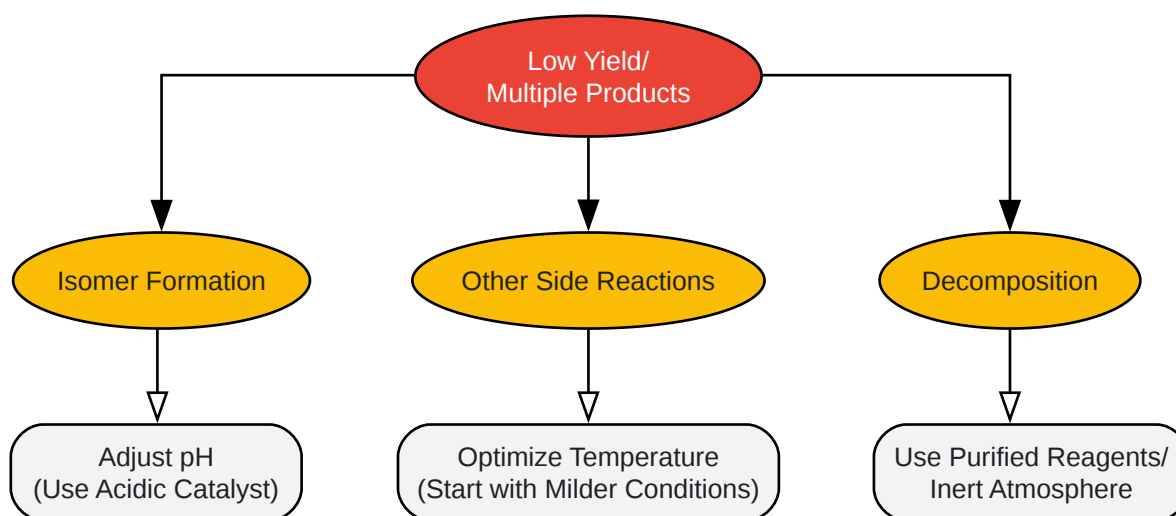

[Click to download full resolution via product page](#)

Caption: A decision tree for troubleshooting common issues in pyrazolo[5,1-b]oxazole synthesis.

References

- Convenient Synthesis of Pyrazolo[4',3':5,6]pyrano[4,3-c][6][7]oxazoles via Intramolecular Nitrile Oxide Cycloaddition. *Molecules*. 2021. [\[Link\]](#)

- Facile syntheses of novel benzo-1,3-dioxolo-, benzothiazolo-, pyrido-, and quinolino-fused 5H-benzo[d]-pyrazolo[5,1-b][5][6]-oxazines and 1H-pyrazoles. *Org Lett.* 2011. [[Link](#)]
- 1H-Pyrazolo[3,4-b]pyridines: Synthesis and Biomedical Applications. Daugavpils University. 2022. [[Link](#)]
- Multicomponent syntheses of pyrazoles via (3 + 2)-cyclocondensation and (3 + 2)-cycloaddition key steps. *Beilstein J Org Chem.* 2024. [[Link](#)]
- Different reaction pathways for the condensation of 5-aminopyrazoles, aldehydes, and 1,3-cyclic diketones. *Tetrahedron.* 2007. [[Link](#)]
- Highly facile and regio-selective synthesis of pyrazolo[1,5-a]pyrimidines via reactions of 1,2-allenic ketones with aminopyrazoles. *Org Biomol Chem.* 2014. [[Link](#)]
- Design, Synthesis, and Development of pyrazolo[1,5-a]pyrimidine Derivatives as a Novel Series of Selective PI3K δ Inhibitors: Part I—Indole Derivatives. *Molecules.* 2021. [[Link](#)]
- CONDENSATION OF 1-SUBSTITUTED 5-AMINOPYRAZOLES WITH β -DICARBONYL COMPOUNDS. *Chemistry of Heterocyclic Compounds.* 2003. [[Link](#)]
- Synthetic Strategy for Pyrazolo[1,5-a]pyridine and Pyrido[1,2-b]indazole Derivatives through AcOH and O₂-Promoted Cross-dehydrogenative Coupling Reactions between 1,3-Dicarbonyl Compounds and N-Amino-2-iminopyridines. *ACS Omega.* 2019. [[Link](#)]
- Synthesis, Characterization, and Biological Evaluation of Some Novel Pyrazolo[5,1-b]thiazole Derivatives as Potential Antimicrobial and Anticancer Agents. *Molecules.* 2021. [[Link](#)]
- Pyrazole Scaffold: Strategies toward the Synthesis and Their Applications. *IntechOpen.* 2022. [[Link](#)]
- Synthesis of some new pyrazolo[5,1-c][6][7][8]triazine derivatives and computational study. *Journal of Molecular Structure.* 2017. [[Link](#)]
- Regioselective Synthesis of Cycloalkane-fused Pyrazolo[4,3- e]pyridines through Tandem Reaction of 5-aminopyrazoles, Cyclic Ketones and Electron-rich Olefins. *Curr Org Synth.*

2024. [\[Link\]](#)

- 5-Aminopyrazole as precursor in design and synthesis of fused pyrazoloazines. RSC Adv. 2018. [\[Link\]](#)
- The synthesis of new pyrazolo[1,5-a]pyrimidine derivatives. ARKIVOC. 2008. [https://www.researchgate.net/publication/228514801_The_synthesis_of_new_pyrazolo15-a_pyrimidine_derivatives]([\[Link\]](#))
- Highly facile and regio-selective synthesis of pyrazolo[1,5-a]pyrimidines via reactions of 1,2-allenic ketones with aminopyrazoles. RSC Advances. 2014. [\[Link\]](#)
- The Recent Development of the Pyrazoles : A Review. TSI Journals. 2021. [\[Link\]](#)
- Synthesis of isoxazoles and their hydrazinolysis to 5-aminopyrazoles: an approach to fluorescent derivatives. RSC Adv. 2022. [\[Link\]](#)
- a]pyrimidine, Pyrazolo[5,1-b]quinazoline and Imidazo[1,2- b]pyrazole Derivatives Incorporating Phenylsulfonyl Moiety. Molecules. 2021. [\[Link\]](#)
- Synthesis of some new pyrazolo[1,5-a]pyrimidine, pyrazolo[5,1-c]triazine, 1,3,4-thiadiazole and pyridine derivatives containing 1,2,3-triazole moiety. Journal of the Chinese Chemical Society. 2018. [\[Link\]](#)
- A Mini-Review 5-Amino-N-Substituted Pyrazoles as Building Blocks for Bioactive Molecules. Open Journal of Medicinal Chemistry. 2018. [\[Link\]](#)
- Resonance structures of 3(5)-Amino-5(3)-methylpyrazole. ResearchGate. 2019. [\[Link\]](#)
- Recent developments in aminopyrazole chemistry. ARKIVOC. 2005. [\[Link\]](#)

Need Custom Synthesis?

BenchChem offers custom synthesis for rare earth carbides and specific isotopic labeling.

Email: info@benchchem.com or [Request Quote Online](#).

Sources

- 1. 5-Aminopyrazole as precursor in design and synthesis of fused pyrazoloazines - PMC [pmc.ncbi.nlm.nih.gov]
- 2. Design, Synthesis, and Development of pyrazolo[1,5-a]pyrimidine Derivatives as a Novel Series of Selective PI3K δ Inhibitors: Part I—Indole Derivatives - PMC [pmc.ncbi.nlm.nih.gov]
- 3. [researchgate.net](https://www.researchgate.net) [[researchgate.net](https://www.researchgate.net)]
- 4. [nanobioletters.com](https://www.nanobioletters.com) [[nanobioletters.com](https://www.nanobioletters.com)]
- 5. Multicomponent syntheses of pyrazoles via (3 + 2)-cyclocondensation and (3 + 2)-cycloaddition key steps - PMC [pmc.ncbi.nlm.nih.gov]
- 6. [mdpi.com](https://www.mdpi.com) [[mdpi.com](https://www.mdpi.com)]
- 7. Facile syntheses of novel benzo-1,3-dioxolo-, benzothiazolo-, pyrido-, and quinolino-fused 5H-benzo[d]-pyrazolo[5,1-b][1,3]-oxazines and 1H-pyrazoles - PubMed [pubmed.ncbi.nlm.nih.gov]
- 8. BJOC - Multicomponent syntheses of pyrazoles via (3 + 2)-cyclocondensation and (3 + 2)-cycloaddition key steps [beilstein-journals.org]
- To cite this document: BenchChem. [Technical Support Center: Synthesis of Pyrazolo[5,1-b]oxazoles]. BenchChem, [2026]. [Online PDF]. Available at: [<https://www.benchchem.com/product/b11802126/docs#technical-support-center-synthesis-of-pyrazolo-5-1-b-oxazoles>]

Disclaimer & Data Validity:

The information provided in this document is for Research Use Only (RUO) and is strictly not intended for diagnostic or therapeutic procedures. While BenchChem strives to provide accurate protocols, we make no warranties, express or implied, regarding the fitness of this product for every specific experimental setup.

Technical Support: The protocols provided are for reference purposes. Unsure if this reagent suits your experiment?

Need Industrial/Bulk Grade? [Request Custom Synthesis Quote](#)

BenchChem

Our mission is to be the trusted global source of essential and advanced chemicals, empowering scientists and researchers to drive progress in science and industry.

Contact

Address: 3281 E Guasti Rd

Ontario, CA 91761, United States

Phone: (601) 213-4426

Email: info@benchchem.com

[Contact our Ph.D. Support Team for a compatibility check](#)