

# Transcriptional Regulation of the TYK2 Gene: An In-depth Technical Guide

**Author:** BenchChem Technical Support Team. **Date:** April 2026

## Compound of Interest

Compound Name: *tyk2 protein*  
CAS No.: 132966-45-1  
Cat. No.: B1180145

[Get Quote](#)

For Researchers, Scientists, and Drug Development Professionals

## Introduction

Tyrosine kinase 2 (TYK2), a member of the Janus kinase (JAK) family, is a critical intracellular mediator of cytokine signaling. It plays a pivotal role in the signal transduction of various cytokines, including type I interferons (IFNs), interleukin (IL)-12, and IL-23, which are essential for both innate and adaptive immunity.[1][2] Dysregulation of TYK2 expression and activity is implicated in the pathogenesis of numerous autoimmune diseases and cancers, making it a key therapeutic target.[3] Understanding the intricate mechanisms that govern the transcriptional regulation of the TYK2 gene is paramount for the development of novel and specific therapeutic strategies. This technical guide provides a comprehensive overview of the core aspects of TYK2 gene regulation, including key signaling pathways, transcription factors, and regulatory elements. It also offers detailed methodologies for essential experiments and presents quantitative data in a structured format to facilitate research and drug development efforts.

# Core Signaling Pathways Regulating TYK2 Transcription

The expression of the TYK2 gene is tightly controlled by a network of signaling pathways initiated by various cytokines. These pathways converge on the activation of specific transcription factors that directly or indirectly modulate TYK2 gene transcription.

## Type I Interferon (IFN- $\alpha/\beta$ ) Signaling

Type I interferons are potent antiviral and immunomodulatory cytokines that signal through a receptor complex associated with TYK2 and JAK1.[4] Upon ligand binding, this association leads to the phosphorylation and activation of Signal Transducer and Activator of Transcription (STAT) proteins, primarily STAT1 and STAT2.[4] These activated STATs form a heterodimer, which then associates with Interferon Regulatory Factor 9 (IRF9) to form the ISGF3 complex. This complex translocates to the nucleus and binds to Interferon-Stimulated Response Elements (ISREs) in the promoters of target genes, including potentially the TYK2 gene itself, to drive their transcription.[4]

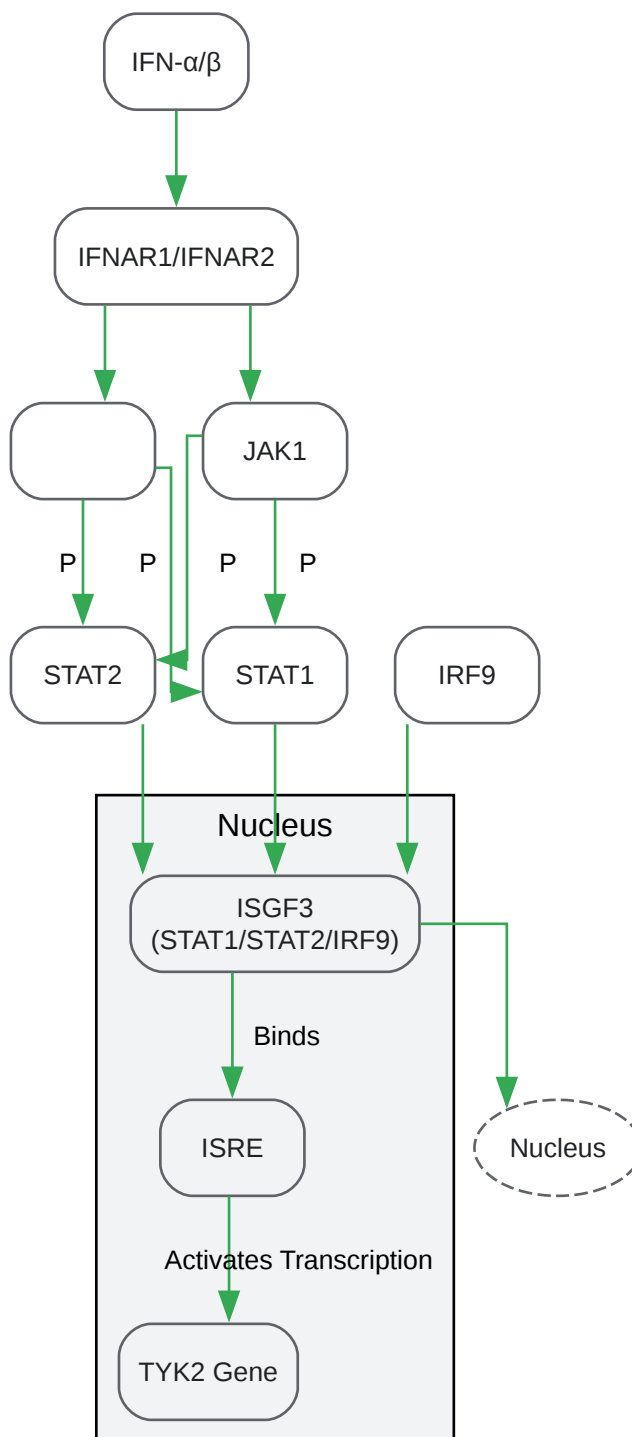

[Click to download full resolution via product page](#)

Type I Interferon Signaling Pathway leading to TYK2 Transcription.

## Interleukin-12 (IL-12) Signaling

IL-12 is a key cytokine in the differentiation of T helper 1 (Th1) cells and the production of IFN- $\gamma$ . Its receptor is associated with TYK2 and JAK2.[2][5] Binding of IL-12 to its receptor leads to the activation of TYK2 and JAK2, which in turn phosphorylate and activate STAT4.[5] Activated STAT4 translocates to the nucleus and binds to specific DNA elements in the promoters of target genes, potentially including the TYK2 gene, to regulate their expression.

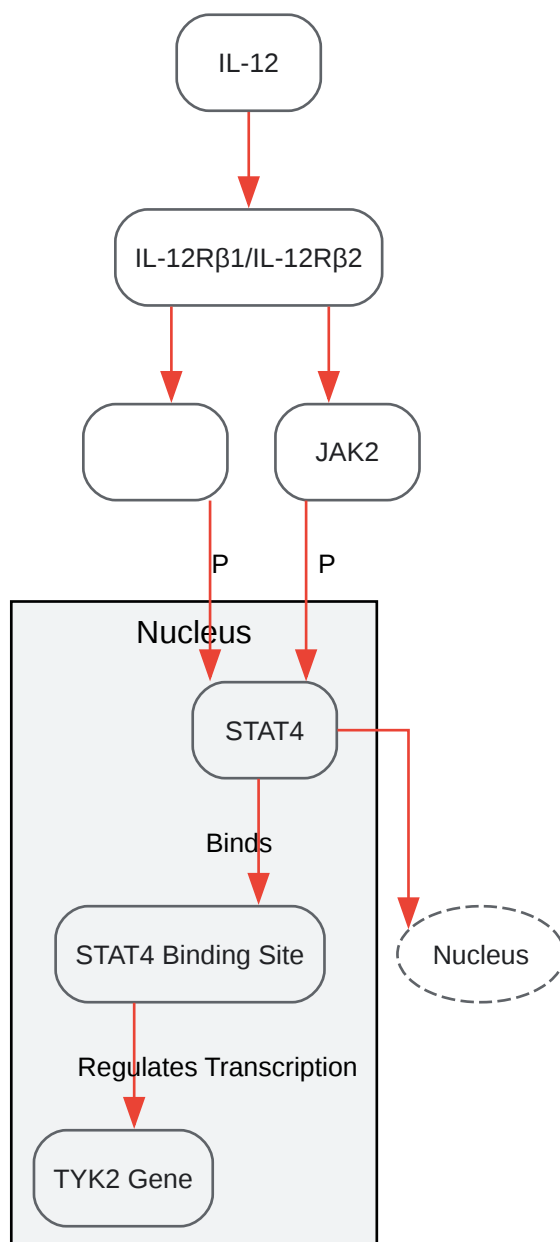

[Click to download full resolution via product page](#)

IL-12 Signaling Pathway and its potential influence on TYK2 Transcription.

## Interleukin-23 (IL-23) Signaling

IL-23 is crucial for the maintenance and expansion of Th17 cells, which are involved in several autoimmune diseases. The IL-23 receptor also utilizes the TYK2/JAK2 kinase pair for signal transduction.[6][7] Upon IL-23 binding, TYK2 and JAK2 are activated and subsequently phosphorylate STAT3.[8] Activated STAT3 translocates to the nucleus and binds to specific DNA response elements to regulate the transcription of target genes, which may include TYK2.

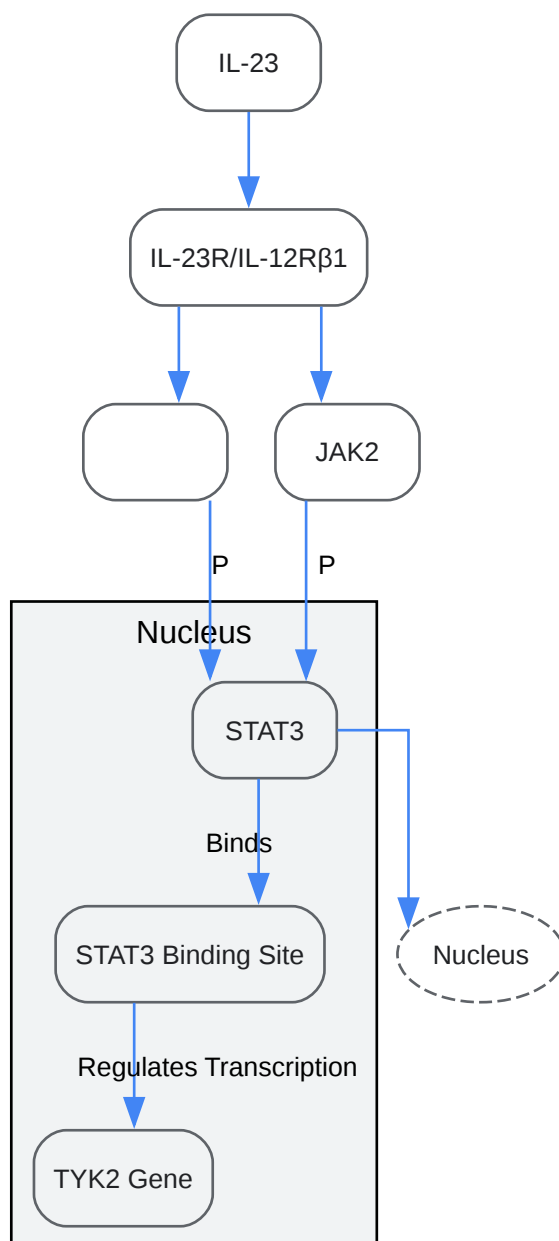

[Click to download full resolution via product page](#)

IL-23 Signaling Pathway potentially impacting TYK2 Transcription.

## Key Transcription Factors and Regulatory Elements

The transcriptional regulation of the TYK2 gene is orchestrated by a cohort of transcription factors that bind to specific regulatory elements, such as promoters and enhancers, within the gene's locus.

### Transcription Factors

Several transcription factors have been predicted or experimentally shown to be involved in the regulation of TYK2 gene expression.

Transcription Factor	Predicted/Validated	Role in TYK2 Regulation	Key Signaling Pathway
STAT1	Validated	Activates transcription in response to IFN- $\alpha$ / $\beta$ and IL-12.[4][5]	Type I Interferon, IL-12
STAT2	Validated	Component of the ISGF3 complex, activating transcription in response to IFN- $\alpha$ / $\beta$ . [4]	Type I Interferon
STAT3	Validated	Activates transcription in response to IL-23 and other cytokines. [8][9]	IL-23, IL-10
STAT4	Validated	Mediates transcriptional activation in response to IL-12.[5]	IL-12
STAT5A	Predicted	Potential regulator of TYK2 expression.[9]	Various Cytokines
IRF1	Predicted	May contribute to IFN-inducible expression.	Type I Interferon
NF- $\kappa$ B	Predicted	Potential involvement in inflammatory responses.	TNF- $\alpha$ , IL-1 $\beta$
AhR	Predicted	Potential role in response to environmental stimuli. [9]	Aryl hydrocarbon receptor
YY1	Predicted	A ubiquitous transcription factor that can act as an	General Transcription

activator or repressor.

[9]

## Regulatory Elements

The TYK2 gene locus contains several regulatory elements that are crucial for the precise control of its transcription.

- **Promoter:** The core promoter region of the TYK2 gene contains binding sites for various transcription factors, including STATs, which are essential for initiating transcription.
- **Enhancers:** Distal enhancer elements can significantly influence the transcriptional activity of the TYK2 gene. These enhancers may be located kilobases away from the transcription start site and can be brought into proximity to the promoter through chromatin looping.[10]
- **Genetic Variants:** Single nucleotide polymorphisms (SNPs) within the TYK2 locus, including in non-coding regulatory regions, have been associated with altered TYK2 expression and susceptibility to autoimmune diseases.[11]

## Quantitative Data on TYK2 Gene Expression

The following tables summarize quantitative data on the regulation of TYK2 gene expression from various studies.

**Table 1: Regulation of TYK2 mRNA Expression by Cytokines**

Stimulus	Cell Type/System	Fold Change in TYK2 mRNA	Reference
IFN- $\alpha$	Psoriasis Patient PBMCs (PASI > 10)	Upregulated	
IL-12A	Psoriasis Patient PBMCs	Positive correlation with TYK2 expression	
IL-23A	Psoriasis Patient PBMCs	Positive correlation with TYK2 expression	

## Table 2: Effect of Genetic Variants (eQTLs) on TYK2 Gene Expression

SNP	Locus	Effect on TYK2 Expression	Tissue/Cell Type	Reference
rs892085	~400 kb upstream of TYK2	Alters TYK2 expression (inhibition and activation)	Jurkat T-lymphoblast cells	<a href="#">[12]</a> <a href="#">[13]</a>

## Experimental Protocols

This section provides detailed methodologies for key experiments used to study the transcriptional regulation of the TYK2 gene.

### Chromatin Immunoprecipitation Sequencing (ChIP-seq)

ChIP-seq is used to identify the genome-wide binding sites of a specific transcription factor.

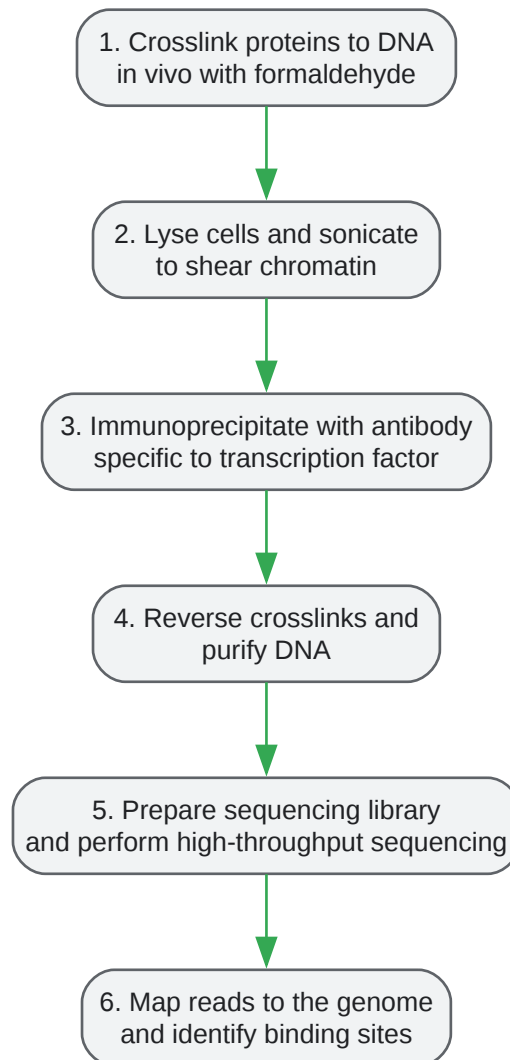

[Click to download full resolution via product page](#)

### Workflow for Chromatin Immunoprecipitation Sequencing (ChIP-seq).

#### Methodology:

- **Cross-linking:** Treat cells with 1% formaldehyde for 10 minutes at room temperature to cross-link proteins to DNA. Quench the reaction with glycine.
- **Cell Lysis and Chromatin Shearing:** Lyse the cells and sonicate the chromatin to obtain DNA fragments of 200-600 bp.
- **Immunoprecipitation:** Incubate the sheared chromatin with an antibody specific to the transcription factor of interest (e.g., STAT1, STAT3) overnight at 4°C. Add protein A/G

magnetic beads to pull down the antibody-protein-DNA complexes.

- Washes: Wash the beads extensively to remove non-specific binding.
- Elution and Reverse Cross-linking: Elute the complexes from the beads and reverse the cross-links by heating at 65°C. Treat with RNase A and Proteinase K to remove RNA and protein.
- DNA Purification: Purify the DNA using a column-based kit.
- Library Preparation and Sequencing: Prepare a sequencing library from the purified DNA and perform high-throughput sequencing.
- Data Analysis: Align the sequencing reads to the reference genome and use peak-calling algorithms to identify transcription factor binding sites.

## Luciferase Reporter Assay

This assay is used to measure the activity of a promoter or enhancer in response to specific stimuli or the overexpression of transcription factors.

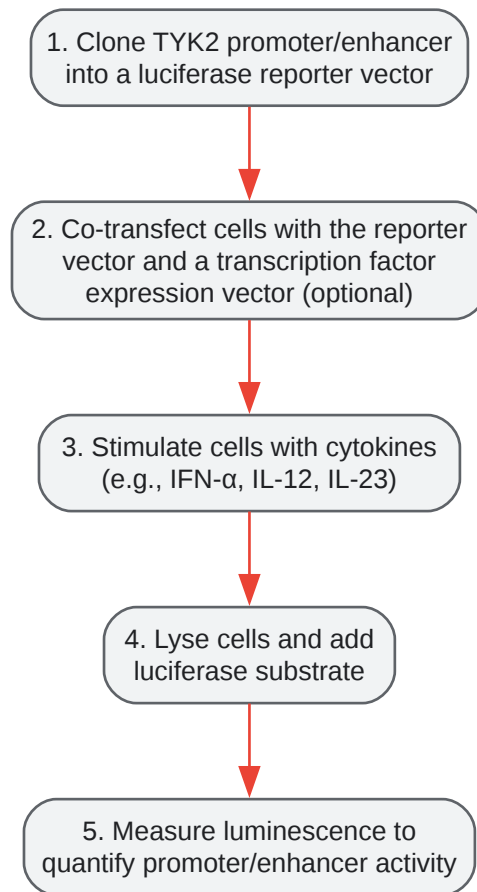

[Click to download full resolution via product page](#)

### Workflow for a Luciferase Reporter Assay.

#### Methodology:

- **Construct Preparation:** Clone the TYK2 promoter region of interest into a luciferase reporter plasmid (e.g., pGL3).
- **Cell Culture and Transfection:** Seed cells in a multi-well plate and transfect them with the reporter construct. A co-transfection with a Renilla luciferase plasmid can be used for normalization.
- **Stimulation:** After 24-48 hours, treat the cells with the desired stimulus (e.g., IFN- $\alpha$ , IL-12, or IL-23) for a specified time.
- **Cell Lysis:** Wash the cells with PBS and lyse them using a passive lysis buffer.

- **Luminescence Measurement:** Add the luciferase assay reagent to the cell lysate and measure the firefly luciferase activity using a luminometer. If using a dual-luciferase system, subsequently add the Stop & Glo reagent to quench the firefly signal and measure the Renilla luciferase activity.
- **Data Analysis:** Normalize the firefly luciferase activity to the Renilla luciferase activity to control for transfection efficiency.

## Quantitative Real-Time PCR (qPCR)

qPCR is used to quantify the amount of TYK2 mRNA in response to various stimuli.

Methodology:

- **RNA Extraction:** Isolate total RNA from cells using a suitable method (e.g., TRIzol or column-based kits).
- **cDNA Synthesis:** Reverse transcribe the RNA into cDNA using a reverse transcriptase enzyme and oligo(dT) or random primers.
- **qPCR Reaction:** Set up the qPCR reaction with the cDNA template, TYK2-specific primers, and a fluorescent dye (e.g., SYBR Green) or a probe-based system.
- **Thermocycling:** Perform the qPCR on a real-time PCR machine.
- **Data Analysis:** Determine the cycle threshold (Ct) values and calculate the relative expression of TYK2 mRNA using the  $\Delta\Delta C_t$  method, normalizing to a housekeeping gene (e.g., GAPDH, ACTB).

## Electrophoretic Mobility Shift Assay (EMSA)

EMSA is used to detect the in vitro interaction between a transcription factor and a specific DNA sequence.[\[14\]](#)[\[15\]](#)[\[16\]](#)[\[17\]](#)[\[18\]](#)

Methodology:

- **Probe Labeling:** Synthesize and label a short DNA probe corresponding to the putative transcription factor binding site in the TYK2 promoter with a radioactive isotope (e.g.,  $^{32}\text{P}$ ) or

a non-radioactive label (e.g., biotin).

- **Binding Reaction:** Incubate the labeled probe with nuclear extracts or a purified recombinant transcription factor in a binding buffer.
- **Electrophoresis:** Separate the protein-DNA complexes from the free probe on a non-denaturing polyacrylamide gel.
- **Detection:** Visualize the bands by autoradiography (for radioactive probes) or a chemiluminescent or colorimetric detection method (for non-radioactive probes). A "shifted" band indicates the formation of a protein-DNA complex.

## Site-Directed Mutagenesis

This technique is used to introduce specific mutations into the TYK2 promoter to study the functional importance of particular DNA sequences.[\[19\]](#)[\[20\]](#)[\[21\]](#)[\[22\]](#)[\[23\]](#)

Methodology:

- **Primer Design:** Design primers containing the desired mutation in the TYK2 promoter sequence cloned into a plasmid.
- **PCR Amplification:** Perform PCR using a high-fidelity DNA polymerase to amplify the entire plasmid containing the mutated sequence.
- **Template Digestion:** Digest the parental, non-mutated plasmid template with the DpnI restriction enzyme, which specifically cleaves methylated DNA (the parental plasmid is methylated, while the newly synthesized PCR product is not).
- **Transformation:** Transform the mutated plasmid into competent E. coli cells.
- **Verification:** Isolate the plasmid DNA from the resulting colonies and verify the presence of the desired mutation by DNA sequencing.

## Conclusion

The transcriptional regulation of the TYK2 gene is a complex process governed by a convergence of cytokine signaling pathways and the interplay of various transcription factors

and regulatory elements. A thorough understanding of these mechanisms is crucial for dissecting the role of TYK2 in health and disease and for the rational design of therapeutic interventions. The experimental protocols and data presented in this guide provide a solid foundation for researchers and drug development professionals to further investigate the intricacies of TYK2 gene regulation and to explore its potential as a therapeutic target. Future studies employing advanced techniques such as CRISPR-based genome editing and high-resolution chromatin conformation capture will undoubtedly provide deeper insights into the dynamic and cell-type-specific regulation of this pivotal immune signaling molecule.

### *Need Custom Synthesis?*

*BenchChem offers custom synthesis for rare earth carbides and specific isotopic labeling.*

*Email: [info@benchchem.com](mailto:info@benchchem.com) or [Request Quote Online](#).*

## References

- [1. en.wikipedia.org \[en.wikipedia.org\]](https://en.wikipedia.org)
- [2. TYK2 Tyrosine Kinase 2 Pathway \[immunologypathways.com\]](https://immunologypathways.com)
- [3. Gene - TYK2 \[maayanlab.cloud\]](https://maayanlab.cloud)
- [4. pmc.ncbi.nlm.nih.gov \[pmc.ncbi.nlm.nih.gov\]](https://pmc.ncbi.nlm.nih.gov)
- [5. pubmed.ncbi.nlm.nih.gov \[pubmed.ncbi.nlm.nih.gov\]](https://pubmed.ncbi.nlm.nih.gov)
- [6. nimbustx.com \[nimbustx.com\]](https://nimbustx.com)
- [7. BioKB - Relationship - TYK2 - activates - IL23 \[biokb.lcsb.uni.lu\]](https://biokb.lcsb.uni.lu)
- [8. pmc.ncbi.nlm.nih.gov \[pmc.ncbi.nlm.nih.gov\]](https://pmc.ncbi.nlm.nih.gov)
- [9. genecards.org \[genecards.org\]](https://genecards.org)
- [10. pubmed.ncbi.nlm.nih.gov \[pubmed.ncbi.nlm.nih.gov\]](https://pubmed.ncbi.nlm.nih.gov)
- [11. pmc.ncbi.nlm.nih.gov \[pmc.ncbi.nlm.nih.gov\]](https://pmc.ncbi.nlm.nih.gov)
- [12. academic.oup.com \[academic.oup.com\]](https://academic.oup.com)
- [13. researchgate.net \[researchgate.net\]](https://researchgate.net)
- [14. Electrophoresis Mobility Shift Assay \[bio-protocol.org\]](https://bio-protocol.org)
- [15. en.bio-protocol.org \[en.bio-protocol.org\]](https://en.bio-protocol.org)

- [16. Principle and Protocol of EMSA - Creative BioMart \[creativebiomart.net\]](#)
- [17. pmc.ncbi.nlm.nih.gov \[pmc.ncbi.nlm.nih.gov\]](#)
- [18. Transcription Factor mapping and prediction | CMB-UNITO \[cmb.i-learn.unito.it\]](#)
- [19. Site-Directed Mutagenesis \[protocols.io\]](#)
- [20. bpb-us-e2.wpmucdn.com \[bpb-us-e2.wpmucdn.com\]](#)
- [21. bioinnovatise.com \[bioinnovatise.com\]](#)
- [22. blog.addgene.org \[blog.addgene.org\]](#)
- [23. static.igem.org \[static.igem.org\]](#)
- To cite this document: BenchChem. [Transcriptional Regulation of the TYK2 Gene: An In-depth Technical Guide]. BenchChem, [2026]. [Online PDF]. Available at: [\[https://www.benchchem.com/product/b1180145/docs#transcriptional-regulation-of-the-tyk2-gene-an-in-depth-technical-guide\]](https://www.benchchem.com/product/b1180145/docs#transcriptional-regulation-of-the-tyk2-gene-an-in-depth-technical-guide)

---

**Disclaimer & Data Validity:**

The information provided in this document is for Research Use Only (RUO) and is strictly not intended for diagnostic or therapeutic procedures. While BenchChem strives to provide accurate protocols, we make no warranties, express or implied, regarding the fitness of this product for every specific experimental setup.

**Technical Support:** The protocols provided are for reference purposes. Unsure if this reagent suits your experiment?

**Need Industrial/Bulk Grade?** [Request Custom Synthesis Quote](#)

## BenchChem

Our mission is to be the trusted global source of essential and advanced chemicals, empowering scientists and researchers to drive progress in science and industry.

### Contact

Address: 3281 E Guasti Rd  
Ontario, CA 91761, United States  
Phone: (601) 213-4426  
Email: [info@benchchem.com](mailto:info@benchchem.com)

Contact our Ph.D. Support Team for a compatibility check